

These instructions explain how to adjust the Auto-Gun air jet using the orifice adjusting tool, Stock No. 16893.

1. Remove the nozzle nut, nozzle, and o-ring from the gun body.

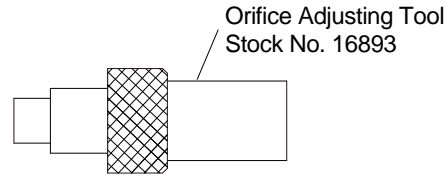

2. Loosen the jet lock nut and back-out the air set several turns.

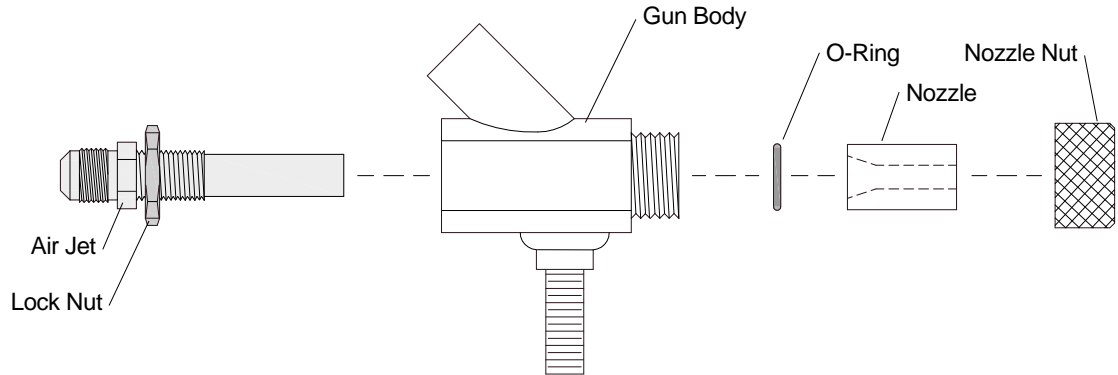

3. Screw the orifice adjusting tool into the gun until it seats against the gun body.

4. Turn the air jet to make sure the tool seats against the gun body and not the jet. If the jet does not turn freely by hand, back-out the jet several more turns and screw in the tool until it seats against the body.

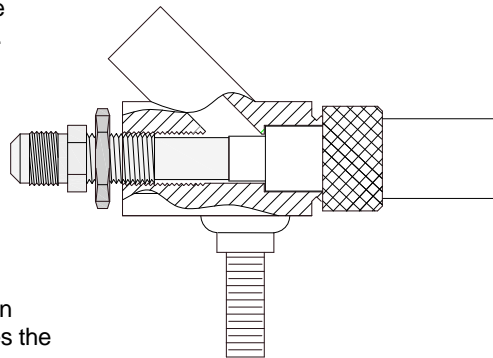

5. After the tool is seated against the gun body, screw the air jet in until it touches the adjusting tool.

6. Tighten the lock nut against the gun body to maintain the setting.

7. Remove the adjusting tool.

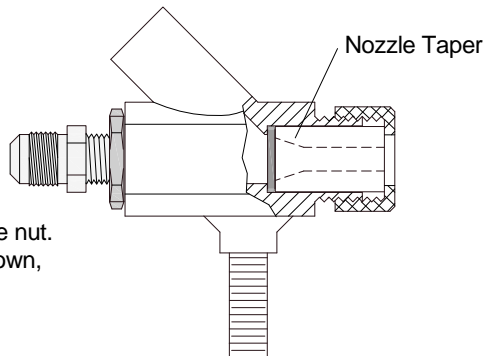

8. Replace the o-ring, nozzle, and nozzle nut. Make sure the nozzle is placed as shown, with the tapered end toward the jet.