

RPC-2 REVERSE PULSE DUST COLLECTOR



Clemco Industries Corp. • One Cable Car Drive • Washington, MO 63090
Phone: (636) 239-4300 • Fax: (800) 726-7559
Email: info@clemcoindustries.com

NOTICE TO PURCHASERS AND USERS OF OUR PRODUCTS AND THIS INFORMATIONAL MATERIAL

The products described in this material, and the information relating to those products, is intended for knowledgeable, experienced users of abrasive blasting equipment.

No representation is intended or made as to the suitability of the products described herein for any particular purpose of application. No representations are intended or made as to the efficiency, production rate, or the useful life of the products described herein. Any estimate regarding production rates or production finishes are the responsibility of the user and must be derived solely from the user's experience and expertise, and must not be based on information in this material.

The products described in this material may be combined by the user in a variety of ways for purposes determined solely by the user. No representations are intended or made as to the suitability or engineering balance of the combination of products determined by the user in his selection, nor as to the compliance with regulations or standard practice of such combinations of components or products.

It is the responsibility of the knowledgeable, experienced users of the products mentioned in this material to familiarize themselves with the appropriate laws, regulations and safe practices that apply to these products, equipment that is connected to these products, and materials that may be used with these products.

It is the responsibility of the user to insure that proper training of operators has been performed and a safe work environment is provided.

Our company is proud to provide a variety of products to the abrasive blasting industry, and we have confidence that the professionals in our industry will utilize their knowledge and expertise in the safe efficient use of these products.

OWNER'S MANUAL

1.0 INTRODUCTION

1.1 Scope of Manual

1.1.1 These instructions cover the assembly, installation, operation and maintenance of Clemco RPC-2 Reverse Pulse Dust Collectors.

1.1.2 These instructions also contain important information required for safe operation of the collector when used with a blast cabinet. Before using the cabinet all personnel involved with the cabinet operation must read this entire manual. Refer to the appropriate manual for operation of the blast cabinet.

1.2 Safety Alerts

1.2.1 Clemco uses safety alert signal words, based on ANSI Z535.4-1998, to alert the user of a potentially hazardous situation that may be encountered while operating this equipment. ANSI's definitions of the signal words are as follows:

 This is the safety alert symbol. It is used to alert the user of this equipment of potential personal injury hazards. Obey all safety messages that follow this symbol to avoid possible injury or death.

CAUTION

Caution used without the safety alert symbol indicates a potentially hazardous situation which, if not avoided, may result in property damage.

 **CAUTION**

Caution indicates a potentially hazardous situation which, if not avoided, may result in minor or moderate injury.

 **WARNING**

Warning indicates a potentially hazardous situation which, if not avoided, could result in death or serious injury.

 **DANGER**

Danger indicates an imminently hazardous situation which, if not avoided, will result in death or serious injury.

1.3 General Description

1.3.1 RPC-2 Dust Collectors are dry, reverse pulse jet cartridge collectors, used to ventilate abrasive blast cabinets and remove dust from exhausting air. Figure 1 show typical arrangements and call-outs used in the manual. Silencer may face up or down as shown.

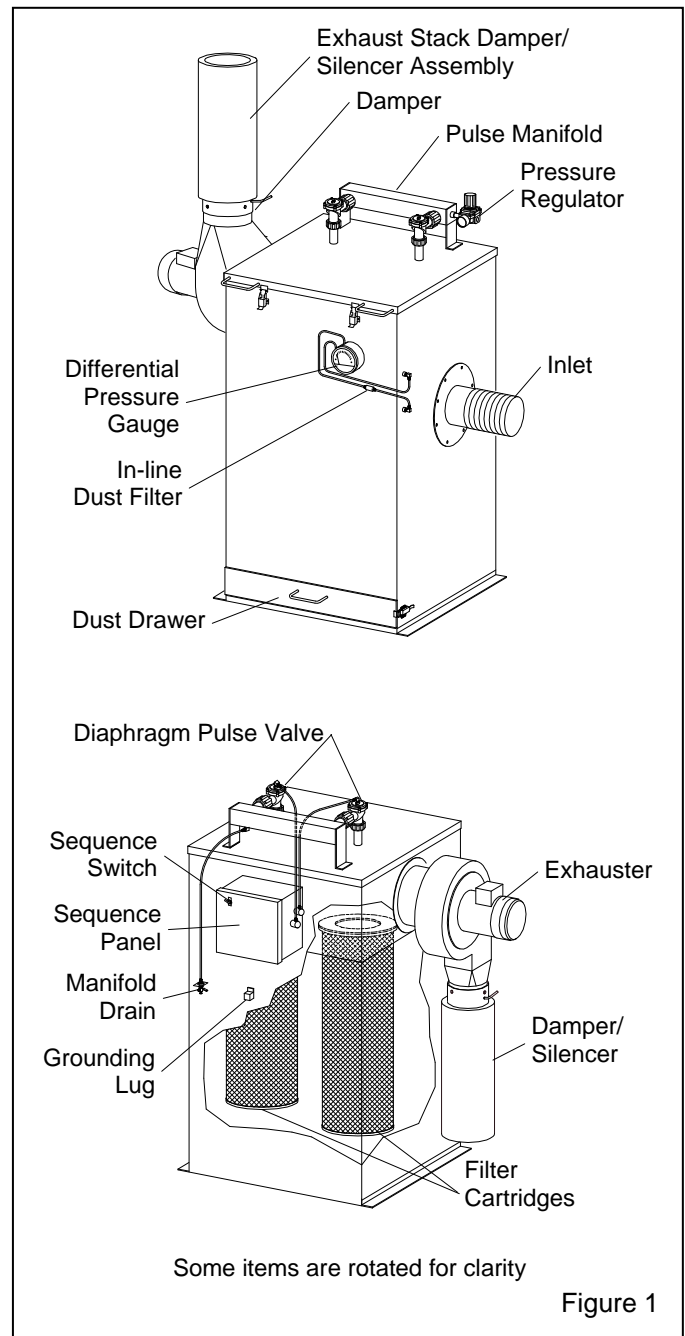

Figure 1

1.3.2 The exhauster is mounted on the clean-air side of the filter cartridges, and provides "pull-through" (pulls air through the reclaimers) air flow, rated at 600, or 900 cfm, depending on the exhauster size. Dust and fines are drawn through the reclaimers into the dust collector, trapping dust before discharging clean air.

1.3.3 Filter cartridges are cleaned by a pulse of high velocity compressed air expanding against the inner surface of the cartridges. The expanding air momentarily reverses air flow through the cartridge, releasing dust that has accumulated on the outer surface. The dust particles fall away from the cartridges and into the dust drawer for removal.

1.3.4 The pulse interval is controlled by a timer located inside the sequence panel. The timer controls the ON time (the length of time for each pulse) and OFF time (the length of time between each pulse). The ON time should never be adjusted. The lower the setting for the OFF time, the shorter the length of time between pulses.

CAUTION

Do not pulse new dust collectors or replacement cartridges until the cartridges are properly seasoned. See Section 6.2. Pulsing unseasoned cartridges could cause premature cartridge failure or decrease the efficiency of dust collector.

1.3.5 A toggle switch (sequence switch) located on the sequence panel cover, enables or disables the timing sequence. The user has an option to connect the exhauster and sequence panel to the cabinet controls. If the sequence panel is wired into the exhauster controls, and the sequence switch is kept ON, the timing sequence energizes when the exhauster is turned on, automatically pulsing the cartridges when the exhauster is running. If the switch is OFF, the timer will not energize, and the cartridges will not be pulsed.

1.3.6 The differential pressure gauge shows the pressure difference between the dust side and clean side of the cartridges. The gauge helps determine the proper pulse pressure and timer OFF time setting. See Sections 4.1 and 4.2

2.0 SET-UP AND INSTALLATION

2.1 Push-Through Reclaimer Conversions, (exhauster mounted on reclaimer), Figure 2

NOTE: If the dust collector replaces an existing filter bag or dry filter, the reclaimers must be converted to a "pull-through" style. If a conversion is required, an externally adjustable vortex cylinder and gasket must be ordered (stock numbers shown in Figure 2) to replace the existing exhauster. If the reclaimer is already a "pull-through" style, skip to Section 2.2.

WARNING

Lock out and tag out the electrical supply before performing any electrical service. Shorting electrical components could result in death, serious electrical shocks, or equipment damage. All electrical work, or any work done inside an electrical panel, must be performed by qualified electricians, and comply with applicable codes.

2.1.1 Lock-out and tag-out power to the cabinet control box and reclaimers motor.

2.1.2 Remove the cap screws securing the motor plate to the exhauster. Lift up on the motor to remove the motor, motor plate and paddle wheel assembly.

2.1.3 Remove the cap screws located inside the exhauster housing (save for reuse), and remove the housing from the top of the reclaimer.

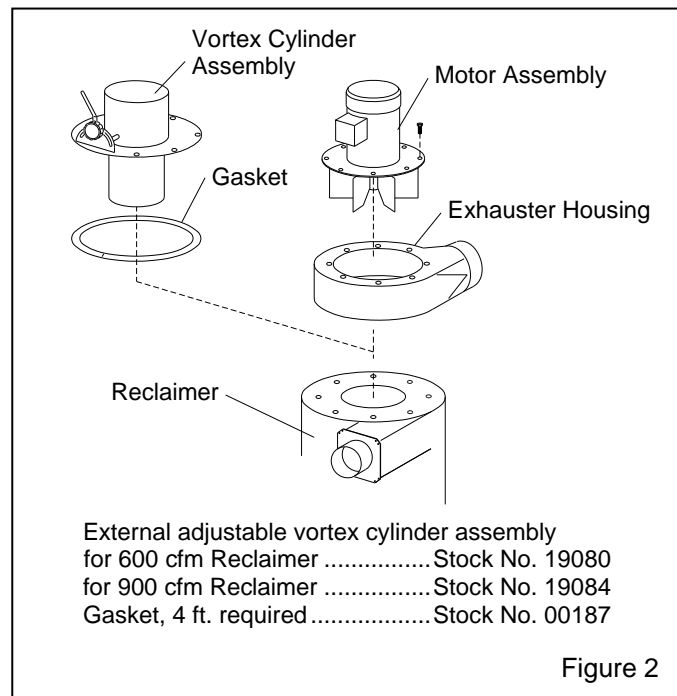

2.1.4 Remove the backing from the gasket and place the gasket along the inside perimeter of the reclaimers bolt holes. Use cap screws to attach the vortex to the reclaimers.

2.2 Set-Up

2.2.1 Position the collector in a convenient location that complies with OSHA and local safety codes. Allow access to the differential pressure gauge and exhaust damper. Provide ample space at the top to open the cover to access the cartridges, and in the front to remove the dust drawer without tipping it.

2.2.2 Use the four cap screws provided, to attach the exhauster stack damper assembly to the exhauster outlet as, shown in Figure 3. NOTE: The silencer may face up or down as shown in Figure 1.

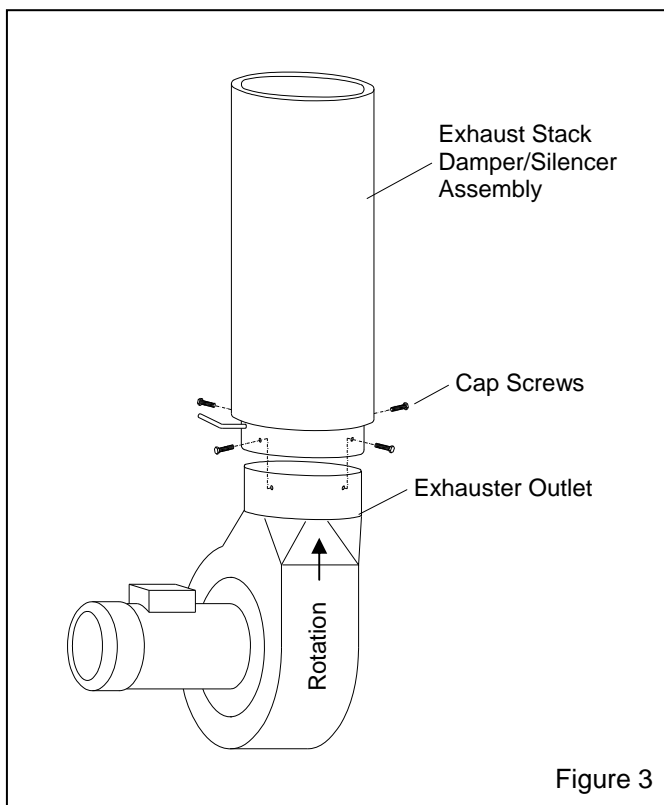

Figure 3

2.3 Connect Electrical Power

⚠ WARNING

Shorting electrical components could result in serious electrical shocks, or equipment damage. All electrical work must be performed by a qualified electrician, and comply with applicable codes.

NOTE: A wiring schematic for the RPC Collector is packed in the sequence panel. A schematic for Clemco cabinets is supplied with the cabinet. After wiring is completed, keep the schematics and manuals together for future reference and electrical replacement parts.

Wiring from the user's disconnect to the cabinet controls must be provided by the user. Conduit and wiring from the control box (or starter) to the exhauster motor and 115 volts to the RPC Control Panel (Pulse Sequence Panel), must also be provided by the user.

If the RPC Collector replaces an existing "push through" collector or dust bag, the exhauster may be wired into the control box, to the terminal strip or starter where the conduit from the old reclaimers motor is attached.

2.3.1 Electrical requirements depend on the size and phase of the motor. Standard dust collectors are supplied as follows:

600 CFM collectors, 1 HP, 115/230 V., 1 PH, 60 HZ
900 CFM collectors, 2 HP, 230/460 V., 3 PH, 60 HZ

⚠ WARNING

Electrical power must be locked out and tagged out before continuing. Failure to do so could result in death or serious injury from electrical shock.

2.3.2 Install conduit, and wire the exhauster motor per instruction on the motor plate, and the motor starter (for 3 PH wiring), or terminal strip (for 1 PH wiring) as shown on the schematic.

2.3.3 Install conduit, and wire 115 volt power to the reverse pulse control panel as shown on the schematic.

2.3.4 After the wiring is completed, observe the subsequent warning, and check the motor rotation. To check rotation, jog the starter (momentarily turn switch on and off). This will cause the motor to rotate slowly. Look through the slots in the fan housing on top of the motor where rotation of the fan can easily be observed. Proper rotation is indicated by the arrow on the exhauster housing. The fan should rotate toward the exhauster outlet as shown in Figure 3.

⚠ WARNING

Do not look into the exhauster outlet while the paddle wheel is turning. Injury to the eye or face could occur from objects being ejected from the exhauster.

2.3.5 Check the amperage on initial start up. If the motor draws excessive amperage, gradually close the damper until the amperage is within the specifications shown on the motor plate. The damper is located on the exhaust outlet.

2.4 Flex Hose Connection

2.4.1 Connect the flexible exhaust hose between the reclaim outlet adaptor and dust collector inlet adaptor. It may be easier to slip the hose over the adaptors, and create a tighter seal, if the first two or three inches of wire is removed from the inside of the hose. Use care not to damage the hose. Secure the hose with worm clamps. NOTE: The hose wire helps dissipate static in the conveying hose, and helps ground each segment. In order for the hose wire to dissipate static electricity, the wire must touch the metal of each segment.

2.5 Ground Cabinet

2.5.1 To prevent static electricity build up, attach an external grounded wire from an earth ground to the grounding lug located on the rear wall of the collector.

2.6 Compressed Air Connections

NOTE: For maximum filter life and efficiency, the pulse air source should be 30% relative humidity or less, and be free of any oil contaminants. If line air does not meet this requirement, an air dryer is recommended.

2.6.1 Connect a 1/2" or larger air hose to the pressure regulator located on the pulse manifold inlet. An isolation valve should be installed at the air source to enable depressurization for service. If rigid pipe is used for the air line, a flexible section of hose must be used at the connection, to enable the top access door to swing open for service.

WARNING

If twist-on type air hose couplings are used, they must be secured by safety pins or wires to prevent accidental disconnection while under pressure. Hose disconnection while under pressure could cause serious injury.

2.7 Install Manometer, Refer to Section 4.4

3.0 OPERATION

WARNING

All persons operating this equipment must be made aware of the hazards of abrasive blasting. Prolonged exposure to any dust could result in serious lung disease and death. Short term ingestion of toxic materials, such as lead dust or dust from other heavy metals and corrosives, could cause serious respiratory injury or death. Identify all materials that are to be removed by blasting, and obtain a Materials Safety Data Sheet (MSDS) for the blast media. If lead coating or other toxic materials are being removed by the blasting process, HEPA after-filters must be used for those applications.

3.1 Initial Start-up

3.1.1 The dust collector access doors and dust drawer must be closed when the dust collector is on.

CAUTION

Do not pulse new dust collectors or replacement cartridges until the cartridges are properly seasoned. Refer to Section 6.2. Pulsing unseasoned cartridges could cause premature cartridge failure or decrease the efficiency of dust collector.

3.1.2 With the sequence switch OFF, open the compressed air supply valve to pressurize the pulse manifold. Check the air line and connections for leaks.

3.1.3 Using the regulator on the manifold inlet, turn pulse pressure to 20 psi. Turn the sequence switch ON, and check the air pulse and sequence of the diaphragm valves, solenoids, and panel timer. After the operation of the pulse system is confirmed, turn the sequence switch OFF and increase pressure to 70 psi.

3.1.4 Do not turn the sequence switch ON until the cartridges are seasoned per Section 6.2.

3.2 Operation Start-Up

3.2.1 Make sure the top access door is secured with clamps, and that the dust drawer is closed.

3.2.2 Make sure the sequence switch is on. NOTE: Do not turn the sequence switch ON until the cartridges are properly seasoned, per Section 6.2.

3.2.3 Start the exhauster at the control panel, usually mounted on the blast cabinet.

3.2.4 Check the pulse manifold pressure.

3.3 Shutdown

3.3.1 Run the collector until all media is recovered from the cabinet, and the cabinet is free of airborne dust.

3.3.2 Turn off the exhauster.

3.3.3 Turn off the compressed air supply valve.

3.3.4 Drain the pulse manifold whenever the compressed air supply is turned off. The drain petcock is mounted on the side of the collector. See Figure 1.

3.3.5 Empty contents of the dust drawer into a suitable container, per Section 5.1.

4.0 Adjustments

4.1 Pulse Manifold Pressure

4.1.1 The pressure regulator located on the pulse manifold inlet, adjust pulse pressure. Set initial pressure at 70 psi. Refer to Section 4.2.4.

4.1.2 Do not increase pulse pressure until the pulse sequence is at maximum intervals as describe in Section 4.2.

4.2 Pulse Sequence Control Panel and Timer

4.2.1 The toggle switch (sequence switch) mounted on the sequence control panel cover, enables or disables the timing sequence. When the switch is ON, the pulse sequence automatically starts when the dust collector exhauster is started. If the switch is OFF the pulse sequence will not occur. The switch should be left OFF (no pulse) until cartridges are seasoned. See Section 6.2.

4.2.2 The timer is factory set at 40 seconds OFF and 15/100 of a second ON. Every 40 seconds the cartridges are pulsed.

4.2.3 As the cartridges cake with dust, the pulse may not clean them well enough to bring the differential pressure gauge below the recommended changeover pressure of 4". A constant reading higher than 4" is an indication that more frequent pulse cycles or higher pressure are needed. When the differential pressure gauge shows a constant pressure difference greater than 4", adjust the OFF time setting by half. DO NOT ADJUST

ON TIME. Increasing on time will consume more air, but will NOT increase cleaning efficiency.

4.2.4 When the frequency of the pulse cycles will not lower the differential pressure to less than 4", or if a decrease in the efficiency is noted, increase pulse pressure in increments of 10 psi until the maximum of 100 psi is reached.

4.2.5 When the frequency of the pulse cycles and higher pulse pressure will not lower the differential pressure below the changeover pressure of 4" w. c., the filter cartridges should be replaced, and the timer OFF time should be reset to 40 seconds, and pressure set to 70 psi. See Section 6.1.

4.3 Damper Setting (Static Pressure)

4.3.1 Static pressure must be adjusted for optimum reclaimer efficiency. Correct static pressure varies with size of reclaimer and the size, weight and type of media.

4.3.2 Adjust static pressure using the damper located on the dust collector exhauster outlet at the base of the silencer, and the manometer provided with the dust collector.

4.3.3 Adjust static pressure by further opening the damper (handle toward vertical) to increase static pressure or further closing the damper (handle toward horizontal) to decrease static pressure. Open only as far as necessary to obtain a balance of dust removal without media carryover.

4.3.4 If the static pressure is too low, the results will be dirty media. Dirty media consists of good media, dust, fines, and blasting by-products.

4.3.5 If the static pressure is too high, it may cause carryover (usable media carried into the dust collector) and result in excessive media consumption.

4.3.6 Use the manometer, and adjust the damper to obtain the pressure in inches of water, as specified below. The measurements are starting points only. With light-weight, or finer media the setting may need to be lower; with heavier and coarse media the setting may need to be higher.

Media	Size	Static Pressure
Glass Bead	5 to 7	3-1/2 to 4 inches
Glass Bead	8 to 13	3 to 3-1/2 inches
Al. Oxide	60 and coarser	4 to 5 inches
Al. Oxide	80 and finer	3 to 4 inches
Plastic	All *	2-1/2 to 3 inches
Steel Grit	**	6 to 7 inches

* Non-Aerolyte reclaimers require modification. Consult the factory.

** Size is limited, and determined by the system's application.

4.3.7 Fine-tuning is required for optimum reclaimer efficiency. After adjusting the damper to the best balance of media recovery and media cleaning, carry-over, or dirty media continues to be a problem, the adjustable vortex cylinder may need adjustment. Consult the cabinet manual or reclaimer manual for vortex adjustment.

4.4 Manometer

NOTE: These instructions show several methods of taking static pressure readings (negative pressure) on cabinet reclaimers, using a flexible tube manometer. Use the method best suited for the application. The instructions explain the processes for taking periodic readings and how to permanently install the manometer for taking frequent readings. Permanent fittings should be installed when rigid ducting is used, or when the manometer installation is permanent. Use silicone sealer or other sealant to seal around the fitting to prevent leaks. The fitting should be capable of being capped when the manometer tube is removed. This will prevent leaks that alter the reclaimer's separation efficiency. Taking readings at different locations could produce different readings. Static pressure readings at the door are generally .5" to 1" lower than those taken above the reclaimer. The readings are reference points, so readings should be taken using the same method each time the reading is taken.

4.4.1 Refer to directions packed with the manometer for preparation and operating instructions for the manometer.

4.4.2 Connect one end of the 3/16" ID tubing to one of the tubing connectors (elbow) at the top of the manometer, by pushing it over the barbed adaptor.

4.4.4 Leaving the needle protector on the needle, insert the needle into the other end of the tubing. The ends of the tubing must fit tight on the manometer and needle; leaks will give inaccurate readings.

⚠ WARNING

Do not remove the needle shield during the assembly. The needle is difficult to fit into the tubing, and the shield protects the installer from needle punctures.

4.4.5 Open both manometer valves (elbow fittings). Both valves must be open to obtain a reading. Refer to the supplement manual supplied with the manometer for operation.

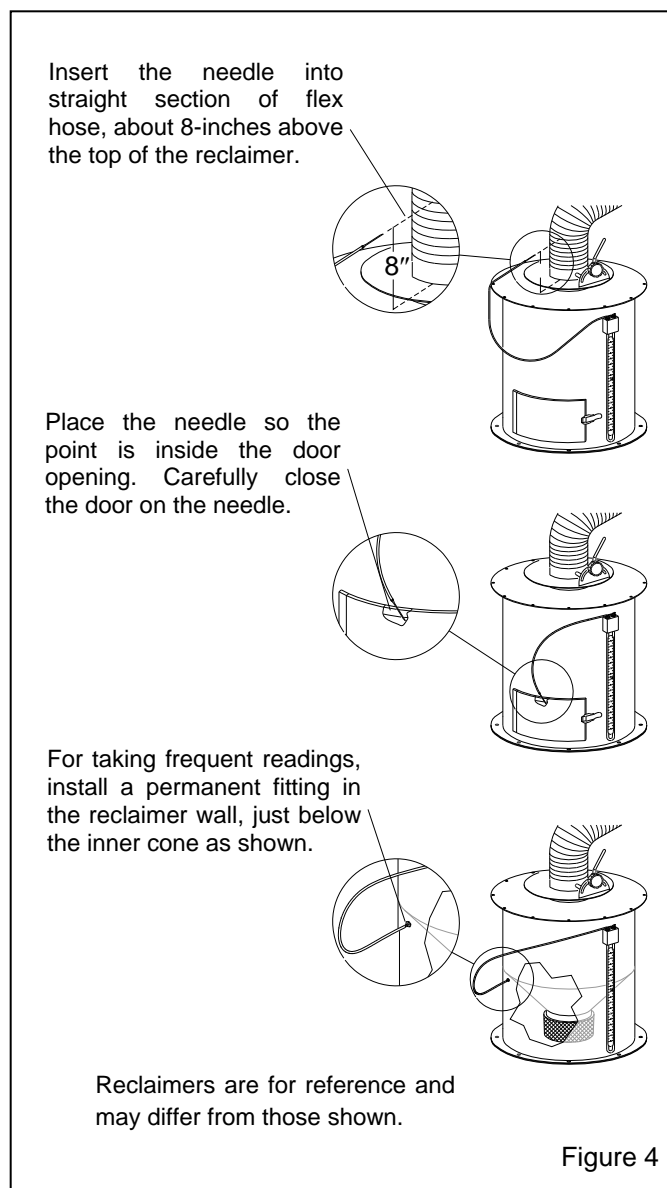

4.4.6 Place the manometer on the side of the reclaimer; magnets on the manometer hold it in position. The manometer must be vertically-plumb so the fluid is level on both sides of the tube.

4.4.7 Needle placement: Ref. Figure 4.

4.4.7.1 Remove the needle protector, and place the needle using one of the methods shown in Figure 4.

4.4.8 Turn ON the exhauster. The negative (static) pressure will move fluid in the tube.

NOTE: Readings must be taken with the cabinet doors open, and with the exhauster running.

4.4.9 To find the static pressure, add the number of inches the fluid travels up column one column to the

inches the fluid travels down the other column. Refer to the example in Figure 5.

4.4.10 After the readings are taken, replace the needle protector. Close the manometer valves and store the manometer in the original container in a clean area. Note: If the manometer installation is permanent, the manometer may remain on the reclaiming body after the valves are closed.

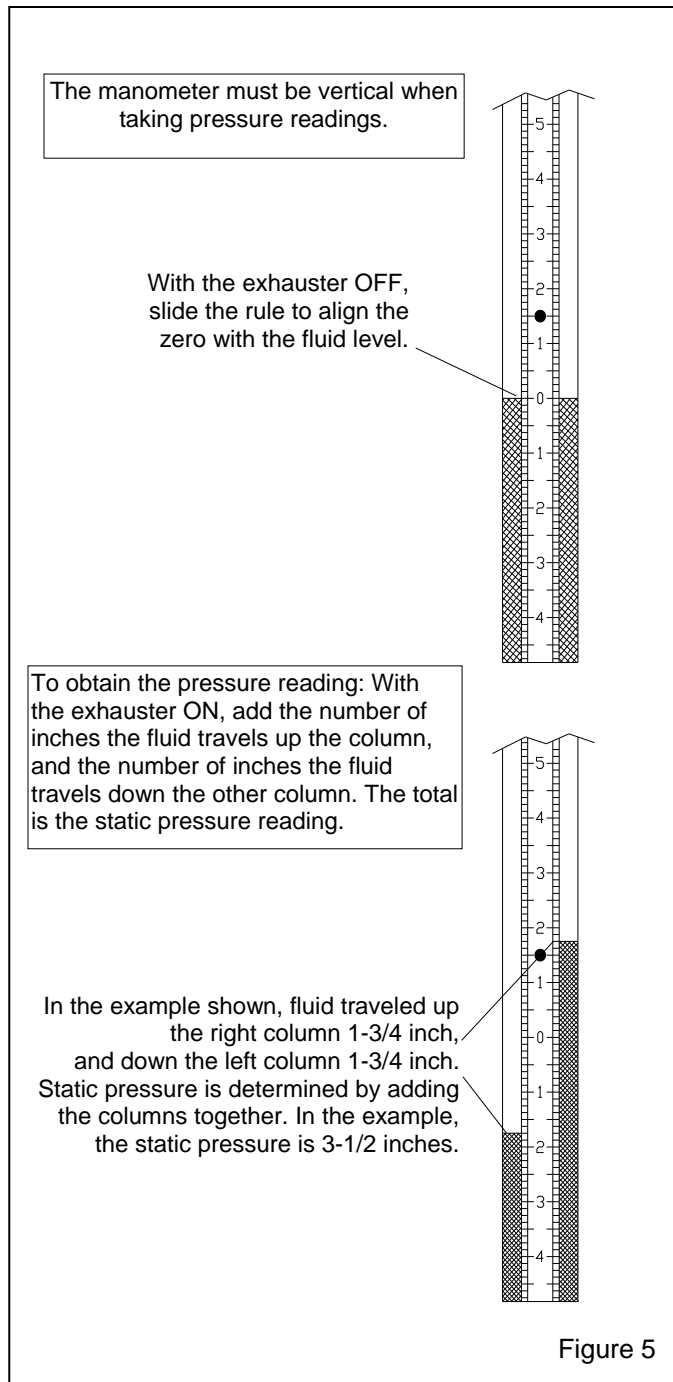

5.0 PREVENTIVE MAINTENANCE

⚠ WARNING

Always wear a properly fitted and maintained, NIOSH approved respirator and eye protection when emptying the dust drawer. Failure to do so could result in respiratory disease or serious respiratory and eye irritation. Toxicity and health risk vary with type of media, and dust generated by blasting. Identify all material that is being removed by blasting, and obtain a Materials Safety Data Sheet for the blast media.

5.1 Daily

5.1.1 With the exhauster turned off, empty the dust drawer. Heavily contaminated parts or friable media may require the drawer be emptied more often. Never allow the drawer to become more than a quarter full.

5.1.2 Check the exhaust air during a pulse cycle. If dust is emitting from the exhauster, cartridges are leaking or damaged. Check immediately.

5.1.3 With the exhauster turned on, check the differential pressure gauge. If reading is high (greater than 4" above initial reading), adjust pulse pressure and/or sequence per Section 4.1 and 4.2.

5.2 Weekly

5.2.1 With the exhauster turned off, check the in-line dust filter dust accumulation. The filter is located on the side of the collector. See Figure 6.

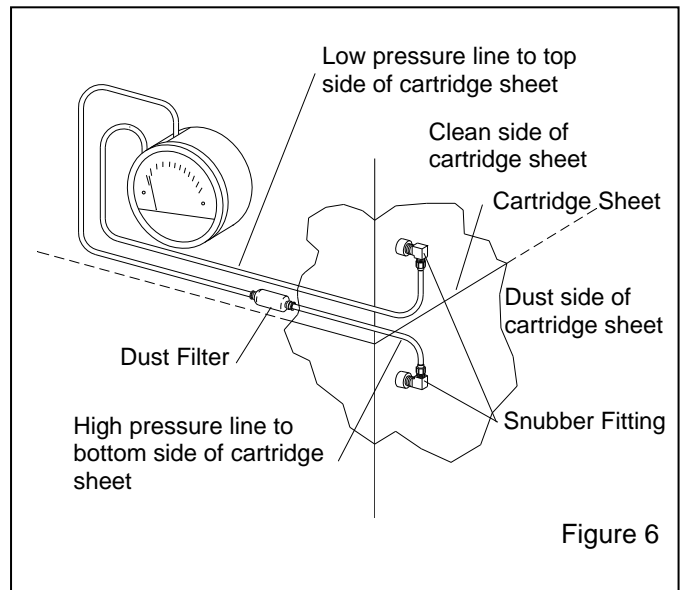

6.0 SERVICE MAINTENANCE

WARNING

All maintenance must be done with the electrical power locked-out and tagged-out, and the compressed air supply line bled, locked-out and tagged-out. Failure to do so could result in death or serious injury from electrical shock, unintentional actuation of a component, or from the venting of trapped compressed air.

6.1 Replacing Filter Cartridges

WARNING

Failure to wear properly fitted and maintained, NIOSH approved respirator and eye protection when servicing dust laden areas of the dust collector could result in serious eye irritation and lung disease or death. Toxicity and health risk vary with type of media, and dust generated by blasting. Identify all material that is being removed by blasting, and obtain a Materials Safety Data Sheet for the blast media.

6.1.1 Empty the dust drawer, and return the drawer to its position.

6.1.2 Open the top access door.

6.1.3 Remove the nuts securing the cartridge hold-down plates.

6.1.4 Remove the hold-down plates and venturi tubes.

6.1.5 Remove cartridges from the top. A small amount of force may be necessary to loosen the seal of the cartridge gasket.

6.1.6 When cartridges are removed, clean the inside of the collector to remove loose or hardened dust, particularly from the cartridge sealing surface, and the clean side (top side) of the cartridge sheet.

6.1.7 Install new cartridges; center each cartridge, install venturi tube, and secure with hold-down plates.

6.1.8 Inspect the access door gasket, replace if worn or damaged. Close the access door and secure.

6.1.9 Reset timer OFF time to 40 seconds.

6.1.10 Reset pressure to 70 psi.

6.1.11 Season cartridges per Section 6.2.

6.2 Seasoning Cartridges

6.2.1 New cartridges must be seasoned. Cartridges are seasoned by letting a dust layer develop on the outside surface of the filter media. The dust layer protects the filter cartridge, and enhances the filtering efficiency.

6.2.2 Operate the collector without pulsing (sequence switch off) until the differential pressure gauge reads four inches (4" w. c.).

6.2.3 After the differential pressure is reached, set the timer OFF time to 40 seconds, and set the pulse pressure at 70 psi.

6.2.4 Turn the sequence switch ON to start the pulse cycle. See Section 4.2.

7.0 TROUBLESHOOTING

WARNING

Shut down the collector immediately if dust is emitting from the exhauster. Check to make sure that cartridges are correctly seated and not worn or damaged. Prolonged breathing of abrasive dust and blasting by-product dust could result in serious lung disease or death. Short term ingestion of toxic dust such as red lead, poses an immediate danger to health. Identify all materials that are to be removed by blasting, and obtain a Materials Safety Data Sheet for the blast media.

7.1 Collector Not Pulsing

7.1.1 Check the manifold pressure gauge. If the reading is low, check the regulator adjustment, and compressed air supply, look for a closed supply valve.

7.1.2 Check to make sure the sequence switch is not turned off.

7.1.3 Check the fuse in the sequence control panel. Replace as necessary.

7.2 One Cartridge Not Pulsing

7.2.1 Solenoid defective. Check continuity for electrical malfunction.

7.2.2 Check the diaphragm valve. With the compressed air turned off, remove the four cover screws, inspect the diaphragm and clean the bleed port.

7.2.3 Check for blockage in the tubing to the diaphragm valves.

7.3 Pulse is a steady stream of air instead of a pulse.

7.3.1 Check for a leak in the tubing between the diaphragm valves and solenoid.

7.3.2 Solenoid remaining in open position. Check continuity, clean, replace.

7.4 Exhauster Not Running

7.4.1 Exhauster overload could be tripped. Reset and check for overload.

7.4.2 Make sure that the main disconnect is "on".

7.4.3 Motor defective. Check continuity.

7.5 Excessive Differential Pressure

7.5.1 Valves may not be pulsing properly. See 7.1.

7.5.2 The differential pressure gauge lines may be plugged with dust. Check and clean.

7.5.3 Make sure the tubing has not been inserted so far into the tube connection that it blocks the tube ends.

7.5.4 The in-line dust filter may be blocked. Clean or replace.

7.5.5 Snubber fittings blocked with dust. Clean or replace. Refer to Figure 6..

7.5.6 The sequence OFF time may need adjusting. See Section 4.2.

7.5.7 Filter cartridges may need to be replaced. See Section 4.2 and 6.1.

7.6 No Reading On Differential Pressure Gauge.

7.6.1 Check to make sure the low and high pressure lines have not been reversed. Refer to Figure 6.

7.7 Dust Emitting From Exhauster.

7.7.1 Check for loose or damaged filter cartridge.

8.0 REPLACEMENT PARTS

8.1 Accessories

Description	Stock No.
(-) Vortex cylinder assembly, to convert push-through reclaimer to a pull-through for 600 cfm Reclaimer	19080
for 900 cfm Reclaimer	19084
(-) Manometer kit	12528

8.2 Sequence Panel, not shown

Item	Description	Stock No
(-)	Sequence control panel assembly.....	15788
(-)	Sequence control board	10261
(-)	Solenoid.....	10262
(-)	Switch, toggle	12127
(-)	Boot, toggle switch.....	14228

8.3 Collector Assembly, Figure 7

Item	Description	Stock No.
(-)	RPC-2 Collector assembly	
	600 cfm w/ 1 hp, 115v motor.....	15804
	600 cfm w/ 1 hp, 230v motor.....	15939
	900 cfm w/ 2 hp, 230v motor.....	20526
1.	Filter cartridge, 13" x 36"	15781
2.	Venturi tube	15674
3.	Plate, hold-down	16213
4.	Valve, 1.5" diaphragm	15818
(-)	Repair kit for 1-1/2" pulse valve (above) ...	21601
5.	Gasket, 5/16" x 1" adhesive backed, specify feet required	00187
6.	Latch	10290
7.	Fitting, 1/4" NPT bulkhead	05605
8.	Petcock, 1/4" NPT	01993

9.	Gauge, pressure	11826
10.	Gauge, differential pressure	10188
11.	Snubber fitting	15786
12.	Ground lug	11639
13.	Tubing, 1/4" nylon, specify feet required ...	15892
14.	Adaptor, elbow, 1/8" NPT x 1/4" tube	15787
15.	Adaptor, elbow, 1/4" NPT x 1/4" tube	03428
16.	Adaptor, straight, 1/4" NPT x 1/4" tube	03429
17.	Adaptor, straight, 1/8" NPT x 1/4" tube	03430
18.	Regulator, 1/2" NPT pressure, w/ gauge ...	01902
19.	Filter, in-line dust	23415
20.	Inlet adaptor	
	600 cfm, 6"	16362
	900 cfm, 7"	16837
21.	Clamp, hose	11576
22.	Hose, flex, specify feet required	
	6" for 600 cfm	12452
	7" for 900 cfm	12448

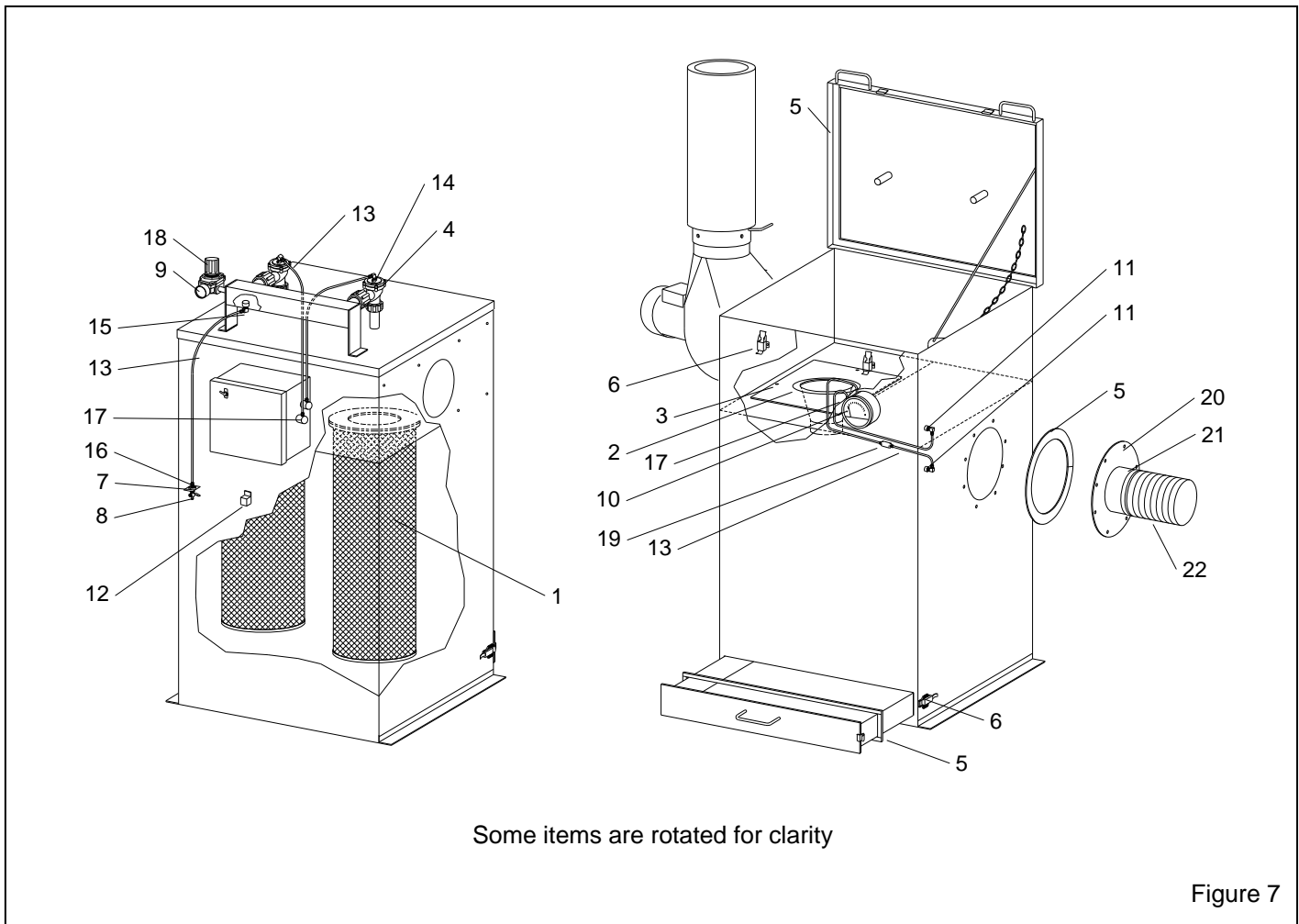

8.4 Exhauster Assembly, Figure 8

Item	Description	Stock No
1.	Motor	
	600 cfm, 1 Hp, 115-V, 1 Ph, standard..	12314
	600 cfm, 1 Hp, 230-V, 3 Ph	12310
	900 cfm, 2 Hp, 230-V, 3 ph, standard..	12309
	900 cfm, 2 Hp, 230-V, 1 Ph	02979
2.	Plate, motor mount	
	600 cfm	12004
	900 cfm	12005
3.	Housing, exhauster	
	600 cfm	12272
	900 cfm	12271
4.	Gasket, 5/16" x 1" adhesive-backed,	
	specify feet required	00187
5.	Paddle wheel	
	600 cfm	12334
	900 cfm	12335
6.	Adaptor, exhauster	
	600 cfm	16836
	900 cfm	16835
7.	Damper assembly, less sound foam	
	600 cfm, 6"	19382
	900 cfm, 7"	18414
8.	Sound foam, 4 sq. ft. req'd., trim to fit	12484

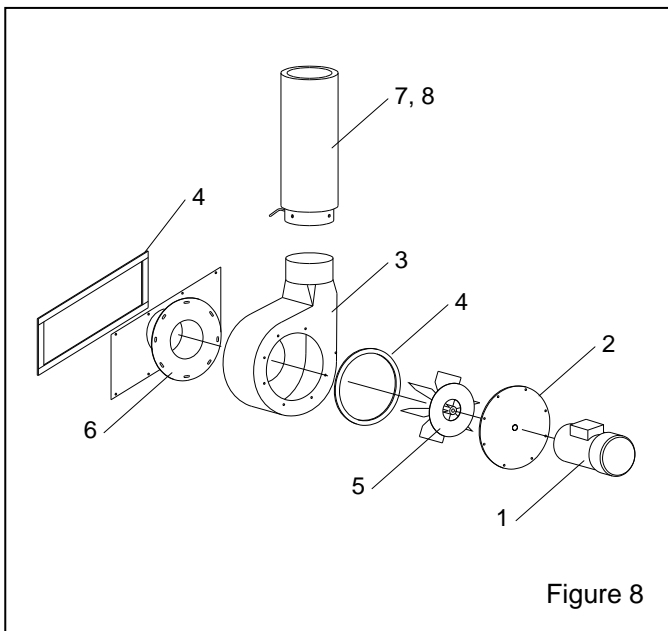

Figure 8