

# QUANTUM ABRASIVE METERING VALVES

O. M. 22565

DATE OF ISSUE: 01/00

REVISION: G, 3/24

© 2024 CLEMCO INDUSTRIES CORP.

One Cable Car Dr.

Washington, MO 63090

Phone (636) 239-4300

Fax (800) 726-7559

Email: [info@clemcoindustries.com](mailto:info@clemcoindustries.com)

[www.clemcoindustries.com](http://www.clemcoindustries.com)



## **WARNING**

**Do not use this equipment until you have READ this MANUAL and YOU UNDERSTAND its contents.\***

**These WARNINGS are included for the health and safety of the operator and those in the immediate vicinity.**

\*If you are using a Clemco Distributor Maintenance and Parts Guide, refer to the orange warnings insert preceding the Index before continuing with the enclosed instructions.

Electronic files include a Preface containing important information.

# QUANTUM ABRASIVE METERING VALVES

## 1.0 INTRODUCTION

### 1.1 Scope of manual

**1.1.1** These instructions cover the installation, operation, maintenance, troubleshooting, and replacement parts for Clemco's three models of the Quantum abrasive metering valve shown below.

- Manual Quantum Pro abrasive metering valve (MQV PRO)
- Auto-Quantum (AQV) is the standard Auto-Quantum and is used in most applications requiring a pneumatically operated metering valve. It requires approximately 80 psi to fully open.
- Auto-Quantum-H (AQV-H) is generally used in pressure-hold applications using coarse abrasives. It closes with higher spring pressure and requires approximately 90 psi to fully open. The most noticeable internal difference is the use of a urethane wear sleeve and a plunger stamped with an "H" on the end. It is identified on the outside by an "H" stamped on the actuator body.

**1.1.2** This manual contains important safety information. All operators and personnel involved with the abrasive blast process must read and understand the contents of these instructions, including the orange cover. It is equally important that the operator is trained and qualified to safely operate the blast machine and remote controls and all other equipment used with the blast machine.

**1.1.3** All personnel involved with the abrasive blasting process must be made aware of the hazards associated with abrasive blasting. The Clemco booklet "Abrasive Blasting Safety Practices" is included with every blast machine; it contains important safety information about abrasive blasting that may not be included in equipment operation manuals. To request additional copies, email [info@clemcoindustries.com](mailto:info@clemcoindustries.com).

### 1.2 Safety Alerts

**1.2.1** Clemco uses safety alert signal words, based on ANSI Z535.4-2011, to alert the user of a potentially hazardous situation that may be encountered while operating this equipment. ANSI's definitions of the signal words are as follows:



**This is the safety alert symbol. It is used to alert you to potential physical injury hazards. Obey all safety messages that follow this symbol to avoid possible injury or death.**

## NOTICE

Notice indicates information that is considered important, but not hazard-related, if not avoided, could result in property damage.

## CAUTION

Caution indicates a hazardous situation that, if not avoided, could result in minor or moderate injury.

## WARNING

Warning indicates a hazardous situation that, if not avoided, could result in death or serious injury.

## DANGER

Danger indicates a hazardous situation that, if not avoided, will result in death or serious injury.

### 1.3 Components and Operating Principles

#### 1.3.1 Components

**1.3.1.1** The replacement valve assembly includes: the valve assembly, a 1-1/2" nipple to connect the valve to the blast machine, a 1-1/4" nipple, and 1-1/4" wye to connect the valve to the blast machine piping.

#### 1.3.2 Operating Principles

**1.3.2.1 Manual Quantum PRO Metering Valve (MQV Pro):** Adjusts abrasive flow through the valve by turning the metering knob. Once the abrasive flow is set, the valve remains open at all times.

#### 1.3.2.2 Auto-Quantum Metering Valves (AQV):

The Auto-Quantum consists of two segments: metering segment and normally-closed actuator segment. The metering segment adjusts abrasive flow through the valve. The actuator segment opens, starting abrasive flow when control-air is applied, and closes, stopping abrasive flow when control-air is removed.

# QUANTUM ABRASIVE METERING VALVES

## 2.0 INSTALLATION

**2.1** Empty the blast machine of abrasive and depressurize the machine.

**2.2** Shut down the compressed air source and lockout and tagout the air supply.

### **WARNING**

Failure to observe the following before performing any maintenance on the blast machine could cause serious injury or death from the sudden release of trapped compressed air.

- Depressurize the blast machine.
- Lockout and tagout the compressed air supply.
- Bleed the air supply line to the blast machine.

**2.3** Remove the existing metering valve from the blast machine.

NOTE: To ensure airtight seals, use pipe sealant on all male pipe threads.

**2.4** Install the 1-1/4" nipple and wye to the metering valve as shown in Figure 1. NOTE: A 1-1/2" wye is available for 1-1/2" piping. Refer to Page 10, Figure 10 and Page 11, Figure 11.

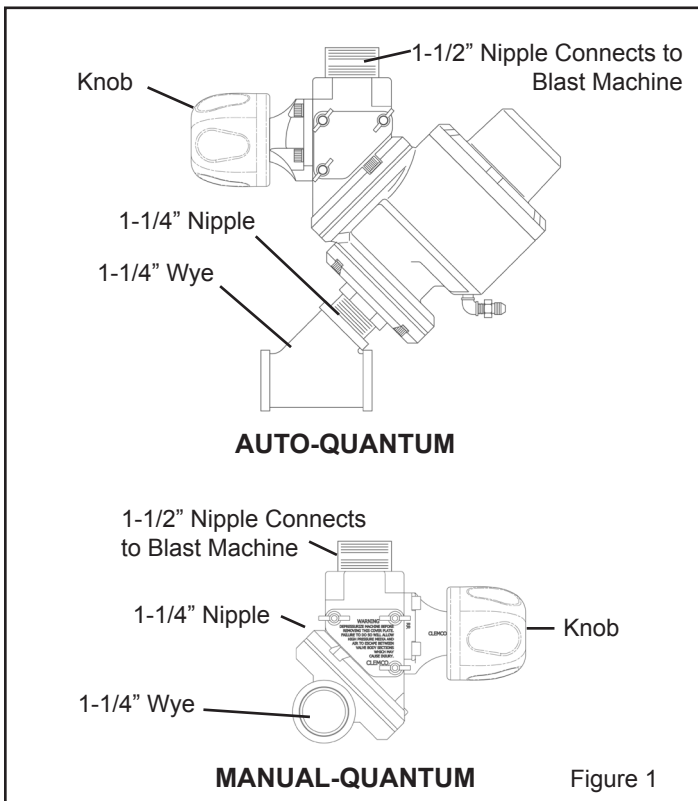

**NOTE:** The following describes installation of the Auto-Quantum valve on a machine with minimal rotation clearance. If the valve assembly will freely rotate beneath the blast machine, it may be installed as a unit.

**2.5** Remove the four socket head screws holding the metering segment to the actuator, and remove the actuator assembly as shown in Figure 2.

**2.6** Use the 1-1/2" x close, schedule 80 pipe nipple to connect the metering segment to the outlet at the bottom of the blast machine. Position the metering knob as shown in the illustrations.

**2.7** Make sure the flange gasket is in place, and bolt the actuator to the metering segment.

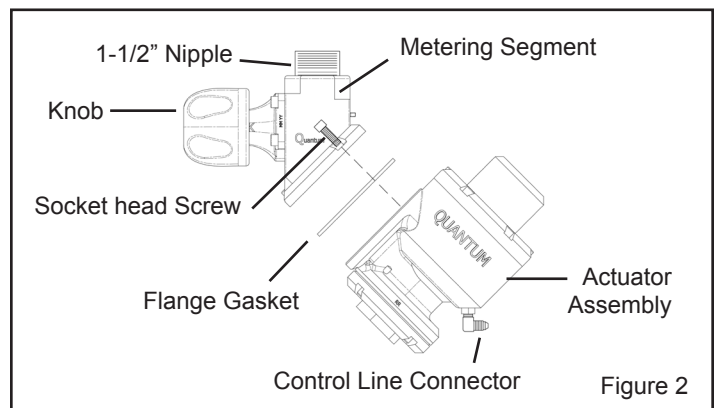

**2.8** Some vertical and horizontal piping realignment may be required to reinstall the pusher line.

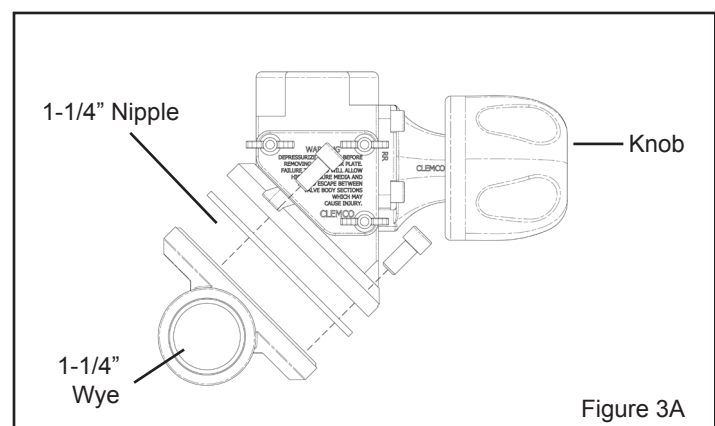
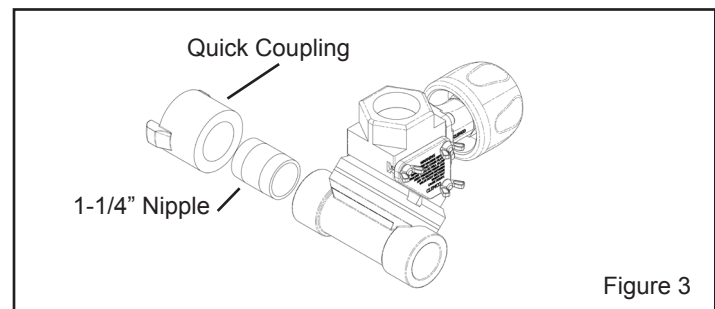

# QUANTUM ABRASIVE METERING VALVES

**2.9** Install a coupling and nipple to the wye as shown in Figure 3.

**2.10** On AQV valves only, connect the control line to the elbow on the bottom of the actuator assembly, shown in Figure 2.

## 3.0 ADJUST ABRASIVE FLOW, Figure 4

**3.1** Adjust abrasive flow by turning the knob on the metering valve located at the bottom of the blast machine. Use the metering knob to adjust abrasive flow.

**3.2** The hole in the knob is a rotation reference enabling the operator to monitor its rotation and count turns as the knob is rotated. The reference hole helps return the setting to its original position, should temporary adjustments be required.

**3.3** The valve is closed when the knob has been turned fully clockwise. Begin with the knob set 1-1/2 turns from fully closed. To increase abrasive flow, the machine tender turns the knob no more than 1/4 turn counterclockwise while the operator is blasting. Allow 10 to 15 seconds for the flow to stabilize before readjusting. Continue making adjustments as described until the ideal flow is attained.

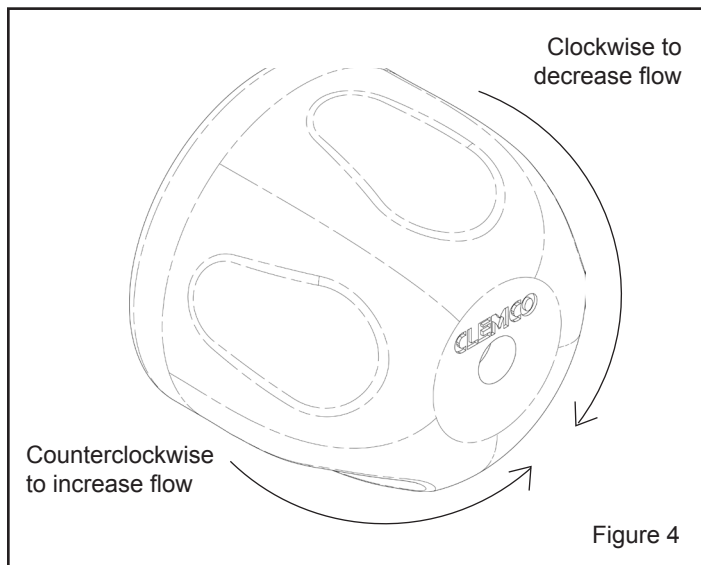

**3.4** Optimum abrasive flow depends on the type and size of abrasive and blasting pressure, and is best determined by experience. Use as little abrasive as possible while maintaining the maximum cleaning rate. The air/abrasive mixture should be mainly air. As a rule, the stream of abrasive coming out of the nozzle should barely discolor the air when seen against a contrasting background.

## 4.0 MAINTENANCE

### **WARNING**

**Failure to observe the following before performing any maintenance on the blast machine could cause serious injury or death from the sudden release of compressed air.**

- **Depressurize the blast machine.**
- **Lockout and tagout the compressed air supply.**
- **Bleed the air supply line to the blast machine.**

**NOTE: Service kits are available for the Quantum metering assembly and actuator segments. Keeping kit(s) on-hand will eliminate unnecessary downtime. Replace all seals provided in the kit whenever the valve is opened.**

**If immediate service is required and a service kit is not readily available, take extreme care not to misplace or damage o-rings, gaskets, or other seals. Thoroughly clean all reusable parts.**

### 4.1 Metering Assembly, Ref. Figure 5

**Refer to Section 4.2 for servicing the Auto Quantum actuator segment.**

**4.1.1** Empty the machine of abrasive. Turn off then compressed air supply. Lockout and tagout the air supply, and bleed the air supply line to the blast machine.

**4.1.2** Remove the inspection plate wing nuts and inspection plate.

**4.1.3** Remove the four socket head screws securing the metering housing, and remove the housing assembly.

**4.1.4** The adaptor flange and actuator do not need to be removed from the blast machine to service the metering assembly. Thoroughly inspect the adaptor flange for wear, and replace it if worn.

**4.1.5** Turn the metering shaft clockwise to remove the shaft from the metering screw.

**4.1.6** Loosen the knob nut, and pull the knob assembly from the housing.

**4.1.7** Use a 2/16" hex bit socket head screw, and remove the knob.

# QUANTUM ABRASIVE METERING VALVES

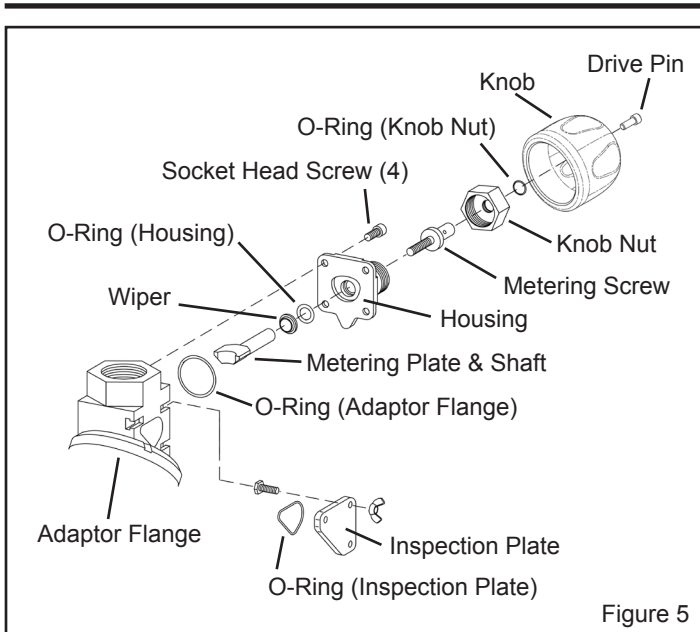

**4.1.8** Remove the metering screw by pushing it out the front of the knob nut.

**4.1.9** Inspect the metering screw for damage and any signs of abrasive ingress or metal filings.

**4.1.10** Clean the metering screw threads, and test the condition of the threads by installing the screw into the metering plate shaft. Replace the metering screw if there is any resistance, binding or metal filings.

**4.1.11** Remove the o-ring from the knob nut, and remove the o-ring and wiper from the housing.

**4.1.12** Thoroughly clean and inspect all parts that are to be reused. Replace all worn parts.

**4.1.13** Place a new o-ring in the knob nut.

**4.1.14** Place a new o-ring and wiper seal in the housing. A generous amount of silicone-based lubricant eases installation. The small side of the wiper seal faces away from the o-ring.

**4.1.15** Insert the metering plate shaft through the housing bore, and wipe off any lubricant on the metering plate side of the bore.

**4.1.16** Reassemble the metering screw, nut, knob, and drive pin. Note: applying a small amount of siliconebased lubricant on the unthreaded end of the metering shaft eases insertion through the nut o-ring.

**4.1.17** Apply a molybdenum disulfide or graphite-based anti-seize lubricant to the metering shaft and metering screw threads, and thread the shaft onto the screw.

**4.1.18** Place a new o-ring in the groove on the face of the adaptor flange.

**4.1.19** Insert the metering plate (flat side up) through the adaptor flange opening. Be careful not to displace the o-ring.

**4.1.20** Secure the metering housing finger-tight before tightening all screws.

**4.1.21** Place a new o-ring on the inspection plate, and securely attach the plate.

**4.1.22** Once service of the metering assembly is complete, test the machine and piping for air leaks before returning to service.

## 4.2 Actuator Segment

Refer to Section 4.1 for servicing the manual valve, and the metering assembly of the auto valve.

**NOTE:** A rubber piston-cup and bushing replaces the machined aluminum piston and u-seal. The aluminum piston is no longer available; replacing it with the rubber piston-cup and bushing is recommended when service is required on the actuator.

**4.2.1** Empty all abrasive from the machine per instructions supplied with the blast machine. NOTE: If the metering assembly does not require service, abrasive flow may be shut off by closing the metering valve.

**4.2.2** Turn off the compressed air supply. Lockout and tagout the air supply, and bleed the air supply line to the blast machine.

**4.2.3** Disconnect the control line from the fitting on the actuator assembly

**4.2.4** Refer to Figure 6 and remove the screws securing the adaptor flange and the outlet flange to the actuator assembly, and then remove the actuator assembly.

**4.2.5** Refer to Figure 7 and unscrew the six socket head screws, and remove the cylinder cover and spring. Spring compression is relieved when the cover is approximately 9/16" from the actuator valve body.

**4.2.6** Remove the felt disc from inside the cylinder cap.

**4.2.7** Use a hammer handle or similar object to push the bottom of the plunger, forcing the plunger/piston assembly out the top of the valve body cylinder.



# QUANTUM ABRASIVE METERING VALVES

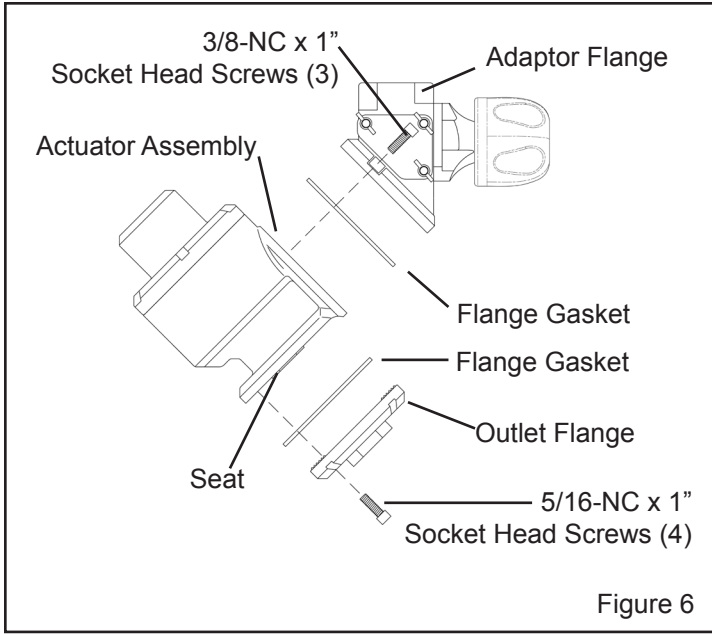

**4.2.10** It is not necessary to separate the plunger from the piston unless either part is scored or worn. To separate the parts, hold the plunger in a vise with the vise jaws covered with copper or similar protection (if the plunger is damaged it does not matter if the vise jaws mar the plunger). Using a wrench placed on the flats of the piston stop, unscrew the stop. **NOTE:** if the piston is aluminum, replace it with the rubber piston-cup and bushing. The bushing flange must be placed as shown in Figure 7, on the top side of the piston-cup, facing toward the piston stop.

**4.2.11** Remove the wiper and o-ring from the actuator valve body.

**4.2.12** Inspect the urethane seat. Replace if worn or damaged.

**4.2.13** Inspect the abrasive path in the actuator valve body, adaptor flange and outlet flange for wear. Replace if worn.

**4.2.14** Clean all items and inspect for wear. Replace worn or damaged parts.

**4.2.15** If the plunger and piston were separated as noted in Section 4.2.10, apply removable thread sealant to the threads on the piston stop and reassemble the parts using a new o-ring. Make sure the bushing is installed in the piston as shown in Figure 7.

**NOTE:** If servicing an AQV-H actuator, which is identified by an "H" stamped in the side of the actuator body and at the end of the plunger, proceed to Section 4.3.

**4.2.8** Pry the urethane seat from the bottom of the actuator valve body.

**4.2.9** Remove the wear sleeve and roll pin from the body. A puller may be needed to remove the wear sleeve.

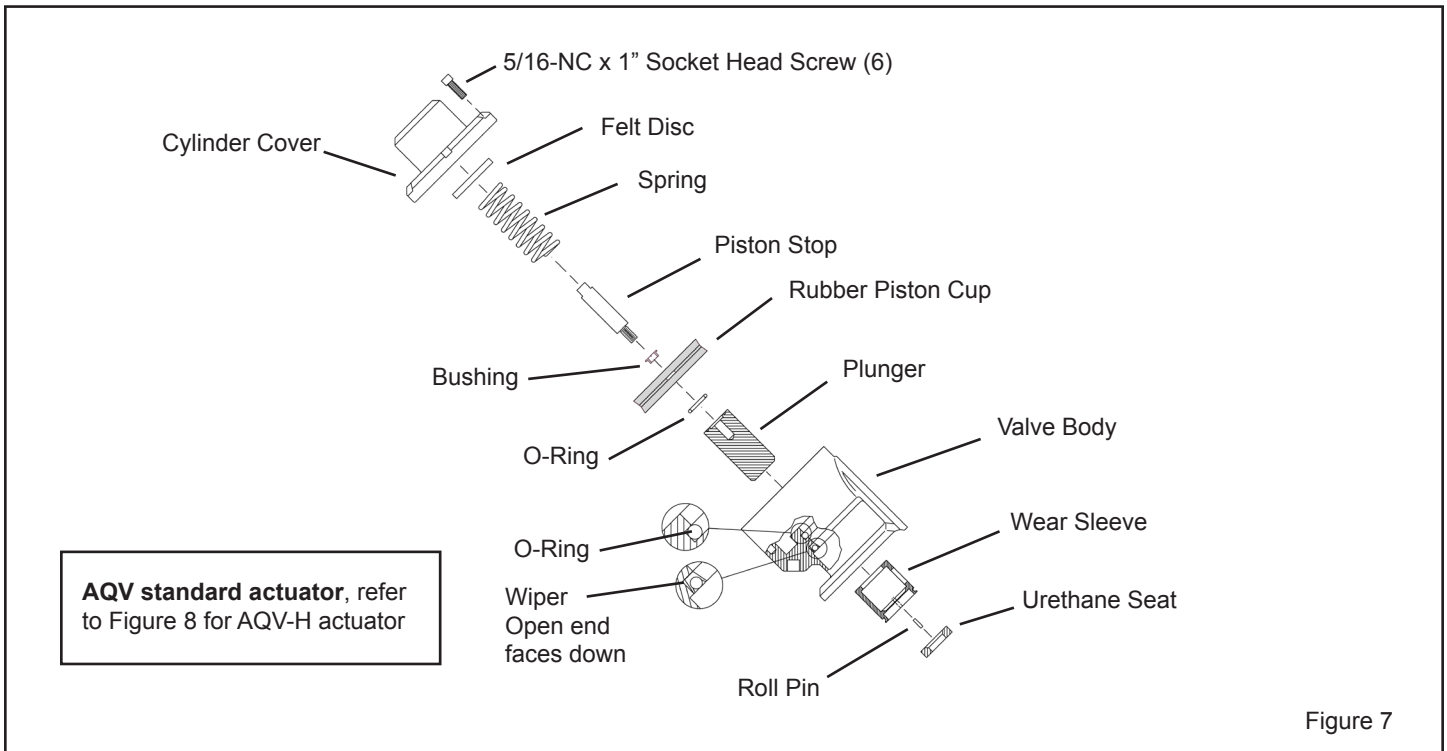

# QUANTUM ABRASIVE METERING VALVES

**4.2.16** Replace the wiper and o-ring in the actuator body; the o-ring side of the wiper must face toward the bottom of the body as shown in Figure 7.

**4.2.17** Lubricate the o-ring and wiper in the actuator body with a silicone-based lubricant.

**4.2.18** Lubricate the body's cylinder wall with tool oil or 10 wt. oil.

**4.2.19** Install the plunger and piston assembly into the body. Make sure the bottom side of the piston cup does not fold back during assembly. Tucking in the lip of the cup, while applying pressure to the piston, eases assembly.

**4.2.20** Place the roll pin and wear sleeve in the actuator body. The wear sleeve is correctly positioned when the alignment slot in the sleeve fits the roll pin in the body.

**4.2.21** Place the urethane seat into the wear sleeve, with the beveled side toward the sleeve.

**4.2.22** Assemble the actuator assembly onto the adaptor flange and outlet flange. Note: The adaptor flange is secured with three screws, and the outlet flange is secured with four screws. The gaskets are the same for both parts.

Align the gaskets so the mounting holes match the pattern in the flange. First hand-tighten the outlet flange screws to the actuator valve body. Hand-tighten the adaptor flange screws before tightening all screws.

**4.2.23** Install the felt disc, spring, and cylinder cover, and tighten the screws to secure.

**4.2.24** Connect the control line to the fitting or port on the actuator assembly, and test the operation before putting the valve in service.

## 4.3 Service for AQV-H Actuator Only, Continued from paragraph 4.2.7, Refer to Figure 8

**4.3.1** Pry the urethane wear sleeve from the bottom of the actuator valve body.

**4.3.2** It is not necessary to separate the plunger from the piston unless either part is scored or worn. To separate the parts, hold the plunger in a vise with the vise jaws covered with copper or similar protection (if the plunger is damaged it does not matter if the vise jaws mar the plunger). Using a wrench placed on the flats of the piston stop, unscrew the stop.

**4.3.3** Remove the wiper and o-ring from the valve body.

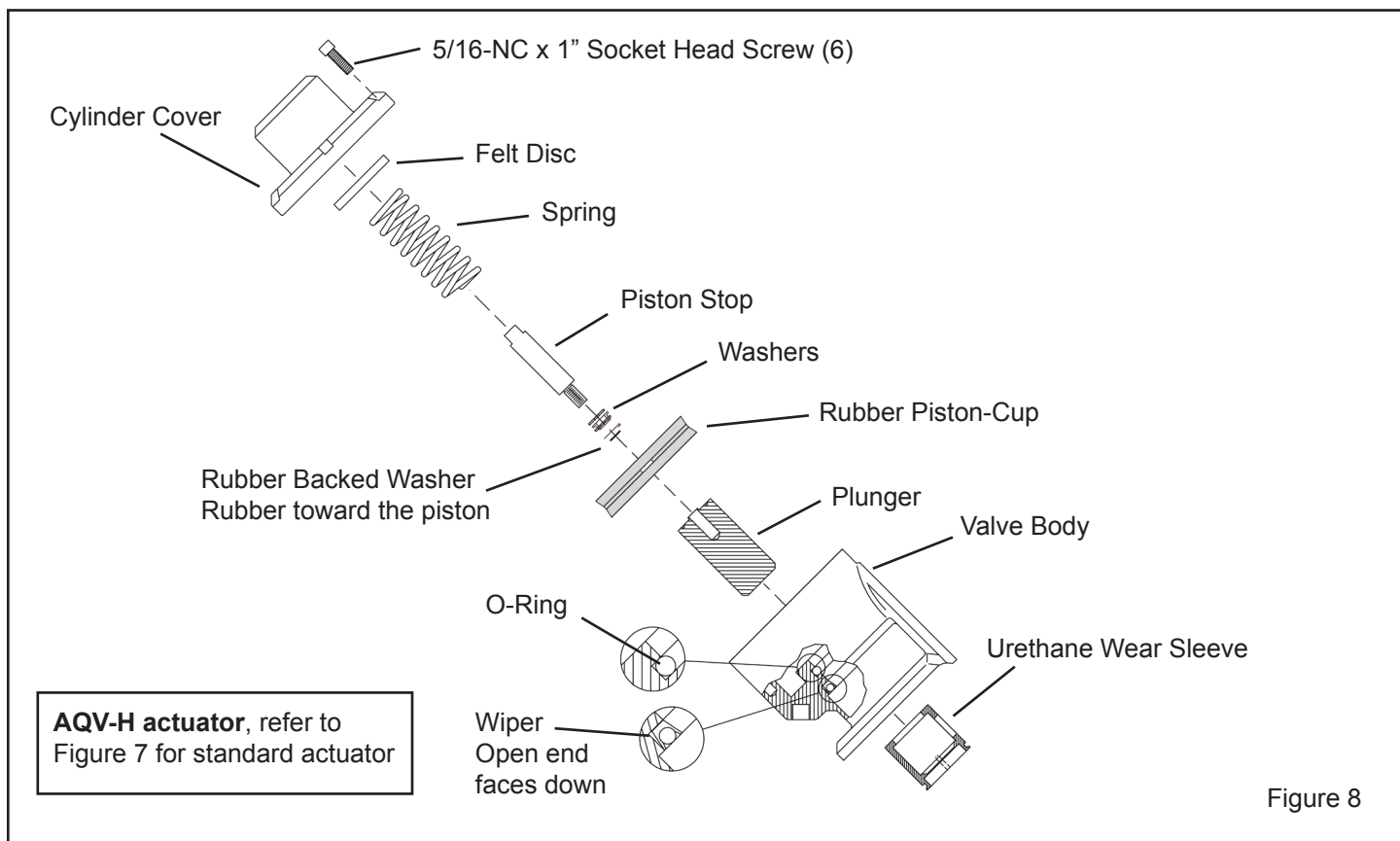

# QUANTUM ABRASIVE METERING VALVES

**4.3.4** Inspect the abrasive path in the actuator valve body, adaptor flange and outlet flange for wear. Replace if worn.

**4.3.5** Clean all items and inspect for wear. Replace worn or damaged parts.

**4.3.6** If the plunger and piston were separated as noted in Section 4.3.2, apply removable thread sealant to the threads on the piston stop, and reassemble the piston assembly using a new o-ring from the service kit. NOTE: Make sure the two flat washers and rubber backed washer are installed as shown in Figure 8.

**4.3.7** Replace the wiper and o-ring in the actuator body; the open side of the wiper must face toward the bottom of the body as shown in Figure 8.

**4.3.8** Lubricate the o-ring and wiper in the actuator body, with a silicone-based lubricant.

**4.3.9** Lubricate the body's cylinder wall tool oil or 10 wt. oil.

**4.3.10** Install the plunger-piston assembly into the body. Make sure the bottom side of the piston cup does not fold back during assembly. Tucking in the lip of the cup, while applying pressure to the piston, eases assembly.

**4.3.11** Place the urethane wear sleeve in the actuator body. Align the ridge in the wear sleeve with the slot in the body.

**4.3.12** Assemble the actuator assembly onto the adaptor flange and outlet flange. Note: The adaptor flange is secured with three screws, and the outlet flange is secured with four screws. The gaskets are the same for both parts. Align the gaskets so the mounting holes match the pattern in the flange. First hand-tighten the outlet flange screws to the actuator valve body. Hand-tighten the adaptor flange screws before tightening all screws.

**4.3.13** Place the two flat washers and spring over the piston stop as shown in Figure 2.

**4.3.14** Install the felt disc in the cylinder cover and assemble the cover, tighten the screws to secure.

**4.3.15** Connect the control line to the fitting or port on the actuator assembly, and test the operation before putting the valve in service.

## 5.0 TROUBLESHOOTING

### 5.1 No Abrasive Flow

**5.1.1** Metering valve closed. Adjust abrasive flow per Section 3.0.

**5.1.2** Optional ACS switch is closed. Switch is closed when the toggle is pointed toward the "EXH" port.

**5.1.3** Leak or blockage in the air hose or fittings between the control unit and the Quantum valve.

**5.1.4** Machine empty.

**5.1.5** Obstruction in metering valve. Clear as follows:

**5.1.5.1** Fully open the control valve, (It is fully open when the metering knob is turned fully counterclockwise). While blasting, close the choke valve to force out small obstructions or wet abrasive.

## WARNING

**To avoid serious injury, depressurize the blast machine, lockout and tagout the compressed air supply before continuing.**

**5.1.5.2** For larger obstructions, shut the machine down to examine the abrasive valve. Remove the inspection plate from the flanged adaptor and clear obstruction.

**5.1.6** Relief hole in cylinder cap is plugged.

**5.1.7** Air leak through relief hole in cylinder cap. Check for leak. A leak at the vent indicates a worn or damaged piston cup. Service the actuator per Section 4.2.

**5.1.8** Abrasive bridging in the blast machine. Refer to Section 5.6.

**5.2** Abrasive Flow Does Not Stop When Optional ACS Switch is Turned to OFF

**5.2.1** Control air is not exhausting from the switch. Check the exhaust muffler for blockage and check the control handle per the control handle owner's manual.

**5.2.2** Worn urethane seat. Service the actuator per Section 4.2.

**5.2.3** Worn plunger. Service actuator per Section 4.2.



# QUANTUM ABRASIVE METERING VALVES

**5.2.4** Obstruction on the valve seat. Service the actuator per Section 4.2.

## **5.3 Turning Metering Knob Does Not Change Abrasive Flow**

**5.3.1** Inspect metering segment per Section 4.1.

## **5.4 Air Leaks Through Relief Hole in Cylinder Cap**

**5.4.1** Worn piston cup. Service the actuator per Section 4.2.

## **5.5 Abrasive Flow Decreases Shortly After Blasting Starts**

**5.5.1** Insufficient air supply causes control pressure to drop, in turn closing the valve. Check for undersized air supply hose, and the cfm of compressor against the cfm consumption of the nozzle.

**5.5.2** Abrasive bridging in the blast machine. This is usually caused by using very fine abrasive, or by moist air. Refer to Section 5.6.

## **5.6 Abrasive Bridging**

**5.6.1** Frequent bridging or blockage in the blast machine and metering valve can be caused by damp abrasive. Blast media becomes damp by blasting parts that are slightly oily (when using recycled abrasive), from moisture in the compressed air line, or from absorption from ambient air.

**5.6.2** To avoid contaminating recyclable abrasive by the workpiece, all parts should be clean and dry. If parts are oily or greasy, degrease and dry them prior to blasting.

**5.6.3** Moist compressed air: Moisture in the air supply may be due to a faulty compressor that overheats, or pumps oil or moisture into the air line; an air line that is too long permitting moisture to condense on the inside; and from high humidity. Drain filters and receiver tank regularly. If the problem persists, a dryer or aftercooler may be required in the air supply line.

**5.6.4** Absorption: Some abrasive tends to absorb moisture from the air, especially fine-mesh abrasive in high humidity areas. Empty abrasive from the blast machine at the end of the work day, and store it in an area protected from damp environment.

**5.6.5** Condensation: When working in conditions of extreme temperature change or humidity, condensation may develop inside the machine. Condensation dampens abrasive and causes flow problems. Empty the machine of all abrasive, when shutting down for the day. This will eliminate trouble from moist abrasive the next time the machine is started.

## **REPLACEMENT PARTS**

### **6.1 Replacement Metering Valves**

<b>Item</b>	<b>Description</b>	<b>Stock No.</b>
(-)	MQV PRO Manual Quantum Pro metering valve with 1-1/4" wye .....	31607
(-)	MQV PRO Manual Quantum Pro metering valve with 1-1/2" wye .....	31608
(-)	AQV Auto-Quantum, metering valve with fittings and 1-1/4" wye .....	24447
(-)	AQV Auto-Quantum, metering valve with fittings and 1-1/2" wye .....	25281
(-)	AQV-H, Auto Quantum metering valve coarse mesh with fittings and 1-1/4" wye .....	27525

# QUANTUM ABRASIVE METERING VALVES

## 6.2 Manual Quantum Abrasive Metering Valve Figure 9

Item	Description	Stock No.
*	Service kit, metering assembly (Fig. 9a) .....	22854
1.	Adaptor flange .....	21314
2.	Screw, 3/8-NC x 1" socket head .....	22655
3.	Flange, threaded outlet .....	
3a.	Outlet Pipe, 1-1/4" NPT, MQV PRO.....	31606
3b.	Outlet Pipe, 1-1/2" NPT, MQV PRO.....	31605
4.	Cover, cleanout .....	22620
5.	Screw, 1/4-NC x 3/4" hex head cap .....	03052
6.	Nut, 1/4-NC wing .....	03113
7.	Housing, knob .....	22761
8.	Nut, knob housing .....	22762
9.	Metering plate and shaft .....	22763
10.	Metering screw .....	22764
11.	Knob, adjustment .....	31187
12.	Screw, 5/16-NC x 3/4" socket head .....	22767
13.	Nipple, 1-1/2" x 2" heavy wall .....	01840

### 22854 SERVICE KIT QUANTUM METERING ASSEMBLY

Item	Qty	Description
1.	1	Flange gasket
2.	1	Wiper seal
3.	1	O-ring, 3/4" OD nominal
4.	1	O-ring, 5/8" OD nominal
5.	2	O-ring 1-1/2" ID nominal
6.	1	3/16 x 5/8" Hex Screw

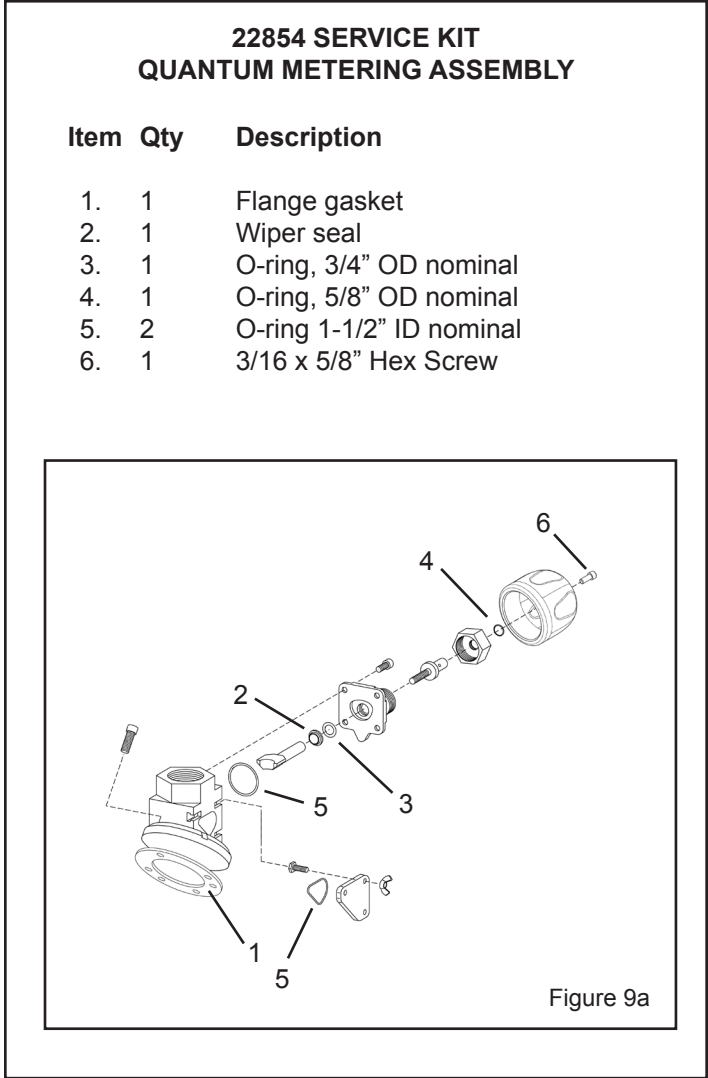
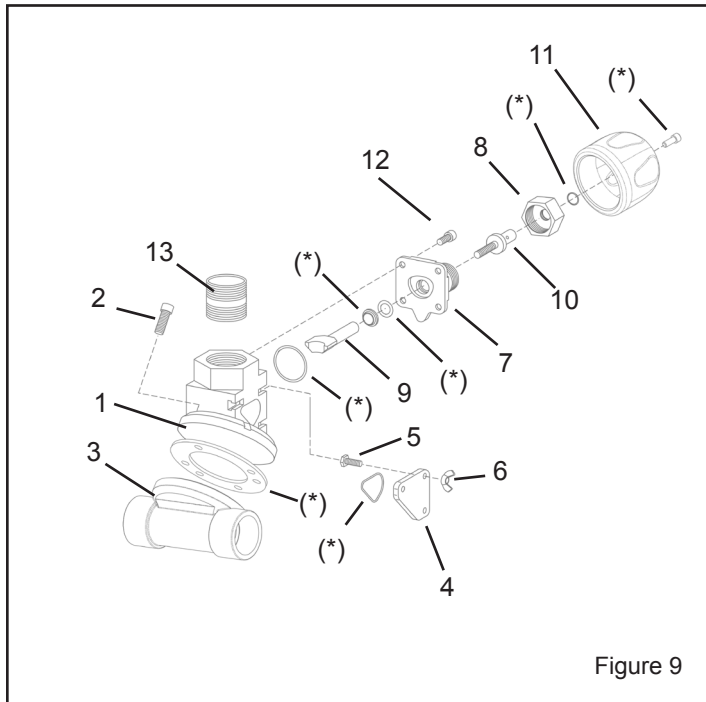

# QUANTUM ABRASIVE METERING VALVES

## 6.3 AQV Auto Quantum Actuator, Figure 10 Refer to 6.4 for AQV-H Actuator

Item	Description	Stock No.
(-)	Conversion kit, AQV to AQV-H Converts Standard Actuator to AQV-H actuator .....	27621
(-)	Actuator assembly, AQV (Items w/ ( ) .....	22775
	* Service kit, Quant. actuator, See Fig. 10a ..	24446
1.	Cover, cylinder .....	21317
2.	Stop, piston .....	21323
3.	Piston cup w/bushing .....	21329
4.	Valve body, actuator .....	21349
5.	Plunger, grit valve .....	21326
6.	Wear sleeve, grit valve .....	21342
7.	Seat, urethane .....	21344
8.	Flange, threaded outlet w/retaining ridge .....	21319
9.	Screw, 5/16-NC x 1-3/4" socket head .....	21321
10.	Screw, 5/16-NC x 1" socket head .....	21318
11.	Spring .....	20600
12.	Retaining ring (for replacement parts only) Not required with current Item 8 .....	22429
13.	Adaptor, 1/4" NPT elbow .....	02513
14.	Petcock, 1/4" NPT .....	01993
15.	Nipple, 1-1/2" x close, schedule 80 .....	01791
16.	Nipple, 1-1/4" x 2" .....	01718
17.	Wye, 1-1/4" NPT .....	01818
18.	Screw, 3/8-NC x 3/4" LG socket head .....	22655

Item	Description	Stock No.
19.	Wye, 1-1/2" NPT .....	01819
20.	Bushing, 1-1/2 NPT x 1-1/4 NPT .....	01805
21.	Nipple, 1-1/4 x close HD .....	01854
22.	Metering assembly, Quantum .....	24587

*Refer to Section 6.2 for replacement parts*

### 24446 SERVICE KIT QUANTUM ACTUATOR ASSEMBLY

Item	Qty	Description
1.	1	Seat, urethane
2.	2	Flange gasket
3.	1	U-seal, 3-1/2" ID (used only w/ alum piston)
4.	1	O-ring, 1-1/2" ID x 3/16" nom.
5.	1	Wiper, plunger
6.	1	O-ring, 31/64" ID
7.	1	Roll pin, 1/8" x 1/2"
8.	1	O-ring, 1-1/2" ID x 3/32" nom.
9	1	Felt disc
10	1	Washer, rubber backed
11	2	Washer, 3/4 flat

NOTE: Item 8 is not required with current 21319 outlet flange with integrated retaining ridge. Used only with earlier style 22077 flange, requiring a separate 22429 Retaining Ring.

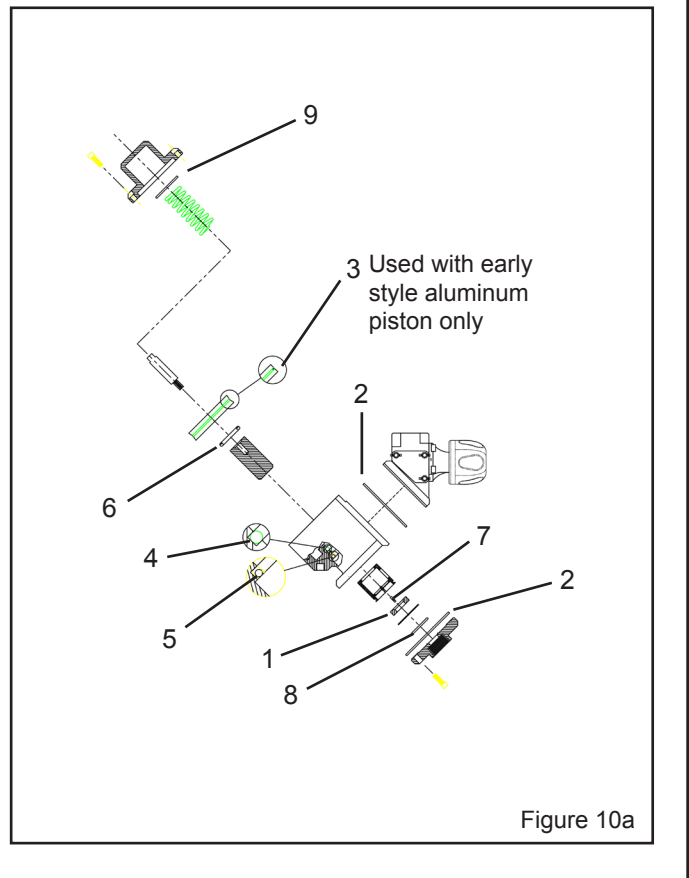
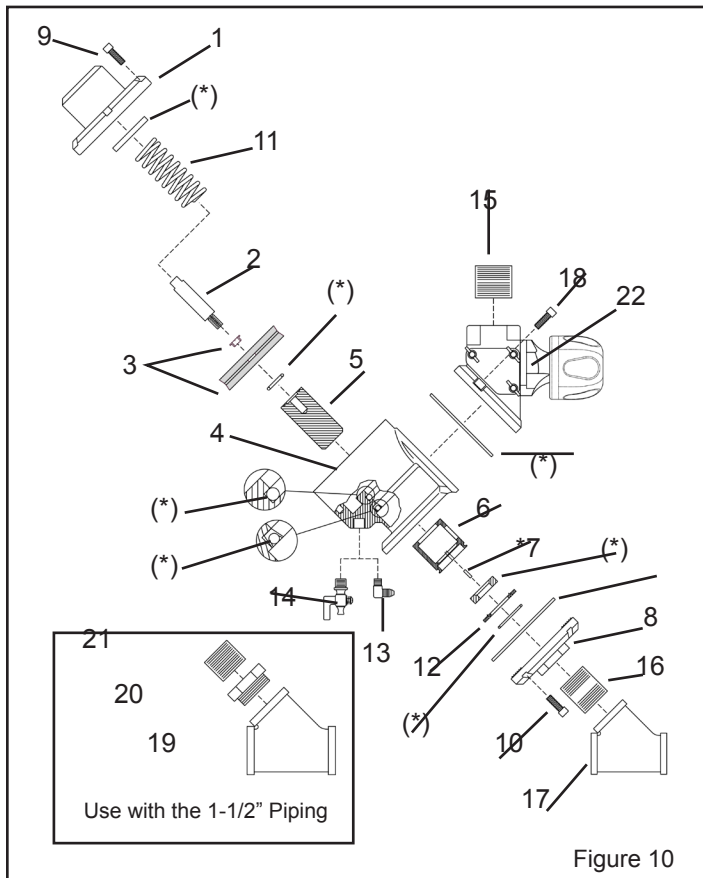

# QUANTUM ABRASIVE METERING VALVES

## 6.4 AQV-H Auto Quantum Actuator, Figure 11

Refer to 6.3 for standard AQV actuator

Item	Description	Stock No.
(-)	Actuator assembly, AQV-H (Items w/ ( )	27620
*	Service kit, Quant. actuator, See Fig. 11a	24446
1.	Cover, cylinder	21317
2.	Stop, piston	21323
3.	Piston cup	20515
4.	Valve body, actuator	21349
5.	Plunger, AQV-H	27523
6.	Wear sleeve, urethane, AQV-H	27521
7.	Flange, threaded outlet w/retaining ridge	21319
8.	Screw, 5/16-NC x 1-3/4" socket head	21321
9.	Screw, 5/16-NC x 1" socket head	21318
10.	Spring, AQV-H	27524
11.	Adaptor, 1/4" NPT elbow	02513
12.	Petcock, 1/4" NPT	01993
13.	Screw, 3/8-NC x 3/4" LG socket head	22655
14.	Nipple, 1-1/2" x close, schedule 80	01791
15.	Nipple, 1-1/4" x 2"	01718
16.	Wye, 1-1/4" NPT	01818
17.	Wye, 1-1/2" NPT	01819
18.	Bushing, 1-1/2 NPT x 1-1/4 NPT	01805
19.	Nipple, 1-1/4 x close HD	01854
20.	Metering assembly, Quantum	24587

Refer to Section 6.2 for replacement parts

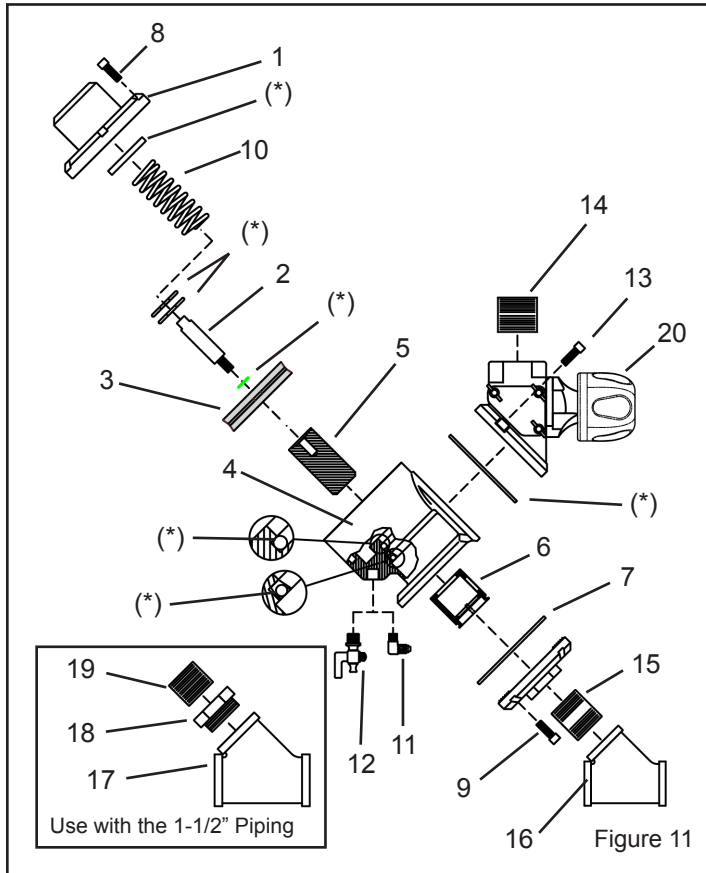

## 24446 SERVICE KIT QUANTUM ACTUATOR ASSEMBLY

Item	Qty	Description
1.	1	Seat, urethane
2.	2	Flange gasket
3.	1	U-seal, 3-1/2" ID (used only w/ alum piston)
4.	1	O-ring, 1-1/2" ID x 3/16" nom.
5.	1	Wiper, plunger
6.	1	O-ring, 31/64" ID
7.	1	Roll pin, 1/8" x 1/2"
8.	1	O-ring, 1-1/2" ID x 3/32" nom.
9.	1	Felt disc
10.	1	Washer, rubber backed
11.	2	Washer, 3/4 flat

**NOTE:** Items 1, 6, 7, and 8 used with standard AQV actuator only.

