

INEX SUCTION CABINET

With 300 CFM Reclaimer

O. M. 21803

DATE OF ISSUE: 12/96
REVISION: F 07/16

NOTICE TO PURCHASERS AND USERS OF OUR PRODUCTS AND THIS INFORMATIONAL MATERIAL

Clemco proudly provides products for the abrasive blast industry and is confident that industry professionals will use their knowledge and expertise for the safe and efficient use of these products.

The products described in this material, and the information relating to these products, are intended for knowledgeable, experienced users. It is the responsibility of the user to insure that proper training of operators has been performed and a safe work environment is provided.

No representation is intended or made as to: the suitability of the products described here for any purpose or application, or to the efficiency, production rate, or useful life of these products. All estimates regarding production rates or finishes are the responsibility of the user and must be derived solely from the user's experience and expertise, not from information contained in this material.

It is possible that the products described in this material may be combined with other products by the user for purposes determined solely by the user. No representations are intended or made as to the suitability of or engineering balance of or compliance with regulations or standard practice of any such combination of products or components the user may employ.

This equipment is only one component of a cabinet blasting operation. Other products, such as air compressors, air filters and receivers, abrasives, equipment for ventilating, dehumidifying, or other equipment, even if offered by Clemco, may have been manufactured or supplied by others. The information Clemco provides is intended to support the products Clemco manufactures. Users must contact each manufacturer and supplier of products used in the blast operation for warnings, information, training, and instruction relating to the proper and safe use of their equipment.

© 2016 CLEMCO INDUSTRIES CORP.
One Cable Car Dr.
Washington, MO 63090
Phone (636) 239-4300
Fax (800) 726-7559
Email: info@clemcoindustries.com
www.clemcoindustries.com



1.0 INTRODUCTION

1.1 Scope of Manual

1.1.1 These instructions cover set-up, operation, maintenance, troubleshooting, optional accessories, and replacement parts for the INEX suction blast cabinet with 300 cfm pull-thru reclaimer and dust collector. Refer to the CDC-1 dust collector manual, stock no. 28225, for operation and maintenance of the collector.

1.1.2 These instructions also contain important information required for safe operation of the cabinet. Before using this equipment, all personnel associated with the blast cabinet operation must read this entire manual, and all accessory manuals to become familiar with the operation, parts and terminology.

1.2 Safety Alerts

1.2.1 Clemco uses safety alert signal words, based on ANSI Z535.4-2011, to alert the user of a potentially hazardous situation that may be encountered while operating this equipment. ANSI's definitions of the signal words are as follows:



This is the safety alert symbol. It is used to alert you to potential physical injury hazards. Obey all safety messages that follow this symbol to avoid possible injury or death.

NOTICE

Notice indicates information that is considered important, but not hazard-related, if not avoided, could result in property damage.

⚠ CAUTION

Caution indicates a hazardous situation that, if not avoided, could result in minor or moderate injury.

⚠ WARNING

Warning indicates a hazardous situation that, if not avoided, could result in death or serious injury.

⚠ DANGER

Danger indicates a hazardous situation that, if not avoided, will result in death or serious injury.

1.3 General Description

1.3.1 Refer to Figure 1 for arrangement of components. INEX blast cabinets enclose the blasting environment to provide efficient blasting while maintaining a clean surrounding work area. Production rates are influenced by size of nozzle, compressor output, working pressure, type and size of media, angle and distance of the nozzle from the blast surface. INEX cabinets consist of three major components:

1. Cabinet Enclosure
2. Reclaimer
3. Dust Collector

1.4 Theory of Operation

1.4.1 Once the components are correctly setup and turned ON, the cabinet is ready for operation by actuation of the foot pedal. Fully depressing the foot pedal causes air to flow through the blast gun. Air moving through the gun draws media into the gun's mixing chamber. The media mixes with the air and is propelled out the nozzle. After striking the object being blasted, the blast media, fines, dust, and by-products generated by blasting, fall through the mesh work table into the cabinet hopper. These particles are then drawn into the reclaimer for separation. Lightweight dust and fines remain airborne and are drawn out to the dust collector. Heavier reusable media fall through the screen into the reclaimer hopper for reuse. The dust collector traps dust and fines and discharges clean air. When the foot pedal is released, blasting stops.

1.5 Dust Collector

⚠ WARNING

Prolonged exposure to any dust could result in serious lung disease and death. Short term ingestion of toxic materials, such as lead dust or dust from other heavy metals and corrosives, could cause serious respiratory injury or death. Identify all materials that are to be removed by blasting. Use reverse-pulse dust collectors with HEPA after-filters if lead coating or any other toxic materials are being removed by the blasting process. Do not use dust collectors with simple cloth filters for those applications.

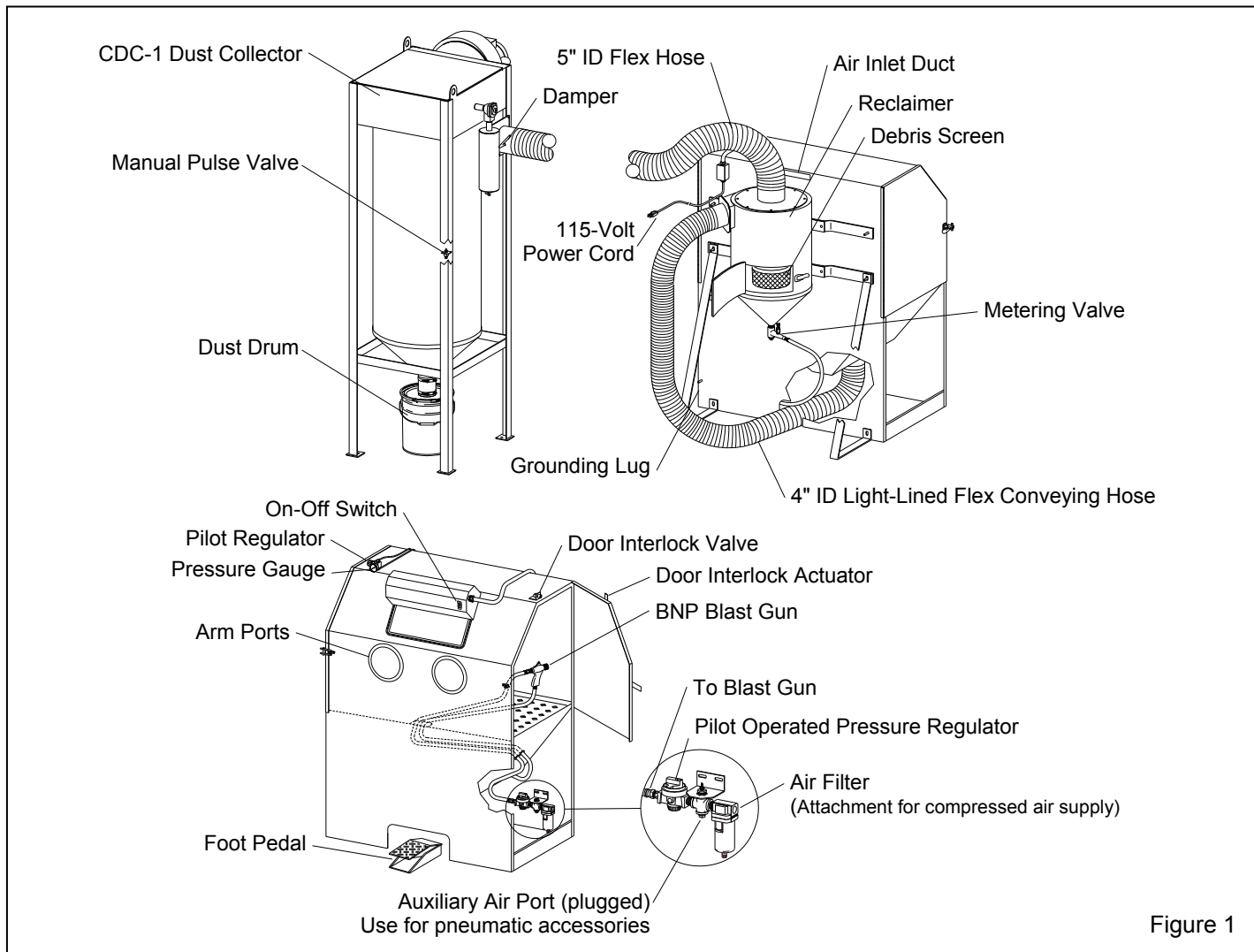

Figure 1

1.5.1 CDC-1 Dust Collectors: A 300 cfm dust collector is provided with the INEX cabinet. The single filter cartridge is cleaned by using a manually-controlled pulse of compressed air. Refer to manual no. 28225 for operation of the CDC-1 dust collector.

1.5.2 HEPA (high-efficiency particulate air) Filter: HEPA after-filters provide additional filtration and must be used with a reverse-pulse cartridge collectors when removing lead coatings or any other toxic materials.

1.6 Nozzle Options

1.6.1 Unless otherwise specified at the time of order, cabinets are shipped with a 5/16" orifice ceramic nozzle and No. 5 (5/32" orifice) air jet. Optional, more durable tungsten carbide and boron carbide nozzles are available and shown under Accessories and Replacement Parts in Sections 8.1 and 8.3. Use a boron carbide nozzle when blasting with aggressive media, as noted in Section 1.7.4.

1.7 Media

⚠ WARNING

Obtain Safety Data Sheets (SDS) for the blast abrasive. Abrasive blasting with sands containing crystalline (free) silica can lead to serious or fatal respiratory disease. As NIOSH recommends, do not use abrasives containing more than trace amounts (more than one percent) free silica.

NOTE: Use only abrasives specifically manufactured for blast cleaning and are compatible with the surface being blasted. Abrasive produced for other applications may be inconsistent in size and shape, contain particles that could jam the abrasive metering valve, or cause irregular wear.

1.7.1 INEX Suction Blast Cabinets utilize most common reusable media 60 to 180-mesh that is specifically manufactured for dry blasting. Media sizes listed are for

guidelines only. The guidelines are based on standard nozzle size and average conditions, such as blast pressure, media/air mixture, visibility inside the cabinet, humidity, and reclaimer cleaning rate. Several factors affecting the reclaimer cleaning rate include: reclaimer size, air pressure, media/air mixture, media friability, and contamination of parts being blasted.

As a rule, larger nozzles deliver more media, requiring higher performance from the reclaimer. When using larger nozzles, the maximum mesh size of media will be smaller than those normally recommended. Using media finer than those recommended may decrease visibility, and increase carryover to the dust collector. Media coarser than those recommended may be too dense for the reclaimer to recover from the cabinet hopper.

1.7.2 Steel: Steel grit or shot should not be used with the INEX Cabinet. The cabinet is too small to prevent peening of the cabinet weldment, and 300 cfm reclaimers are too small to efficiently convey metallic media.

1.7.3 Sand and Slag: Sand should NEVER be used because of the respiratory hazards associated with media containing free silica. Slags are not recommended because they rapidly breakdown and are not recyclable, making them unsuitable for cabinet applications.

1.7.4 Silicon Carbide, Aluminum Oxide, and Garnet: These are the most aggressive of the commonly used media. Aggressive media may be used occasionally by installing an optional aluminum oxide kit. The kit includes rubber curtains for the cabinet interior and a boron carbide lined nozzle. The service life of any equipment components exposed to the media will be reduced. To avoid unscheduled down time, periodically inspect the reclaimer wear plate, flex hoses, blast hose, and nozzle for abrasive wear. Using aggressive media on a regular bases will cause rapid wear on the reclaimer.

1.7.5 Glass Bead: Recommended bead sizes are No. 6 through No. 12. Most beads are treated to ensure free-flow operation even with moderately high-humidity. Glass beads subjected to excessive moisture may be reused after thorough drying and breaking up of any clumps.

1.7.6 Lightweight and Fine-mesh Media: When using lightweight (such as agricultural) media or fine mesh (180-mesh and finer) media, the reclaimer inlet baffle may need to be removed to retain media and avoid carryover. On reclaimer models with bolt-on removable tops, baffle removal and replacement is easily accomplished. Reclaimers with welded-on tops require grinding to remove the baffle and once it is removed it cannot be replaced.

1.7.7 Plastic Media: Plastic and similar lightweight and/or non-aggressive media are generally not recommended for suction-style cabinets because the lower blast velocity of suction blasting combined with the softer and lighter weight media, do not provide the media impact for productive blasting. Best performance from plastic media is achieved with pressure blasting, requiring a pressure vessel with a 60-degree conical bottom. Refer to Clemco's AEROLYTE cabinet line.

1.7.8 Bicarbonate of Soda: Bicarbonate of soda is not recommended for use in standard cabinets. Bicarb is a one-use media usually used and will quickly saturate the filter cartridge(s). Best performance from bicarb media is achieved with pressure blasting, requiring a pressure vessel. Refer to Clemco's AEROLYTE cabinet line for cabinets that are specifically designed for use with bicarbonate of soda.

1.8 Compressed Air Requirements

1.8.1 The size of the compressor required to operate the cabinet depends on the size of the air jet and blasting pressure. Unless otherwise specified, cabinets are supplied with a No. 5 (5/32" orifice) jet. Refer to the table in Figure 2 to determine cfm requirements. Consult with a compressor supplier for suggested compressor size based on the air consumption. **NOTE: A separate air line is required for the reverse-pulse dust collector. If preferred, remove the plug from the auxiliary air-port (shown in Figure 3) and connect a 1/4" ID or larger air line to the dust collector pulse reservoir/manifold.**

BNP Gun	Jet	Nozzle	CFM	PSI
No. 4	1/8"	5/16"	21	80
No. 5	5/32"	5/16"	32	80
No. 6	3/16"	3/8"	47	80
*No. 7	7/32"	7/16"	62	80
*No. 8	1/4"	1/2"	86	80

* Using this combination could affect usable media size, refer to Section 1.7.

Figure 2

1.8.2 The air filter at the air inlet connection reduces condensed water from the compressed air. Its use is especially important in areas of high humidity, or when using fine-mesh media. Moisture causes media to clump and inhibits free flow through the feed assembly. If the filter does not remove enough moisture to keep media dry and flowing, it may be necessary to install an air dryer or aftercooler in the air supply line.

1.9 Electrical Requirements

All wiring external to the cabinet is provided by the user to comply with local electrical codes.

1.9.1 Electrical requirements depend on the size and phase of the dust collector exhaust motor. NOTE: Full load amps (FLA) shown below are for the motor only; the lights draw less than one amp. Standard cabinets are supplied as follows:

300 cfm 1/2 HP, 115/208/230V, 1-PH, 60 HZ
 115, FLA 115/7, 208/3.4, 230/3.5.

Refer to Section 2.5 to connect electrical service

2.0 INSTALLATION

2.1 General Installation Notes

2.1.1 Refer to Figure 1 for the general arrangement and place all components in a convenient location where compressed air and electrical service are available. The cabinet location must comply with OSHA and local safety codes. Allow for full access to all doors and service areas, and for efficient handling of large parts. Provide enough clearance at the dust collector for maintenance and to remove the dust container. Determine the best location for all components and position them before making compressed air connections, electrical connections, and attaching flex hose.

2.1.2 Refer to the CDC-1 dust collector manual, stock no. 28225 to set up the dust collector and prepare it for operation.

2.2 Connect Conveying Hose

2.2.1 Connect the 4" diameter flex hose between the cabinet hopper pipe adaptor and reclaimer inlet adaptor, and connect the 5" diameter hose between the reclaimer outlet and dust collector inlet. It is easier to slip the hose over the adaptors and create a tighter seal if the first two or three inches of wire are removed from the inside of the hose. Use care not to damage the hose. Clamp flex hose securely in position with worm clamps provided. NOTE: The hose wire helps dissipate static electricity in the conveying hose, and also helps ground each segment. In order for the hose wire to dissipate static electricity, the wire must touch the metal of each segment.

2.3 Connect Compressed Air Supply Line(s)

⚠ WARNING

Failure to observe the following before connecting the equipment to the compressed air source could cause serious injury or death from the sudden release of compressed air.

- Lockout and tagout the compressed air supply.
- Bleed the compressed air supply line.

⚠ WARNING

To avoid the risk of injury from compressed air, install an isolation valve and bleed-off valve where the air supply is tapped into the compressed air system. This enables depressurization of the compressed-air line before performing maintenance.

2.3.1 Refer to Paragraph 2.3.2 to determine the recommended air supply hose size, then refer to Figure 3 and apply thread sealant to the male threads of an air fitting that is compatible with the air supply hose fitting, and install it onto the 1/2-NPT air filter located under the cabinet hopper. **Note that the style of connection shown in Figure 3 is for reference only.**

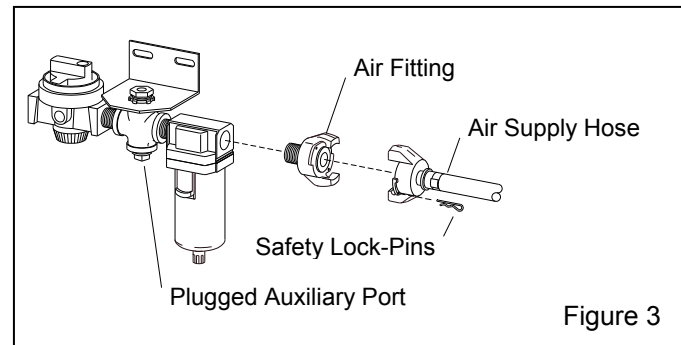

Figure 3

2.3.2 Refer to the table in Figure 4 to determine the minimum ID air supply line to the cabinet air inlet. A smaller diameter hose may reduce blasting efficiency.

MINIMUM COMPRESSED AIR LINE ID			
Air Jet Size			
Air Line Length	No. 4	No. 5	No. 6
25 feet	3/4"	3/4"	1"
50 feet	3/4"	3/4"	1"
75 feet	3/4"	1"	1"
100 feet	3/4"	1"	1"

Figure 4

2.3.3 Connect the air line from the air source to the air filter inlet.

⚠ WARNING

If twist-on type air hose couplings are used, they must be secured by safety pins or wires to prevent accidental disconnection while under pressure. Hose disconnection while under pressure could cause serious injury.

2.3.4 Refer to the dust collector owner’s manual and connect a compressed-air line to the pulse manifold.

2.4 Ground Cabinet

2.4.1 To prevent static electricity build up, attach an external grounded wire from an earth ground to the grounding lug on the left rear of the cabinet.

2.5 Connect Electrical Service to Dust Collector.

⚠ WARNING

Shorting electrical components could result in serious electrical shocks, or equipment damage. Electrical power must be locked out and tagged out before performing any electrical work. All electrical work or any work done inside a control panel or junction box must be performed by a qualified electrician, and comply with applicable codes.

All wiring external to the cabinet is provided by the user to comply with local electrical codes.

2.5.1 Standard INEX cabinet and 300 cfm dust collectors are 115-volt single phase. Incoming power to the cabinet is supplied by a U-ground plug; plug it into a 115-volt outlet.

⚠ WARNING

Do not use electrical adaptors that eliminate the ground prong on 115 volt plugs. Doing so could cause electric shock and equipment damage.

2.5.2 Refer to the wiring schematic in Figure 5 and wire the dust collector motor per instruction on the motor data-plate, to the junction box mounted on the cabinet. When wired as noted in Figure 5, the dust collector exhauster motor will start when the cabinet light switch is turned ON, and stop when the switch is turned OFF.

2.5.3 Check Motor Rotation

2.5.3.1 After wiring is completed, observe the warning that follows and check the motor rotation. To check rotation, turn the On-Off switch ON and quickly turn it OFF, causing the motor to rotate slowly. Look through the slots in the motor fan housing where rotation of the fan can easily be observed. Proper rotation is indicated by the arrow on the exhauster housing; the fan should rotate toward the exhauster outlet. If it rotates in reverse, change the wires as noted on the motor plate to reverse rotation.

⚠ WARNING

Do not look into the exhauster outlet while the paddle wheel is turning. Injury to the eye or face could occur from objects being ejected from the exhauster.

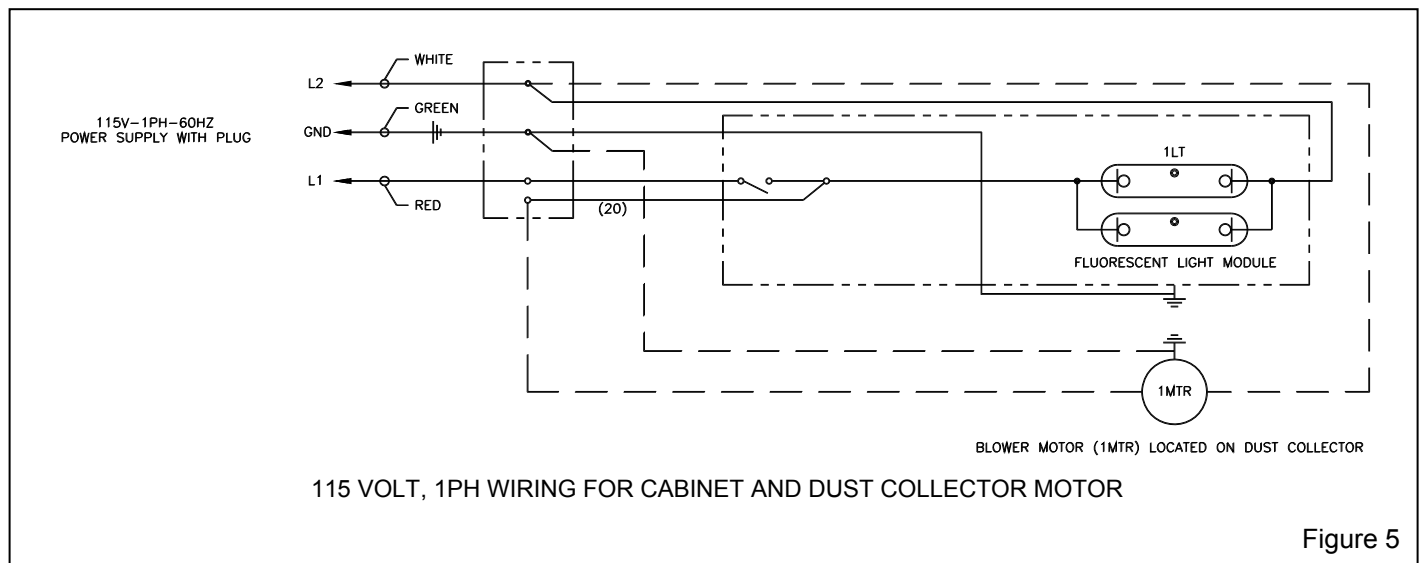

Figure 5

2.6 Final Assembly

2.6.1 Position the foot pedal on the floor at the front of the cabinet.

2.6.2 A package of five view-window cover-lenses is supplied with the cabinet. Install a cover lens per Section 6.3. When the cover lens becomes pitted or frosted, replace it.

3.0 OPERATION

3.1 Media Loading and Unloading

3.1.1 Media Loading: With the exhauster OFF, add clean dry media to the reclaimer hopper by pouring it through the reclaimer door. Do not fill above the cone on the reclaimer. **Do not pour media directly into the cabinet hopper, as overfilling may occur.** Overfilling will result in media carryover to the dust collector and possible blockage in the conveying hose. Refill only after all media has been recovered from the cabinet. The minimum amount of media to charge the system is approximately 10 Lbs.

3.2 Loading and Unloading Parts

WARNING

Use solid fixturing to hold heavy parts in place. Do not remove lift equipment until the part is adequately supported to prevent movement. Moving heavy, unsupported parts may cause them to shift or topple, and cause severe injury. This is especially important with the use of turntables and turntables with tracks.

3.2.1 Load and unload parts through either door.

3.2.2 Parts must be free of oil, water, grease, or other contaminants that will clump media or clog filters.

3.2.3 When blasting small parts or objects having small pieces that could become dislodged and fall off, place an appropriately-sized screen over the grate (or under the grate when frequently blasting small parts) to prevent parts from falling into the hopper.

3.2.4 Close door; the door interlock system will prevent blasting if either door is open.

3.3 Blasting Operation

CAUTION

- **Always close cabinet, reclaimer and dust collector doors before blasting. Keep all doors closed during blasting.**
 - **Always wear blast gloves.**
 - **Avoid pointing the blast nozzle toward the view window.**
 - **After blasting, keep doors closed and exhauster running until the cabinet is clear of all airborne dust.**
 - **Stop blasting immediately if dust leaks are detected.**
-

3.3.1 Slowly open the air valve on the air supply hose to the cabinet. Check for air leaks on the initial start up and periodically thereafter.

3.3.2 Turn ON the lights and exhauster. The ON/OFF switch located on the light shield performs both functions.

3.3.3 Load parts.

3.3.4 Close door; the door interlock system will prevent blasting if either door is open.

3.3.5 Insert hands into gloves.

3.3.6 To blast, hold the gun firmly, point the gun toward the object to be blasted, and apply pressure to the foot pedal; blasting will begin immediately.

WARNING

Shut down the cabinet immediately if dust discharges from the dust collector or cabinet. Check to make sure the dust collector filters are correctly seated and not worn or damaged. Prolonged breathing of any dust could result in serious lung disease or death. Short term ingestion of toxic dust such as lead, poses an immediate danger to health. Toxicity and health risk vary with type of media and dust generated by blasting. Identify all material being removed by blasting, and obtain a safety data sheet (SDS) for the blast media.

3.3.7 Adjust the pilot pressure to the required blast pressure per Section 4.1. The regulator is located on the top, left side of the cabinet.

NOTE: When blasting parts off the grate, use a solid conductive back rest to support the part. Without this assist, especially with longer blasting operations, the operator will tire easily from resisting blast pressure, and static electricity could build up in the ungrounded part and cause static shocks. Whenever possible avoid holding small parts that require blasting into the glove.

3.3.8 If an object should fall through the grate, stop blasting immediately and retrieve it.

3.4 Stop Blasting

3.4.1 To stop blasting, remove pressure from the foot pedal.

3.4.2 Keep doors closed and exhauster running until the cabinet is clear of all airborne dust.

3.4.3 Unload parts. Shut off the air supply valve, drain the air filter, and switch OFF the lights and exhauster.

3.5 Blasting Technique

3.5.1 Blasting technique is similar to spray painting technique. Smooth continuous strokes are most effective. The distance from the part affects size of blast pattern. Under normal conditions, hold the nozzle approximately 3" to 6" from the surface of the part.

4.0 ADJUSTMENTS

4.1 Blasting Pressure

4.1.1 The pilot regulator located on the top, left side of the cabinet, enables the user to adjust blasting pressure to suit the application. The suitable pressure for most purposes is about 80 psi. Lower pressures may be required on delicate substrates, and will reduce media breakdown. Higher pressure may be required for difficult blasting jobs on durable substrates, but will increase media break down. If pressure is too high, suction in media hose will decrease, and if high enough, cause blow-back in the hose. Optimal production can only be achieved when pressure is carefully monitored.

4.1.2 To adjust pressure, unlock the knob by pulling it out as shown in Figure 6, and turn it clockwise to increase pressure or counter-clockwise to decrease pressure. Pressure will usually drop from closed-line pressure when blasting is started. Once operating pressure is set, lock the knob to maintain the setting.

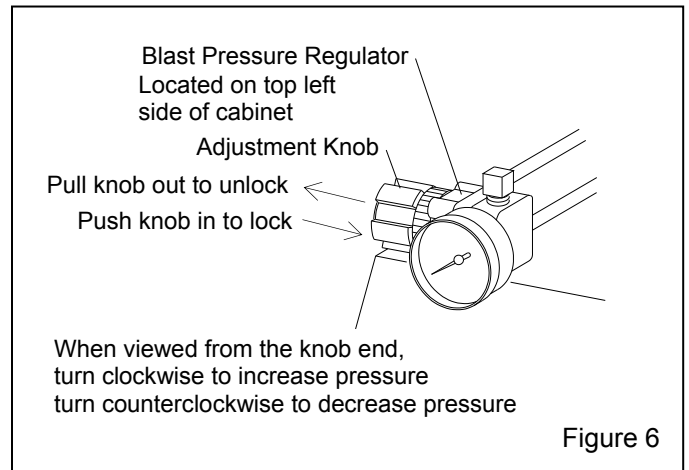

Figure 6

4.2 Air Jet Adjustment, Figure 7

4.2.1 Thread the air jet 4-1/2 to 5 full turns into the gun body. Doing so will leave 3-1/2 to 4 threads exposed past the lock nut. Tighten the lock nut to maintain the setting. Refer to Section 8.3 for optional adjusting tool, which correctly positions the jet.

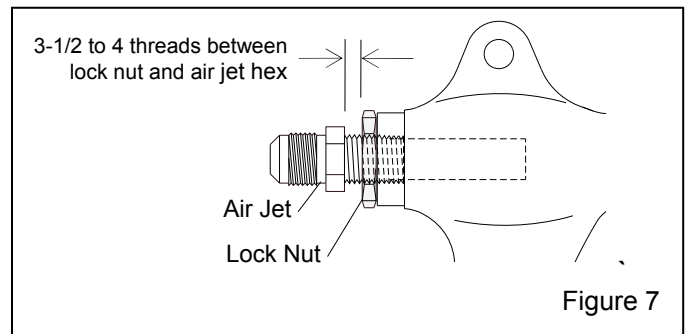

Figure 7

4.3 Media/Air Mixture, Figure 8

4.3.1 Check the media stream for correct media/air mixture; media flow should be smooth and appear as a light mist coming from the nozzle.

4.3.2 If media does not flow smoothly, loosen the locking nut, and adjust the metering screw until the upper holes in the metering stem are closed-off, and the lower holes are fully open, as shown in Figure 8. This adjustment is a starting point.

4.3.3 If pulsation occurs in the media hose, either media is damp and caked, or not enough air is entering the media stream. While blasting, loosen the locking nut and slowly turn the adjusting screw out (counterclockwise when viewed from the top) until the media flows smoothly. Tighten the locking nut finger-tight to maintain the setting.

4.3.4 If media flow is too light, decrease air in the mixture by turning the metering screw in (clockwise when viewed from the top) covering more of the holes so less air

enters the media hose. Tighten the locking nut finger-tight to maintain the setting.

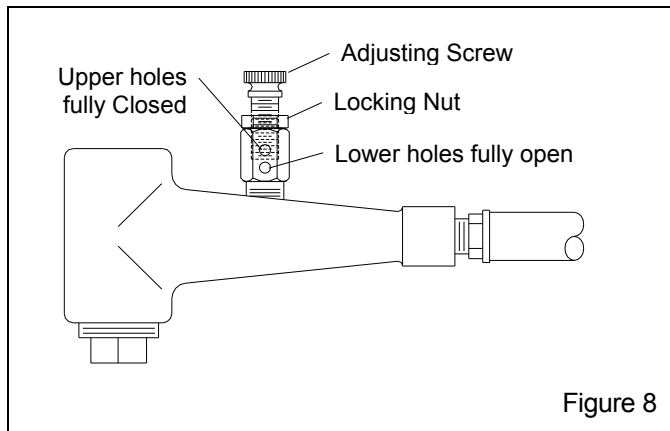

Figure 8

4.4 Reclaimer Static Pressure

4.4.1 Correct static pressure requirements vary with size, weight and type of media.

4.4.2 Adjust static pressure by opening (handle inline with air flow) or closing (handle perpendicular to air flow) the dust collector ventilation-damper. Refer to the dust collector owner’s manual, the damper is located on the CDC-1 dust collector inlet. If the damper is not opened far enough, the reclaimer will not remove fines, resulting in dusty media, poor visibility, and possible media blockage in the conveying hose. If the damper is opened too far, it may cause carryover (usable media carried into the dust collector) and result in excessive media consumption. Open only as far as necessary to obtain a balance of dust removal without media carryover.

4.4.3 A manometer is useful when adjusting or monitoring static pressure. The manometer kit is listed under Optional Accessories in Section 8.1. Refer to Section 4.6 for manometer operation. The following are static pressure starting points for given media. Static pressure may need to be lower with finer media, higher with coarser media. Run the media through several blast cycles allowing the reclaimer to function with these settings. Inspect the media in the reclaimer and fines in the dust collector as noted in Paragraph 4.4.2. Continue adjusting static pressure until optimum media cleaning without carryover is attained.

Glass Bead No. 6 and 7	3" to 3-1/2"
Glass Bead No. 8 to 13	2-1/2 - 3"
Alox. 60 & coarser	4 - 5"
Alox. 80 & finer	2-1/2 - 3"

4.5 Door Interlocks, Figure 9

⚠ WARNING

Never attempt to override the interlock system. Doing so could result in injury from unexpected blasting.

4.5.1 The door interlocks disable the blasting control circuit when the doors are open. To enable blasting, the door interlock switches must be engaged when the doors are closed. The interlocks are set at the factory and do not usually require field adjustment unless parts are replaced. When adjustment is required, proceed as follows.

4.5.2 Close cabinet doors.

4.5.3 Loosen the actuator bracket screws and adjusting screw nut. Move the actuator adjusting bracket up or down, and the adjusting screw sideways, to center the adjusting screw on the over-travel stop. Tighten the bracket screws.

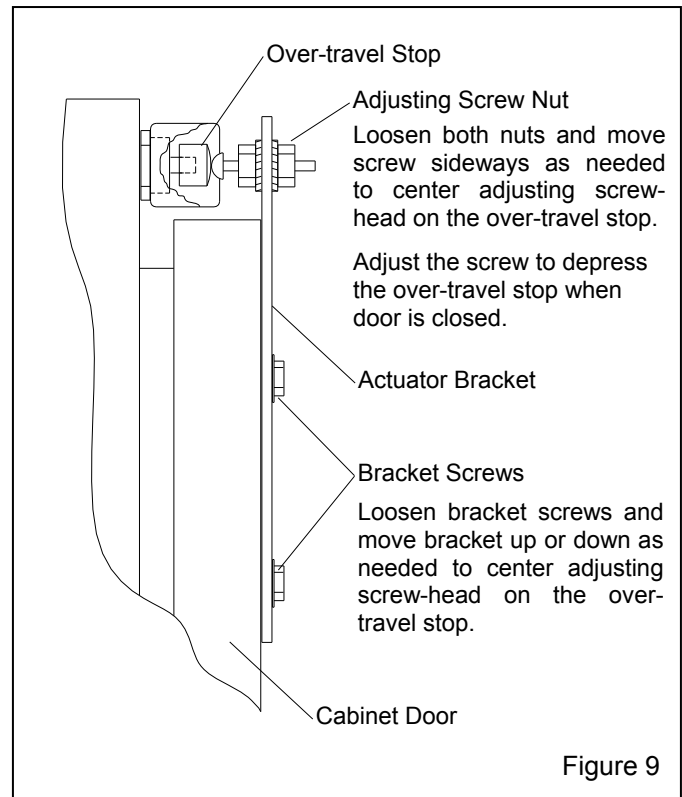

Figure 9

4.5.4 Turn the adjusting screw in or out as required to engage the switch without applying excessive pressure on it. Tighten the adjusting screw nuts.

4.5.5 Test the operation with the doors open and then again closed. Point the nozzle away from the door during the tests, and only open the door enough to disengage

the interlock switch. The interlocks should stop the blasting when the doors are opened, and permit blasting when the doors are closed. NOTE: Negative pressure inside the cabinet may cause the doors to flex inward. Tests should be performed with the exhauster ON.

4.6 Optional Manometer

These instructions show several methods of taking static-pressure readings (negative pressure) on cabinet reclaimers, using a flexible tube manometer. Use the method best suited for the application. The instruction explains the processes for taking periodic readings and shows how to permanently install the manometer for taking frequent readings. Permanent fittings should be installed when rigid ducting is used, or when the manometer installation is permanent. Use silicone sealer or other sealant to seal around the fitting to prevent leaks. The fitting should be capable of being capped when the manometer tube is removed. Capping the fitting will prevent leaks that alter the reclaimer's separation efficiency. The readings are reference points so it doesn't matter where the readings are taken as long as they are always taken at the same location. Taking readings at different locations could produce different results. Static-pressure readings at the door are generally .5" to 1" lower than those taken above the reclaimer.

4.6.1 Refer to directions packed with the manometer for preparation and operating instructions for the manometer.

4.6.2 Connect one end of the 3/16" ID tubing to one of the tubing connectors (elbow) at the top of the manometer by pushing it over the barbed adaptor.

4.6.3 Leave the needle protector on the needle and insert the needle into the other end of the tubing. The ends of the tubing must fit tight on the manometer and needle; leaks will give inaccurate readings.

4.6.4 Open both manometer valves (elbows) per the instructions provided with the manometer.

4.6.5 Magnets on the manometer hold it in position on the reclaimer body. The manometer must be vertically-plumb so the fluid is level on both sides.

4.6.6 Adjust the slide rule to align the zero with the fluid level. Refer to Figure 11

4.6.7 Needle placement: Ref. Figure 10.

4.6.7.1 Taking readings in the flex hose: Remove the needle protector, and insert the needle into the flex hose approximately 8" from the top of the reclaimer.

4.6.7.2 Taking readings at the reclaimer door: Open the reclaimer fill door, remove the needle protector and place the needle so the point is inside the door opening. Carefully close the door on the needle. The side of the needle will embed into the rubber, creating an airtight seal.

4.6.8 Turn the exhauster ON. The negative (static) pressure will move fluid in the tube. **NOTE: Readings must be taken with the cabinet doors open, and with the exhauster running.**

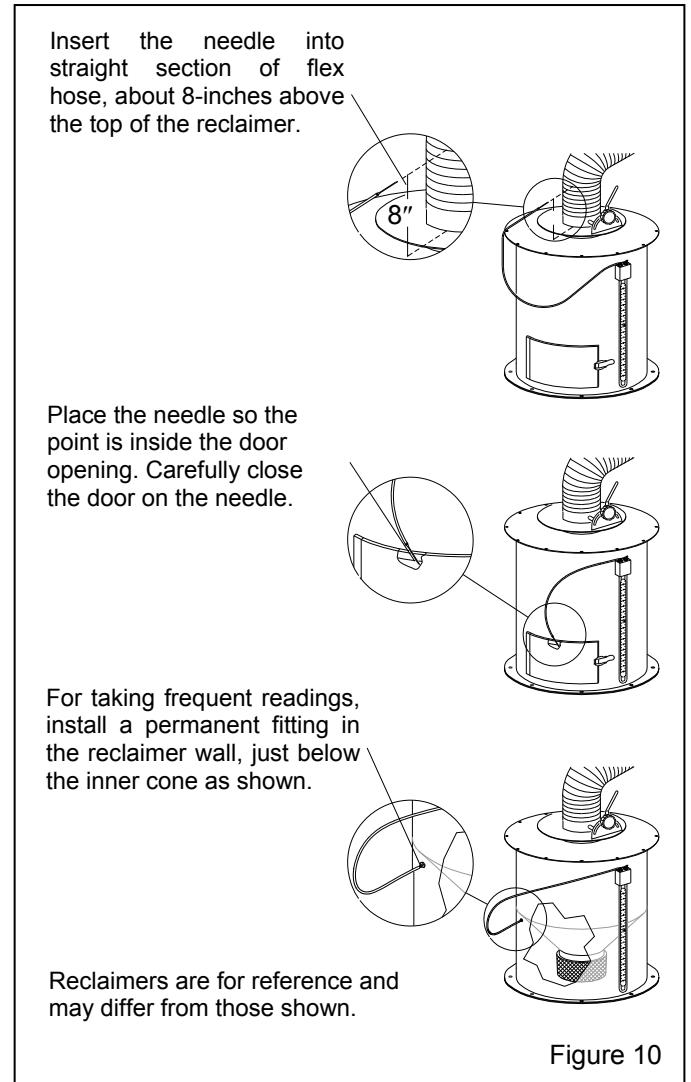

4.6.9 To find the static pressure, add the number of inches the fluid travels up one column to the inches the fluid travels down the other column. Refer to the example in Figure 11.

4.6.10 After the readings are taken, replace the needle protector. Close the manometer valves and store the manometer in the original container in a clean area.

NOTE: If the manometer installation is permanent, the manometer may remain on the reclaimer body after the valves are closed.

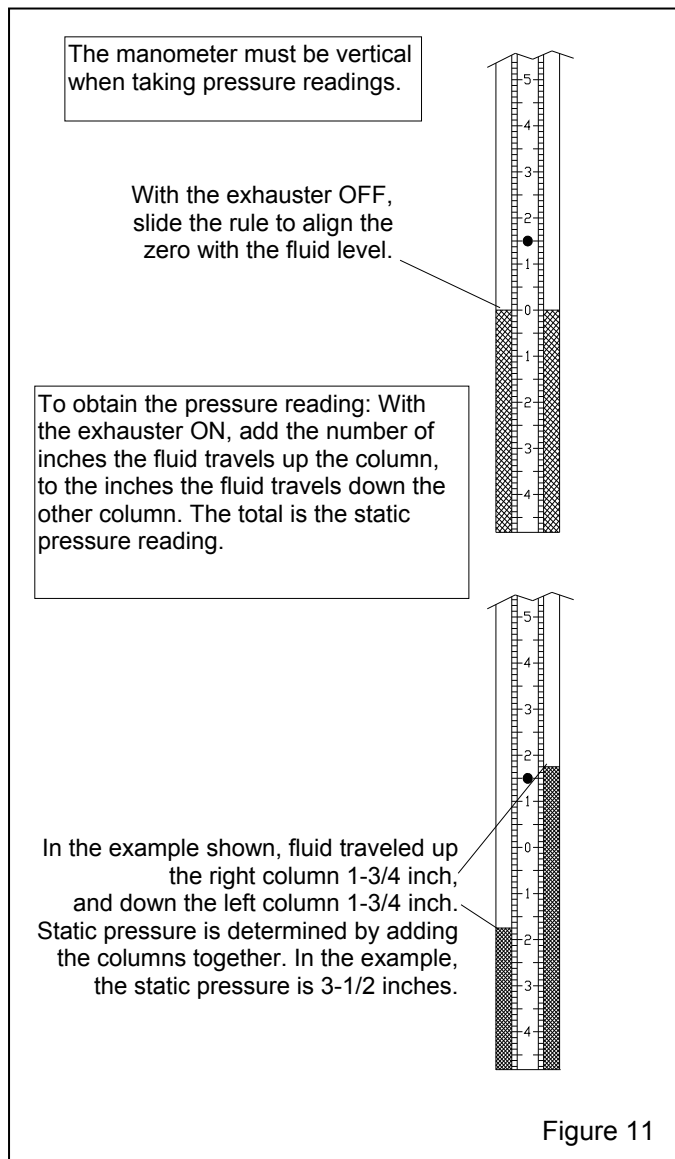

5.0 PREVENTIVE MAINTENANCE

NOTE: To avoid unscheduled downtime, establish an inspection schedule. Inspect all parts subjected to media contact, including; the gun, nozzle, media hose, flex hose, wear plate, plus all items covered in this section.

5.1 Daily

5.1.1 Check media level in reclaimer and refill as necessary.

5.1.2 Check reclaimer debris screen for debris. The screen is accessible through the reclaimer door. With the exhauster OFF, remove the screen and empty it daily or when loading media. Empty the screen more often if part blasted causes excessive debris. Do not operate the machine without the screen in place.

5.1.3 The cabinet is equipped with a manual-drain air filter. Drain the filter at least once a day, and more often if water is present. Moist air inhibits the flow of media. Drain the air line and receiver tank regularly. If the filter does not remove enough moisture to keep media dry and flowing, it may be necessary to install an air dryer or aftercooler in the compressed-air supply line.

5.1.4 Refer to the dust collector owner's manual and empty dust containers. Adjust intervals based on filling rate.

5.1.5 Refer to the dust collector owner's manual and drain the pulse manifold at the end of each shift.

5.1.6 Refer to the CDC-1 dust collector manual for pulsing instructions and pulse the cartridge at least every half hour of blasting and before turning OFF the exhauster. Dusty blasting conditions will require more frequent pulsing. RPC and RPH dust collectors are automatically pulsed at timed intervals.

5.2 Weekly

5.2.1 Inspect view window cover lens, Replace as needed per Section 6.3.

5.2.2 Inspect gloves for wear. The first sign of deterioration may be excessive static shocks. Replace as needed per Section 6.1.

5.2.3 Inspect internal parts of the BNP gun for wear. Replace parts as needed per Section 6.2.

5.2.4 Inspect flex hoses for wear.

5.2.5 During operation, inspect cabinet door seals for media leaks.

5.2.6 Inspect the media hose for thin spots, by pinching it every 6 to 12 inches. Replace the hose when it becomes soft.

5.3 Monthly

5.3.1 Inspect reclaimer wear plate for wear through the inlet adaptor. Replace as necessary per Section 6.5.

5.3.2 Inspect reclaimer door gasket for wear or other damage.

5.4 Dust Collector

Reverse-pulse dust collectors are covered in a separate manual. Refer to Section 1.1.1.

6.0 SERVICE MAINTENANCE

6.1 Gloves

6.1.1 Special static-dissipating gloves are provided for operator comfort. It will be necessary to change gloves periodically as they wear. The first sign of deterioration may be excessive static shocks.

6.1.2 Band-clamp type: Band-clamp type gloves are held in place by metal band-clamps on the inside of the cabinet. To replace, loosen the clamps with a screwdriver, replace the gloves, and tighten the clamps.

6.1.3 Quick-Change type, clampless installation: Quick-change gloves are held in place using spring rings sewn into the attachment end of the glove. To install, insert the glove into the arm port, so one spring is on the inside of the port and the other is on the outside, sandwiching the arm port between both spring rings.

6.2 BNP Gun Assembly, Figure 12

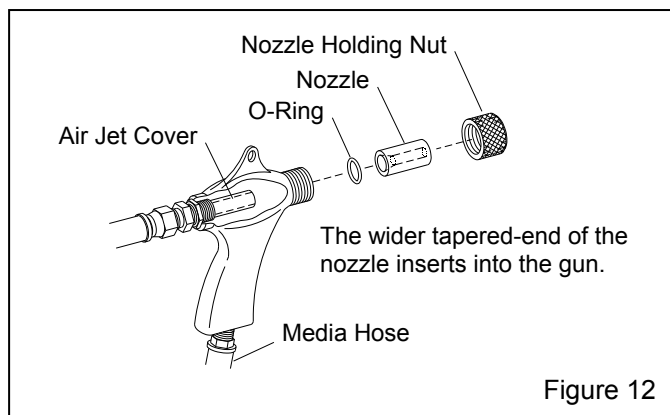

6.2.1 Replace the nozzle when its diameter has increased by 1/16", or when suction diminishes noticeably. To change the nozzle, unscrew the holding nut from the gun end, and pull the nozzle from the gun. Inspect the nozzle o-ring and replace if worn or damaged. Insert a new nozzle, placing the tapered end toward the jet. Screw the holding nut onto the gun.

6.3 View Window Cover Lens

6.3.1 Rapid frosting of the view window can be avoided by directing ricocheting media away from the window, and by installing a cover lens on the inside surface of the window. Using cover lenses prolongs the life of the view window.

6.3.2 To install a cover lens, remove the adhesive backing and apply the lens to the clean, dry, inner surface of the view window. When the cover lens becomes pitted or frosted, peel it off and replace it.

6.4 View Window Replacement

⚠ WARNING

Do not use plate glass for replacement view windows. Plate glass shatters on impact and could cause severe injury. Use only genuine replacement parts.

6.4.1 Swing the light shield up and tie it in place, as shown in Figure 13.

6.4.2 Remove the filler strip by pulling it out of the window molding, as shown in Figure 13.

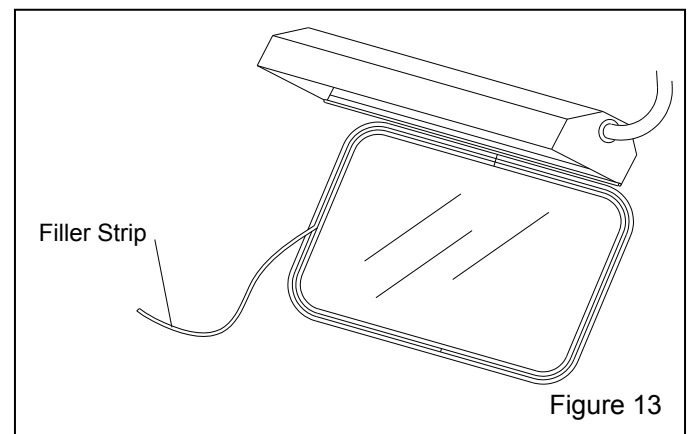

6.4.3 Place an arm into a glove, and push the bottom edge of the window out of the molding, as shown in Figure 14, while supporting the top of the window with the other hand.

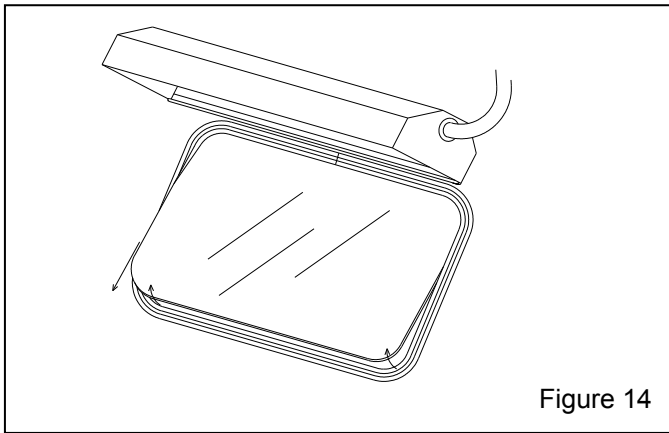

Figure 14

6.4.4 Pull the window downward to remove the window from the molding, as shown in Figure 15.

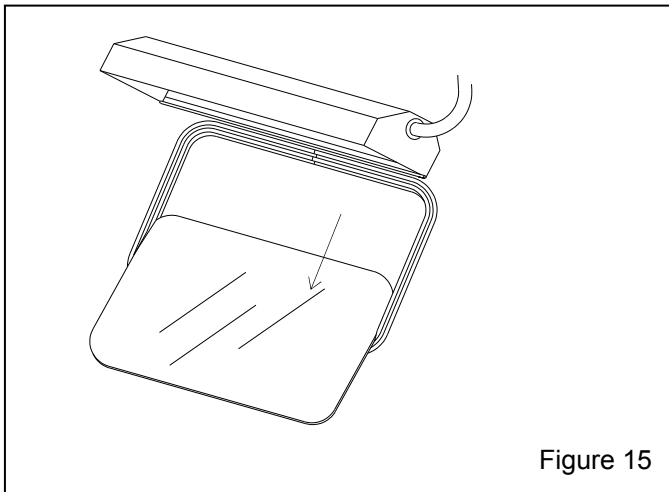

Figure 15

6.4.5 If the window molding needs replacing, replace it in the same manner as the old; the narrow channel fits over the metal edge of the opening, as shown in Figure 16. The molding ends should meet in the middle of the top straight section of the opening. Molding should be compressed so the ends are tightly sealed.

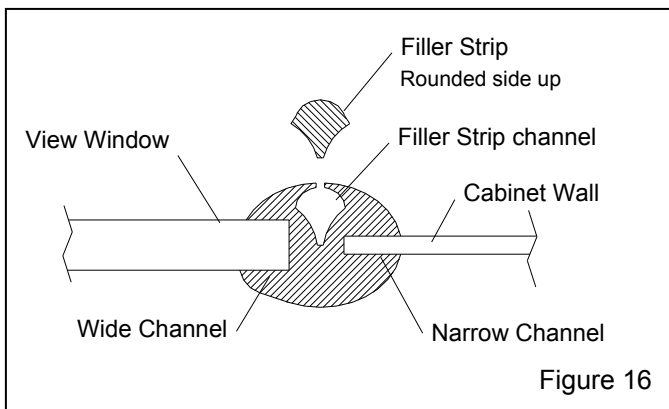

Figure 16

6.4.6 Spray silicone or other lubricant into the window channel (wide channel) on the molding, and slide the window into the channel, as shown in Figure 17. Place an arm into a glove to support the top edge of the bottom side of the window with one hand, while guiding the top edge into the molding with the other.

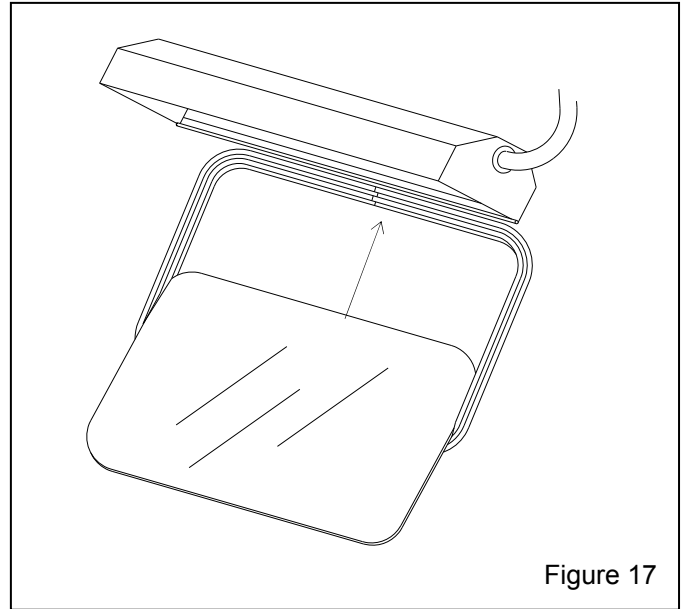

Figure 17

6.4.7 Use a nylon window installation stick, Stock No. 22933, as shown in Figure 18, and work the window channel lip over the glass. When this is done, the window should be entirely within the molding's window channel.

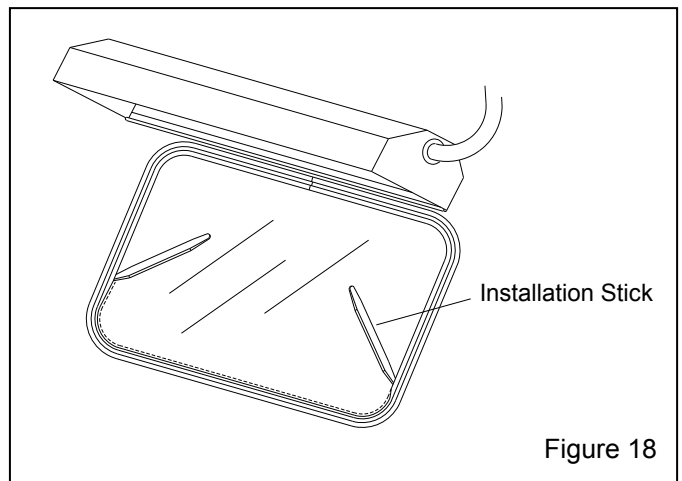

Figure 18

6.4.8 Attach the appropriate tip to the optional installation tool as shown in Figure 19.

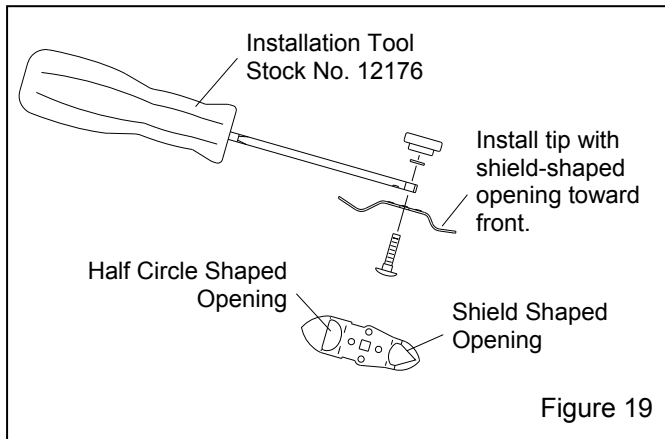

Figure 19

6.4.9. Wipe, or spray the filler strip with silicone or other lubricant to reduce friction. Insert about 2-inches of the strip into the installation tool, as shown in Figure 20.

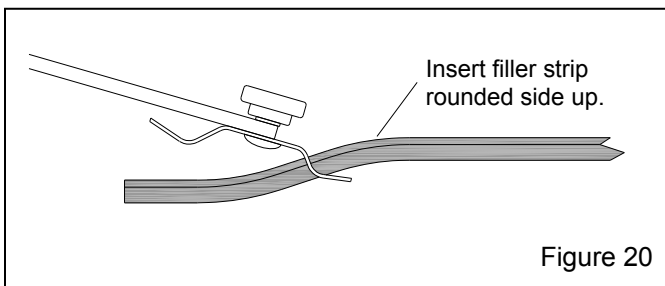

Figure 20

6.4.10 Insert the tool tip and filler strip into the filler strip channel of the molding, at the opposite side of the opening from the window molding ends, as shown in Figure 21. The rounded side of the filler strip faces up.

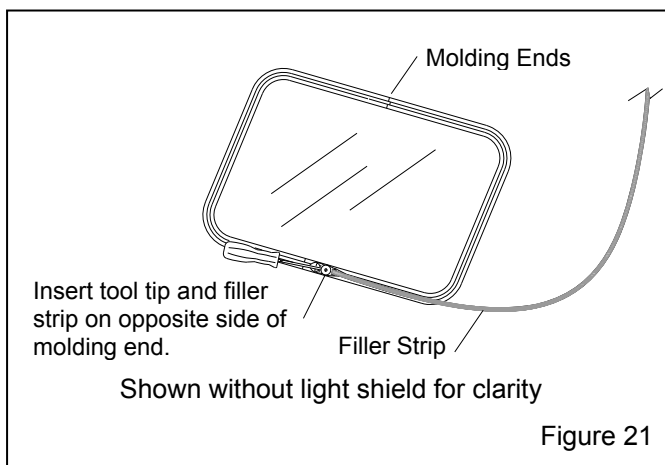

Figure 21

6.4.11 Hold short end of the filler strip and feed the strip into the channel by pushing the tool through the top of the channel, as shown in Figure 21. Rotate the tip as needed, if the light shield or other obstructions interfere with moving the installation tool around turns. Continue

feeding the strip into the channel, as shown in figure 22 until the end of the strip is in place at the starting point.

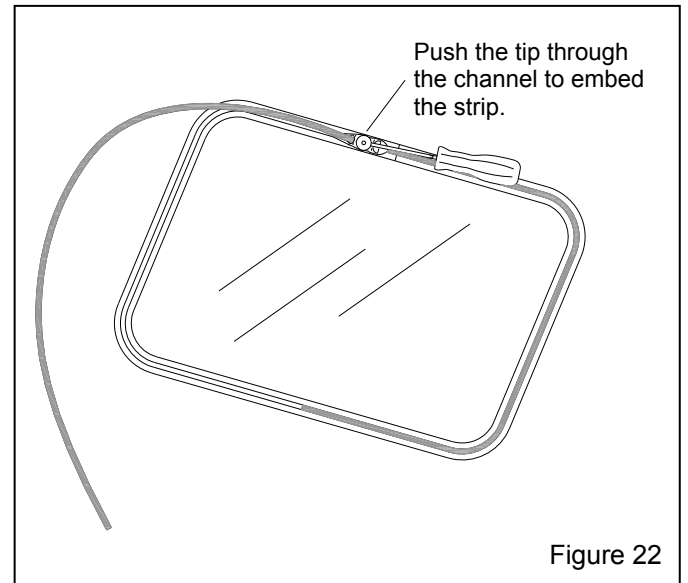

Figure 22

6.4.12 Use the window stick to push the filler strip into the molding at any spot the strip is not fully seated. Place the light shield in its normal position.

6.5 Reclaimer Wear plate Replacement

6.5.1 Remove the reclaimer inlet adaptor and old wear plate. The wear plate is held in place by screws attached from the outside of the reclaimer; remove the screws and pull out the wear plate from the reclaimer inlet.

6.5.2 Angle the new wear plate into the reclaimer inlet until it is in position with the straight end at the reclaimer inlet. Insert a board or similar object for leverage and pry the wear plate against the inner wall of the reclaimer. While forcing the wear plate against the reclaimer wall, install sheet metal screws through the old screw holes to secure. Caulk seams between the wear plate and reclaimer to prevent rapid wear in those areas.

6.6 CDC-1 Dust Collector

6.6.1 Refer to the CDC-1 dust collector manual, stock no. 28225, for maintenance of the collector.

7.0 TROUBLESHOOTING

WARNING

To avoid serious injury, observe the following when troubleshooting.

- Turn OFF the air, and lockout and tagout the air supply.
 - If checking the controls requires air, always enlist the aid of another person to: Hold the blast gun securely. Operate the foot pedal.
 - Never bypass the foot pedal or wedge it in the operating position.
 - Never override the door interlock system.
-

7.1 Poor visibility

7.1.1 Dirty filter cartridge. Pulse cartridge and empty dust container regularly.

7.1.2 Exhauster motor not operating. Check voltage to motor and motor wiring.

7.1.3 Check rotation of exhauster motor; the motor should rotate as indicated by the arrow on the housing. If it does not rotate in the proper direction, **lockout and tagout power** and switch the motor leads as shown on the motor plate. Refer to Section 2.5.4.

7.1.4 Using friable media that rapidly breaks down, or using media that is too fine or worn out.

7.1.5 Dust collector damper closed too far restricting air movement in cabinet. Adjust static pressure per Section 4.4.

7.1.6 Blocked air inlet duct. Blockage in the air intake ducts restricts incoming air and reduces air movement in the cabinet.

7.1.7 Reclaimer door open.

7.1.8 Hole worn in flex hose between cabinet hopper and reclaimer inlet or between the reclaimer and dust collector. Replace hose and route it with as few bends as possible to prevent wear.

7.1.9 Obstruction in flex hose between the cabinet hopper and reclaimer inlet.

7.2 Abnormally high media consumption

7.2.1 Door on reclaimer open or worn door gasket. Air entering the reclaimer around the door will cause media carryover to the dust collector. DO NOT operate unless all doors are closed.

7.2.2 Dust collector damper open too far. Adjust static pressure per Section 4.4.

7.2.3 Media may be too fine or worn-out.

7.2.4 Using friable media that rapidly breaks down.

7.2.5 Blast pressure too high for the media, causing media to break down.

7.2.6 Hole worn in reclaimer, or leak in reclaimer seams. Check entire reclaimer for negative-pressure leaks.

7.2.7 If using media finer than 180-mesh, the reclaimer inlet baffle may need to be removed. Refer to Section 1.7.6.

7.3 Reduction in blast cleaning rate

7.3.1 Low media level reducing media flow. Check media level; add media or change media as needed.

7.3.2 Media/air mixture out of adjustment. Adjust metering valve per Section 4.3.

7.3.3 Reduced air pressure. This may be caused by a malfunctioning regulator, a dirty filter element in the air filter, partially-closed air valve, leaking air line, or other air tools in use.

7.3.4 Blockage in media hose or gun. Blockage may occur as a result of a damaged or missing reclaimer screen or heavy media flow. Inspect reclaimer screen and adjust media flow per Section 4.3.

7.3.5 Worn gun parts such as nozzle or air jet. Inspect gun and replace all worn parts.

7.3.6 Worn media hose. Check hose for leaks and soft spots. Replace worn or damaged hose.

7.3.7 Air jet in gun out of adjustment. Check adjustment per Section 4.2.

7.3.8 Moist media. Frequent bridging or blockage in the area of the metering valve can be caused by moisture. Refer to Section 7.5.

7.4 Plugged nozzle

7.4.1 A damaged or missing reclaimer screen will allow large particles to pass and block the nozzle. Replace or reinstall as necessary.

7.4.2 Media mixture too rich. Adjust media/air mixture per Section 4.3.

7.5 Media bridging

7.5.1 Frequent bridging or blockage in the media metering valve can be caused by damp media. Media becomes damp by blasting parts that are slightly oily, from moisture in the compressed-air line, or from absorption from ambient air.

7.5.2 To avoid contaminating media from the workpiece, all parts put into the cabinet should be clean and dry. If parts are oily or greasy, degrease and dry them prior to blasting.

7.5.3 Moist compressed air may be due to a faulty compressor that overheats, or pumps oil or moisture into the air line, too long an air line permitting moisture to condense on the inside, and from high humidity. Drain the air filter and receiver tank regularly. Ongoing problems with moist air may require the installation of an air dryer or aftercooler in the air supply line.

7.5.4 Absorption. Some media types tend to absorb moisture from the air, especially fine-mesh media in areas of high humidity. Empty the media and store it in an airtight container when cabinet is not in use.

7.5.5 A vibrator attached to the reclaimer cone or media metering valve may help to prevent bridging of fine-mesh media. NOTE: To avoid the possibility of compressing media, a vibrator should be setup to start only when the foot pedal is pressed.

7.6 Blasting does not begin when the foot pedal is pressed.

7.6.1 Door interlocks not engaging. Check adjustment per Section 4.5.

7.6.2 Blocked or leaking control lines. Check all urethane tubing for blockage or leaks.

7.6.3 Foot pedal valve malfunction. Check foot pedal alignment, and inlet and outlet lines for pressure.

7.6.4 Make sure lines are not reversed on the foot pedal or pilot regulator. Refer to the schematic in Figure 29.

7.6.5 Pressure regulator may be set too low or OFF. Check pressure on pilot regulator.

7.6.6 Make sure that the air compressor is operating and air supply valves are open.

7.6.7 Check the nozzle to see if it is plugged. Refer to Section 7.4.

7.7 Blasting continues when the foot pedal is released

7.7.1 Make sure the 3-way valve in the foot pedal exhausts air when the pedal is released. If it does not exhaust, check the inbound air line for blockage, if no blockage, replace the valve.

7.8 Blockage in Media Hose

7.8.1 Media obstructions. Usually caused when the media mixture is too rich. Adjust media/air mixture per Section 4.3.

7.8.2 Wet or damp media. See Section 7.5.

7.9 Media surge

7.9.1 Heavy media flow. Adjust per Section 4.3.

7.10 Poor suction in media hose

7.10.1 Refer to the tables in Paragraphs 1.8.1 and 2.3.2 and make sure cfm and air hose requirements are met.

7.10.2 Air jet needs adjustment. Check adjustment per Section 4.2.

7.10.3 Nozzle is worn. Replace if worn 1/16" or more.

7.10.4 Blockage in media hose or nozzle. Refer to Sections 7.4 and 7.8.

7.10.5 Air jet and nozzle combination may be wrong. Refer to the table in Paragraph 1.8.1.

7.10.6 Air jet sleeve extends past end of air jet. Cut the sleeve to align with the air jet.

7.10.7 Blast pressure too high, refer to Section 4.1.

7.10.8 Nozzle inserted backward; the tapered end of the nozzle should face toward the air jet.

7.11 Air only (no abrasive) from nozzle

7.11.1 Low media level in reclaimer. Check media level and replenish as needed.

7.11.2 Make sure the air hose and media hose are not reversed; the green air hose attaches to the back of the gun and the clear media hose attaches to the bottom of the gun's grip. Refer to Figure 25.

7.12 Blow-back through media hose

7.12.1 Blockage in nozzle. Remove the nozzle and check blockage.

7.12.2 Air jet may be too large for nozzle. Refer to the table in Paragraph 1.8.1.

7.12.3 Blast pressure too high, refer to Section 4.1.

7.13 Media buildup in cabinet hopper, does not convey to reclaimer

NOTE: Do not pour media directly into the cabinet hopper, as overfilling may occur. Overfilling will result in media carryover to the dust collector and possible blockage in the conveying hose.

7.13.1 Exhauster motor rotating backwards. The motor should rotate as indicated by the arrow on the exhauster housing. If it does not rotate in the proper direction, **lockout** and **tagout** electrical power and switch the motor leads as shown on the motor plate. Refer to the system's wiring schematic. Refer to Sections 2.5.4.

7.13.2 Dust collector ventilation damper closed too far restricting air movement through cabinet. Adjust static pressure per Section 4.4.

7.13.3 Dust collector filter cartridge blinded. Refer to the CDC-1 dust collector manual, stock no. 28225.

7.13.4 Hole worn in flex hose between cabinet hopper and reclaimer inlet or between the reclaimer outlet and dust collector inlet. Replace hoses and route them with as few bends as possible to prevent wear.

7.13.5 Reclaimer door open. DO NOT operate unless door is closed.

7.13.6 Obstruction flex hose. Remove hoses and check for blockage.

7.14 Static shocks

7.14.1 Cabinet and/or operator not grounded. Abrasive blasting generates static electricity. The cabinet must be earth-grounded to prevent static buildup. Refer to Section 2.4. If shocks persist, the operator may be building up static. Attach a small ground wire, such as a wrist strap, from the operator to the cabinet.

7.14.2 Gloves wearing thin. Inspect gloves and replace them as needed.

7.14.3 Avoid holding parts off the grate. Static will buildup in the part if not dissipated through the metal cabinet.

7.15 Dust leaking from cabinet

7.15.1 Refer to Section 7.13.

7.16 Dust leaking from dust collector

7.16.1 Damaged or loose filters cartridge. Inspect filter and replace as needed.

7.16.2 Refer to the CDC-1 dust collector owner's manual, stock no. 28225, for operation of the dust collector.

8.0 ACCESSORIES AND REPLACEMENT PARTS

8.1 Optional Accessories

Conversion kits, push-thru reclaimer to pull-thru

Description	Stock No.
Conversion kit to convert push-thru reclaimer to pull-thru. to convert from dry filter to CDC-1 dust collector. Kit includes outlet adaptor pipe, gasket, and fasteners. for 300 cfm reclaimer	28962

Description	Stock No.
Tungsten carbide nozzle	
No. 5	13118
Boron carbide nozzle	
No. 5	11935
No. 6	11936

Wide spray nozzle	
Tungsten carbide	
No. 6	11947
Boron carbide	
No. 6	11934

NOTE: Wide spray nozzles require the following accessories:

Wide spray nozzle nut	11916
Wide spray retaining ring	12038
Wide spray nozzle guard	12295

Lock pins (pkg of 25) for twist-on hose couplings	11203
Manometer kit	12528
Armrest assembly	24900
Anti-fatigue floor-mat, for front of cabinet	24744

Optional Extension Nozzles, Figure 23

Item	Description	Stock No.
1.	3" Straight extension nozzle	
	No. 5, 5/16" orifice	11921
	No. 6, 3/8" orifice	11922
	No. 7, 7/16" orifice	11923
2.	6" Straight extension nozzle	
	No. 5, 5/16" orifice	11927
	No. 6, 3/8" orifice	11928
	No. 7, 7/16" orifice	11929
3.	9" Straight extension nozzle	
	No. 5, 5/16" orifice	11924
	No. 6, 3/8" orifice	11925
	No. 7, 7/16" orifice	11926
4.	Side-angle extension nozzle assemblies with No. 5 orifice, includes 5, 6, 7, and 8	
	4" long assembly	21311
	6" long assembly	12374
	9" long assembly	12373
5.	Side angle extension nozzle casing	
	4" long casing	11943
	6" long casing	11940
	9" long casing	11939
6.	Tip, side-angle extension	12173
7.	Snap ring, side-angle extension	12040
8.	O-ring, side-angle extension	08977

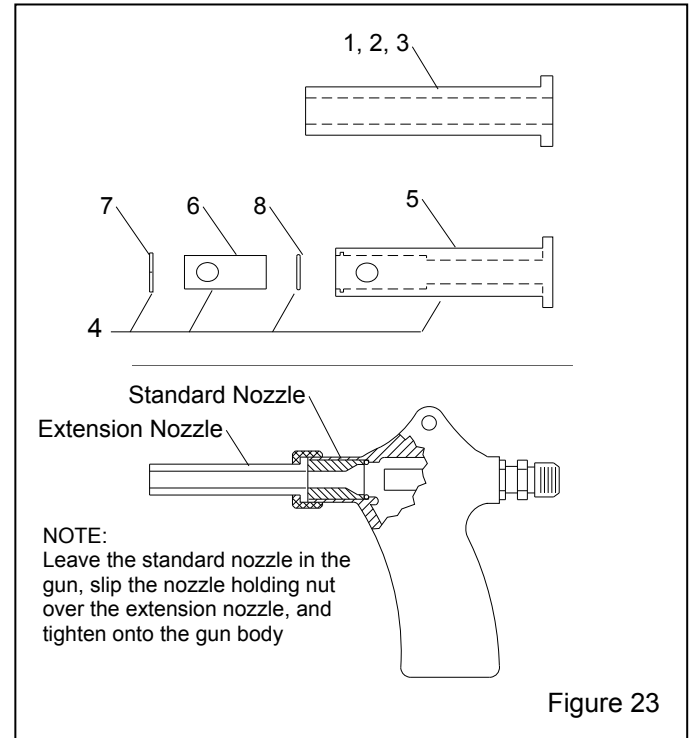
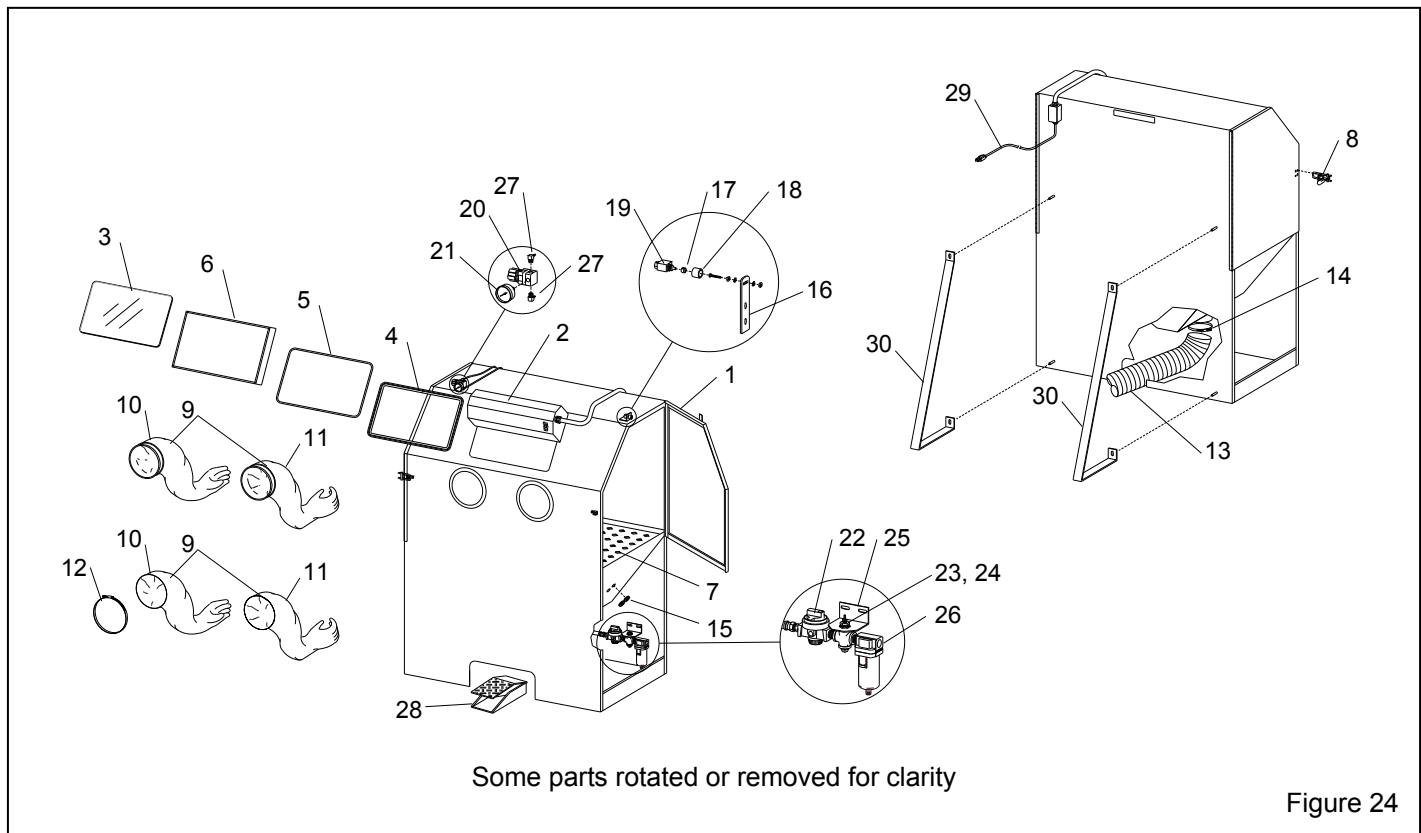

Figure 23

8.2 Cabinet Replacement Parts, Figure 24

Item	Description	Stock No.
1.	Gasket, door, adhesive-backed, per foot, 10-ft. per door, specify feet required	00187
2.	Light shield assembly with switch	11601
3.	Window glass, 12.5" x 19.5"	12212
4.	Gasket, window molding, 6 ft. required	12435
5.	Filler strip, window molding, 6 ft. required	12436
6.	Cover lens, pkg. of 5	06190
7.	Grate, 3048	10761
8.	Latch assembly, door	10908
9.	Glove set	
	Band-clamp attachment	11215
	Quick-Change (clampless attachment)	28820
10.	Glove, left hand only	
	Band-clamp attachment	12710
	Quick-Change (clampless attachment)	28638
11.	Glove, right hand only	
	Band-clamp attachment	12711
	Quick-Change (clampless attachment)	28639

12.	Clamp, glove	11576
13.	Hose, 4" ID light-lined flex, 7 ft. required	12466
14.	Clamp, 4" flex hose	11577
15.	Grommet, media/air hose	11798
16.	Actuator, door interlock	19152
17.	Over-travel stop, door interlock	20004
18.	Detent sleeve, door interlock	15042
19.	Air valve, 3 way, door interlock	12202
20.	Regulator, 1/8" NPT pilot	12715
21.	Gauge, pressure, 1/8" NPT cbm	01908
22.	Regulator, 1/2" pilot operated	11345
23.	Bushing 1/2"x 1/8" NPT	11350
24.	Bushing 1/4"x 1/8" NPT	02010
25.	Bracket, mounting	19231
26.	Filter, 1/2" air	01308
27.	Fitting, 1/8" NPT elbow x 1/8" barb	11733
28.	Foot pedal assembly, less tubing	20483
29.	Cord with plug, 115 volt	11669
30.	Support bracket, each	24757



8.3 BNP Gun and Feed Assembly, Figure 25

Item	Description	Stock No.
(-)	BNP Gun assemblies less nozzle, includes items 1 (brass) through 7	
	No. 4 Gun	12301
	No. 5 Gun	12302
	No. 6 Gun	12303
	No. 7 Gun	12304
	No. 8 Gun	12305
1.	Nut, nozzle holding	
	Standard, knurled brass	11914
	Urethane covered	11574
2.	O-ring	08975
3.	Gun body	11802
4.	Lock nut, air jet	11913
5.	Rubber sleeve	12097
6.	Air jet assembly w/ Item 5	
	No. 4	12342
	No. 5	12343
	No. 6	12344
	No. 7	12345
	No. 8	12346
7.	Fitting, hose, 3/8" NPT x 1/2" barb	06369
8.	Hose end, 1/2" barb x 1/2" fem. swivel	15002

9.	Nozzle, ceramic	
	No. 5	11930
	No. 6	11931
	No. 7	11932
	Nozzle, boron carbide	
	No. 5	11935
	No. 6	11936
	No. 7	11937
	No. 8	12894
	Nozzle, tungsten carbide	
	No. 5	13118
	No. 7	12882
	No. 8	11942
10.	Hose, 1/2" air, six feet required	12472
11.	Hose, media, clear urethane, six feet required	12476
12.	Wide spray nozzle	
	Tungsten carbide, No. 6	11947
	Boron carbide	
	No. 6	11934
	No. 8	11944
13.	Wide spray nozzle nut	
	Knurled brass	11916
	Urethane covered	12906
14.	Wide spray retaining ring	12038
15.	Wide spray nozzle guard	12295
16.	Adjusting tool, air jet	19041

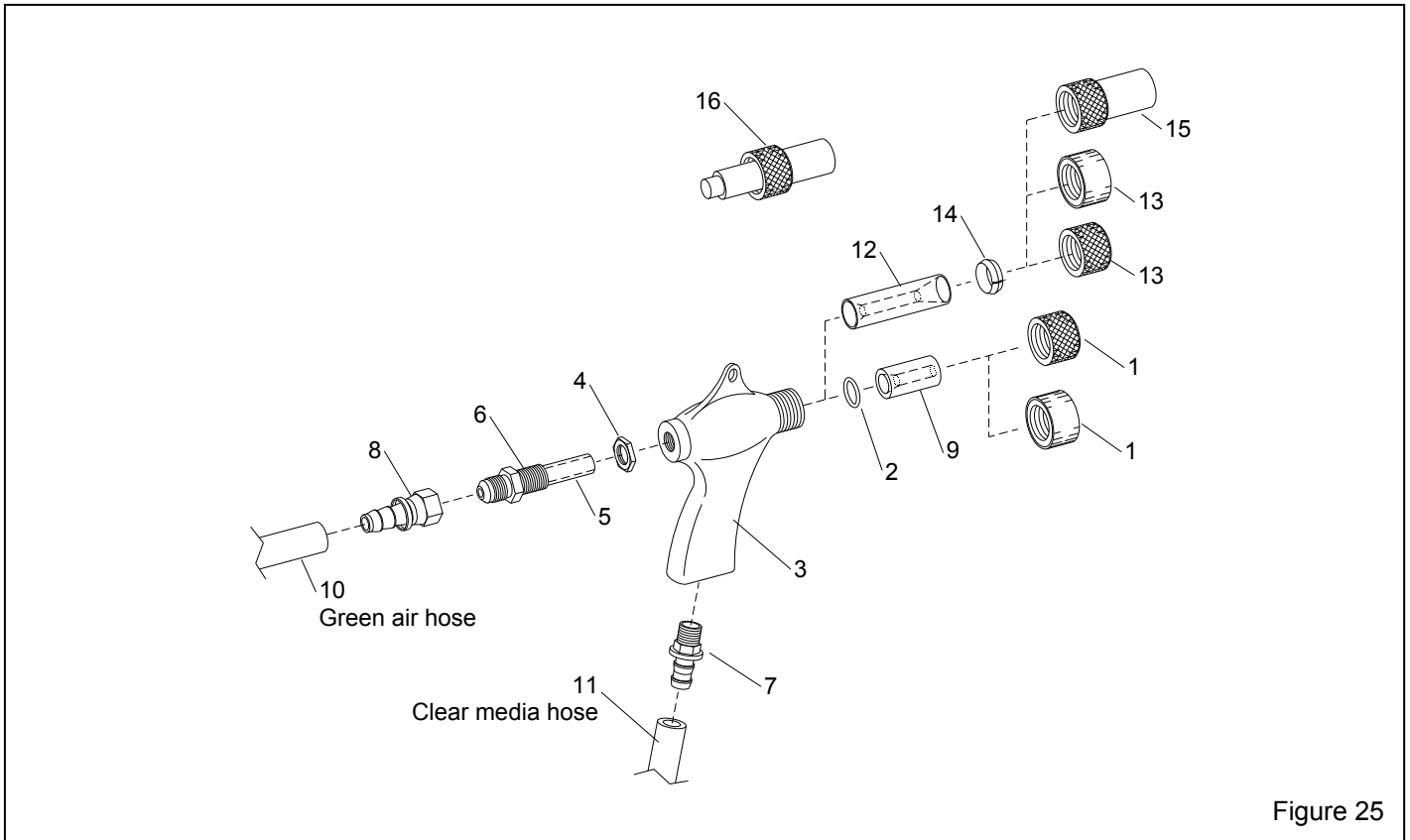

Figure 25

8.4 Foot Pedal Assembly, Figure 26

Item	Description	Stock No.
(-)	Foot pedal assembly, less tubing	20483
1.	Foot pedal casting set, top and base	28379
2.	Valve, 10-32, 3 way n/c	20026
3.	Drive pin, grooved	20109
4.	Screw, sh 1/4 NF x 3/4"	03086
5.	Screw, 10-32 x 1/2" fh	19571
6.	Adaptor, 10-32 thrd. x 1/8 barb	11731
7.	Spring, 1-1/4" x 3-1/2"	20121
8.	Screw, 8-32 x 3/8" thread cutting	11389
9.	Bumper, rubber (feet)	21522

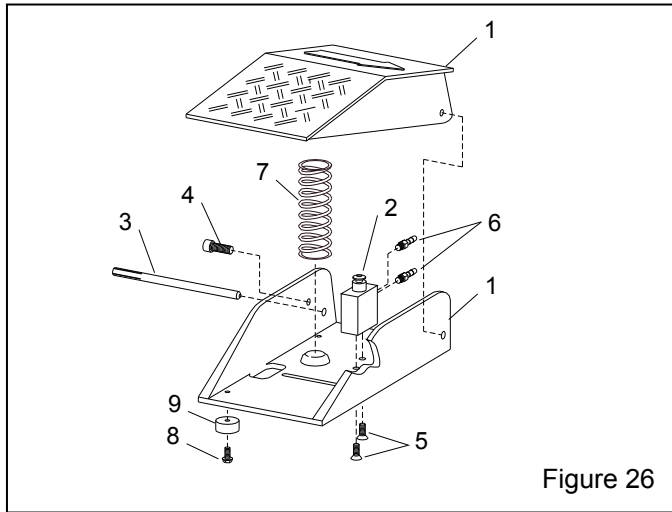

Figure 26

8.5 Metering Valve Assembly, Figure 27

Item	Description	Stock No.
(-)	Metering valve assembly, items 2 thru 7	12417
1.	Metering stem assembly	23889
2.	Stem, metering adjusting	23097
3.	Screw, adjusting	23098
4.	Nut, adjusting stem lock	23099
5.	Body, metering valve	11532
6.	Fitting, hose, 3/8" NPT x 1/2" barb	06369
7.	Plug, metering valve	12011

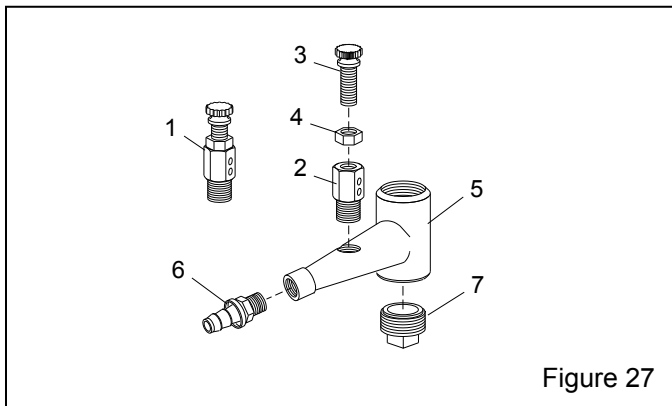

Figure 27

8.6 Light Shield Assembly, Figure 28

Item	Description	Stock No.
(-)	Light shield assembly with switch	11601
1.	Ballast	11553
2.	Lamp holder	11843
3.	Starter holder	12163
4.	Starter	12156
5.	Lamp, 15 watt	11872
6.	Connector, poly straight	02929
7.	Base plate, light shield	11561
8.	Trim edge, 2 ft. required	18460
9.	Switch, on-off	12127

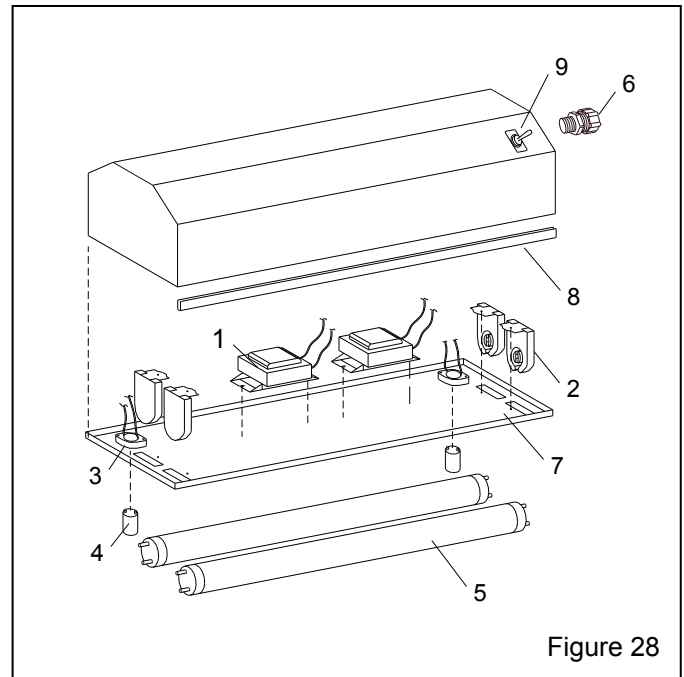

Figure 28

8.7 Cabinet Plumbing Assembly, Figure 29

Item	Description	Stock No.
1.	Valve, 3 way	12202
2.	Adaptor, 1/8" NPT x 1/8" barb	11732
3.	Tubing, 1/8" urethane, spec ft. required ...	12475
4.	Tubing, twin urethane, spec ft. required ...	19577
5.	Foot pedal assembly, less tubing	20483
6.	Fitting, 1/8" NPT elbow x 1/8" barb	11733
7.	Bushing 1/2"x 1/8" NPT	11350
8.	Bushing 1/4"x 1/8" NPT	02010
9.	Bracket, mounting	19231
10.	Filter, 1/2" air	01308
11.	Adaptor, 1/2" NPT x 1/2" flare	11351

12.	Hose end, 1/2" barb x 1/2" fem. swivel	15002
13.	Hose end, 1/2" barb x 3/8" male NPT	06369
14.	Metering valve assembly	12417
15.	Air hose, 1/2", spec ft. required	12472
16.	Gun assembly, BNP No. 5	12302
17.	Hose, clear urethane, spec ft. required ...	12476
18.	Regulator, 1/2" pilot operated	11345
19.	Regulator, 1/8" pilot	12715
20.	Gauge, pressure, 1/8" NPT cbm	01908
21.	Nipple, 1/2" x 2	01734
22.	Cross, 1/2" NPT	10254
23.	Lock nut, 1/2"	12713
24.	Plug 1/2" NPT	01759

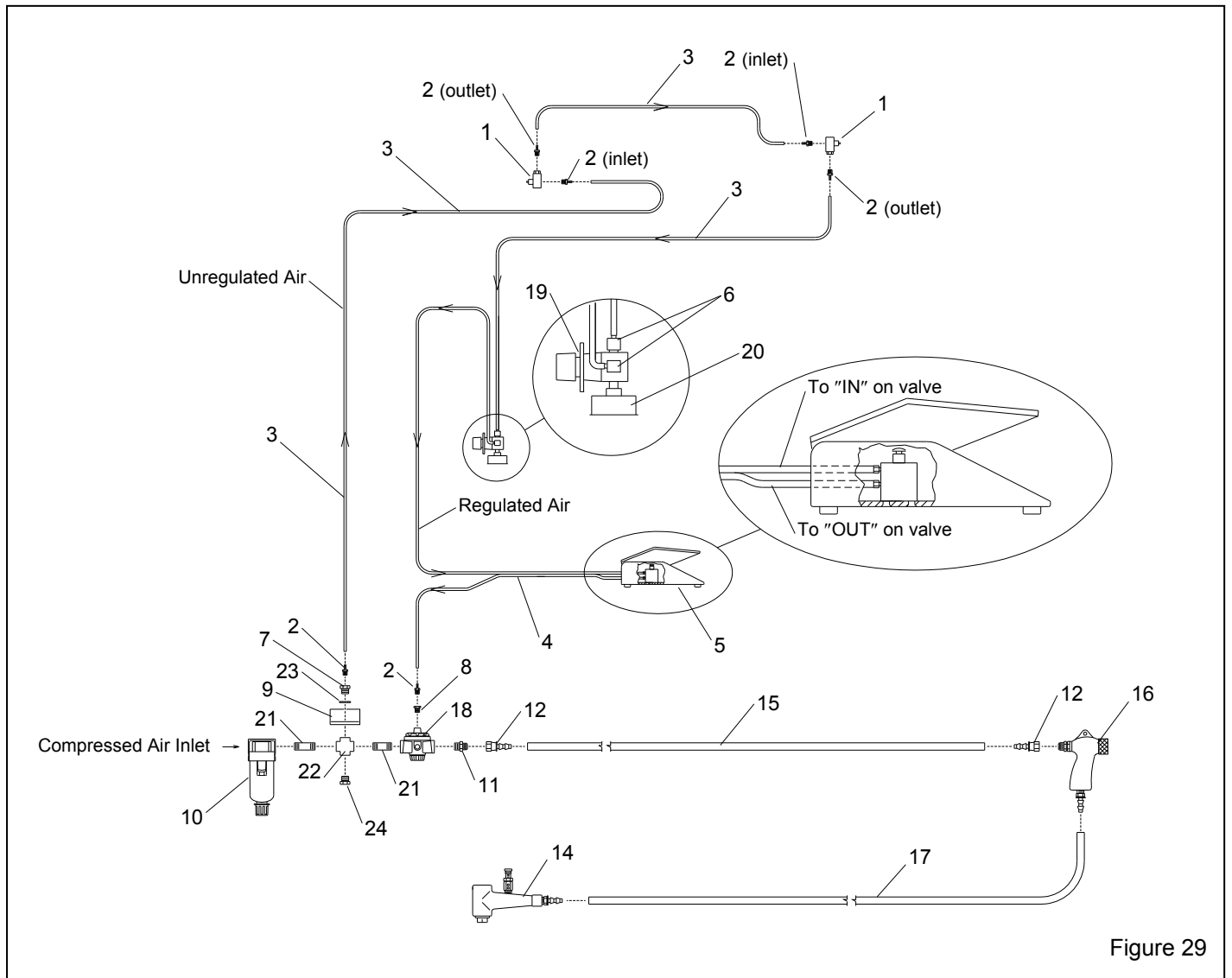

Figure 29

8.8 Reclaimer

Item Description Stock No.

Replacement reclaimer is pull-thru type for use with a reverse-pulse dust collector it includes the hose inlet, screen and wear plate. It does not include metering valve flex hoses, hose clamps, or mounting brackets. Order separately when needed.

Description Stock No.

300 cfm reclaimer w/outlet pipe adaptor28965

8.9 300 CFM Reclaimer Replacement Parts, Figure 30

Item Description Stock No.

- 1. Gasket, 5/16" x 1" adhesive-backed, per foot, specify feet required00187
- 2. Screen assembly, 8-mesh21265

- 3. Gasket, door 11745
- 4. Inlet pipe adaptor 300 cfm, 4" 12365
- 5. Gasket, inlet adaptor 300 cfm 11746
- 6. Wear plate, rubber-lined w/mounting screws 300 cfm 14060
- 7. Adaptor, outlet pipe 300 cfm 18475
- 8. Spring latch assembly 12263
- 9. Door assembly, w/gasket and latch 14271
- *10. Clamp, hose 4-1/2", for 4" ID hose, 300 cfm 11577
- *11. Hose, light-lined flex, per foot, specify length 4" ID for 300 cfm 12466
- *12. Hose, unlined flex, per foot, specify length 5" ID for 300 cfm 12449
- *13. Clamp, hose 5-1/2", for 5" ID hose, 300 cfm 11578
- *14. Bracket, reclaimer mount, each 12847
- *15. Metering valve assembly 12417

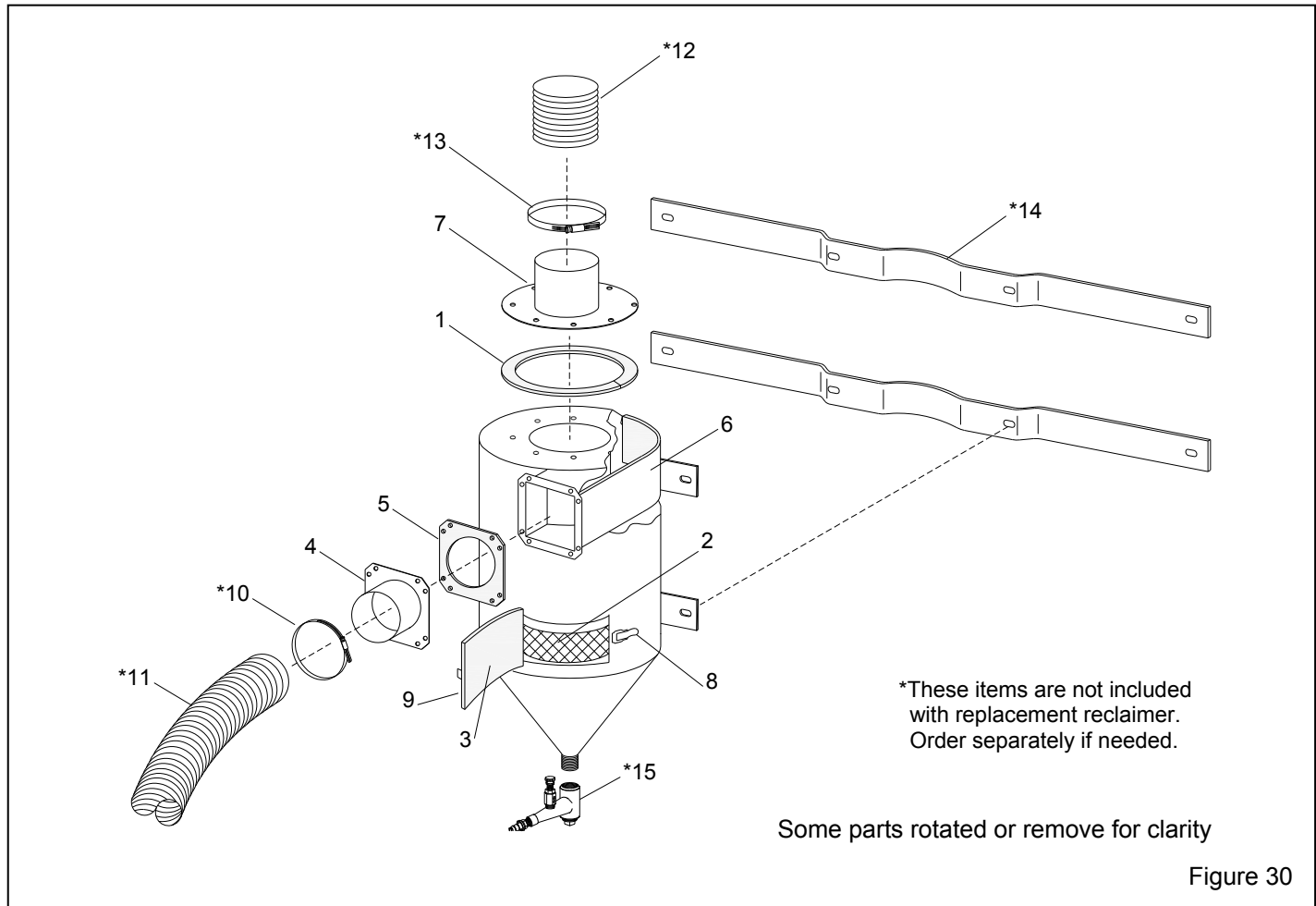

Figure 30