

RPH Reverse-Pulse Dust Collectors

Models RPH-2, 3, 4, 6, and 8

O. M. 21449

DATE OF ISSUE: 03/95
REVISION: D, 08/17

NOTICE TO PURCHASERS AND USERS OF OUR PRODUCTS AND THIS INFORMATIONAL MATERIAL

Clemco proudly provides products for the abrasive blast industry and is confident that industry professionals will use their knowledge and expertise for the safe and efficient use of these products.

The products described in this material, and the information relating to these products, are intended for knowledgeable, experienced users. It is the responsibility of the user to insure that proper training of operators has been performed and a safe work environment is provided.

No representation is intended or made as to: the suitability of the products described here for any purpose or application, or to the efficiency, production rate, or useful life of these products. All estimates regarding production rates or finishes are the responsibility of the user and must be derived solely from the user's experience and expertise, not from information contained in this material.

It is possible that the products described in this material may be combined with other products by the user for purposes determined solely by the user. No representations are intended or made as to the suitability of or engineering balance of or compliance with regulations or standard practice of any such combination of products or components the user may employ.

This equipment is only one component of a cabinet blasting operation. Other products, such as air compressors, air filters and receivers, abrasives, equipment for ventilating, dehumidifying, or other equipment, even if offered by Clemco, may have been manufactured or supplied by others. The information Clemco provides is intended to support the products Clemco manufactures. Users must contact each manufacturer and supplier of products used in the blast operation for warnings, information, training, and instruction relating to the proper and safe use of their equipment.

© 2017 CLEMCO INDUSTRIES CORP.
One Cable Car Dr.
Washington, MO 63090
Phone (636) 239-4300
Fax (800) 726-7559
Email: info@clemcoindustries.com
www.clemcoindustries.com



1.5.3 Each solenoid and diaphragm valve is opened in sequence until all cartridges have been cleaned once, and then the cycle is repeated. If the switch on the sequence panel is kept in the ON position, the sequence control panel energizes when the exhauster is turned ON, and stops when the exhauster is turned OFF.

1.5.4 The timers that control the ON and OFF time of the air pulse are located in the sequence control panel. The ON time should never be adjusted. The OFF time controls the length of time between each pulse. The shorter the OFF time, the more frequent the pulse cycles. Refer to Section 4.2.

1.5.5 The differential-pressure gauge shows the pressure difference between the dirty and clean side of the filters. The gauge helps determine the proper setting for the timer OFF time.

2.0 SET-UP and ASSEMBLY

2.1 General Assembly Notes

NOTICE

All seams assembled on the job site must be sealed to weather-tight condition. Use mastic tape and caulking on all seams as shown on the assembly drawings.

2.1.1 Review the assembly instructions and drawings before assembling and positioning the dust collectors.

2.1.2 Refer to the assembly drawing provided with the collector. Give special attention to the orientation of the inlet (flex hose connection), the direction in which the access cover swings up to open, and exhauster location. If the collector is part of a blast room or automated blast cabinet, use the general arrangement drawings for the placement of the components. Pay attention to the notes on the drawing, which assist in the assembly.

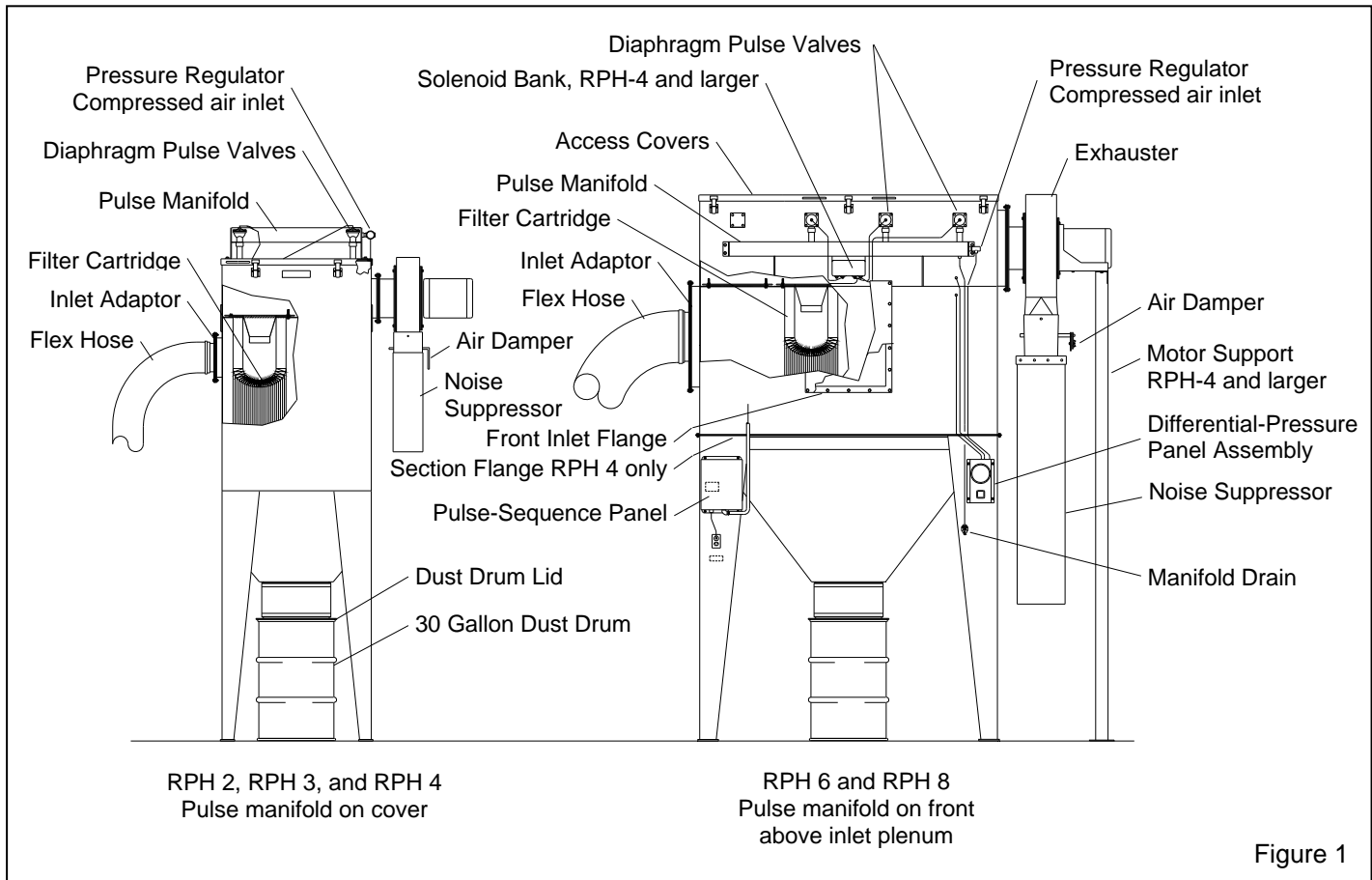

Figure 1

2.1.3 Erect the collector using the following instructions and the assembly drawing provided.

2.1.4 The dust collector must be installed on a sound foundation.

2.1.5 Select a location where compressed air and electrical service are available. The location must comply with OSHA and local safety codes. Space is required to access the dust drum and ample space is required above the collector to install and change filter cartridges. Refer to the table in Figure 2 for the approximate collector height (with silencer facing down) and the height required to change cartridges.

Model	Collector Height With Cover Open	Height Needed to Change Cartridge	Approx. Weight
RPH 2	143 inches	152 inches	1180 lbs.
RPH 3	143 inches	152 inches	1805 lbs.
RPH 4	144 inches	153 inches	1950 lbs.
RPH 6	171 inches	171 inches	2140 lbs.
RPH 8	171 inches	171 inches	2300 lbs.

Figure 2

NOTE: The height shown to change the cartridge is based on lifting the cartridge straight up and does not include space needed to position lift equipment that may be required to handle a heavily loaded cartridge.

2.1.6 Position the collector so the inlet flex hose has as few bends as possible. Determine the best location and position all units before making the final assembly.

2.2 Assembly

WARNING

Weight of an assembled dust collector varies among models; refer to the table in Figure 2 for approximate weights. Uprighting the collector, assembling sections, and moving it into position should be performed by experienced personnel who are familiar with safety hazards associated with handling steel material of this sort, using only approved tools and hoists that are required for safe erection of this product.

2.2.1 Place the skid(s) close to the collector's final position and remove all shipping restraints.

2.2.2 RPH dust collectors are shipped lying down on their side. Cartridges are not installed because of potential damage that can occur during shipping.

NOTE: RPH 4 dust collector is shipped upright in two sections (hopper/leg assembly, and body section). Because the body is shipped upright, cartridges are installed. The body and hopper/leg sections must be assembled. Refer to the assembly drawings paying particular attention to the notes, which include assembly instructions and sealing between the body and hopper flanges.

2.2.3 Fasten chains or slings through the lifting eyes; secure it to the lift equipment and lift the collector upright. Make sure the sling and lifting equipment are rated for the weight of the collector and that the operator is trained in handling the equipment. Refer to Paragraph 2.1.2 for approximate weights.

2.2.4 Position the collector in its projected final location that complies with OSHA and local safety codes. Provide ample space at the top to open the cover to access and replace the cartridges and at the front, ends, or back, to remove the dust container.

NOTE: RPH 6 and RPH 8 collectors have an optional front inlet-duct flange. Use the front inlet instead of the end inlet when space limitation or orientation make it favorable to do so. Refer to the assembly drawing provided. If the collector is part of an engineered product, use the general arrangement drawings provided with the project manual for the suggested orientation.

2.2.5 Exhauster Assembly

NOTE: For shipping purposes, exhausters are shipped loose and must be attached to the collector body.

NOTICE

RPH 4, RPH 6, and RPH 8 dust collectors are equipped with heavy exhausters that require additional motor supports. Do not remove exhauster's lifting rigging until the motor support are firmly attached. Failure to support the exhauster can cause damage to the exhauster or dust collector body.

2.2.5.1 Attach exhauster (and motor support when required) to the collector body.

2.2.5.2 Attach noise suppressor to the exhauster outlet. The suppressor can be facing up or down, but require rotating the exhauster housing.

2.3 Anchors

2.3.1 Recheck orientation of the dust collector, blast cabinet and reclaimer, or other equipment the collector is ventilating. When satisfied that all are correctly positioned, anchor modules to the floor with anchors specified by a qualified engineer. **NOTE: If there is any doubt about the final positioning of the dust collector, do not remove the lifting equipment until the collector is fully assembled, connected to the mating equipment, and ready to be anchored.**

2.3.2 After the collector is firmly anchored, remove the lifting rigging.

2.4 Flex Inlet Ducting

2.4.1 Cut the hose to length to provide a connection loose enough to avoid stretching the hose, but taught enough to prevent excessive sagging. Support the hose if needed.

2.4.2 Attach the flex hose between the dust collector inlet and equipment the dust collector is ventilating. Secure with clamps provided.

2.5 External Grounding

2.5.1 To dissipate static electricity, attach an external grounding wire from an earth ground to the grounding lug located next to the pulse-sequence panel.

2.6 Electrical Service

2.6.1 Electrical Installation Notes

WARNING

Shorting electrical components can result in serious electrical shocks, or equipment damage. Electrical power must be locked out and tagged out before performing any electrical work. All electrical work or any work done inside a control panel or junction box must be performed by a qualified electrician, and comply with applicable codes.

NOTE: A wiring schematic for the pulse-sequence control panel is stowed inside the panel. Refer to the schematic to wire the pulse-sequence circuit board.

All wiring is to be provided by the user and it is to comply with applicable electrical codes.

Electrical requirements depend on the size and phase of the motor. Standard dust collectors are supplied as follows:

- 600 cfm, 1 HP, 115/208-230 V, 1 PH, 60 HZ
FLA 115/12, 208/6.6, 230/6.2.
- 600 cfm, 1 HP, 208-230/460 V, 3 PH, 60 HZ
FLA 208/3.4, 230/3.2, 460/1.3
- 900 cfm, 2 HP, 208-230/460 V, 3 PH, 60 HZ
FLA 208/5.2, 230/4.8, 460/2.4.
- 1200 cfm, 5 HP, 208-230/460 V, 3 PH, 60 HZ
FLA 208/12 to13, 230/12 to 13, 460/6
- 1800 cfm, 7.5 HP, 208-230/460 V, 3 PH, 60 HZ
FLA 208/19.6 to 17.8, 230/19.6 to 17.8, 460/8.9
- 2500 cfm, 10 HP, 230/460 V, 3 PH, 60 HZ
FLA 230/24.7 to 22.8, 460/11.4
- 3600 cfm, 15 HP, 230/460 V, 3 PH, 60 HZ
FLA 230/42, 460/21

Full load amps are approximate and may vary slightly. Refer to the motor plate for actual FLA.

2.6.2 Single-Phase Wiring for Blast Cabinets

2.6.2.1 Refer to the wiring schematic in Figure 3. Wire the dust collector motor per instructions on the motor data plate to the junction box mounted on the cabinet. When wired as noted in Figure 3, the exhauster motor will start when the cabinet light switch is turned ON, and stop when the switch is turned OFF.

2.6.3 Three-Phase Wiring for Blast Cabinet

2.6.3.1 Refer to the wiring schematic stowed inside the control panel mounted on the cabinet. Wire from the users disconnect to the panel and from the panel to the dust collector motor, per instruction on the motor data plate.

2.6.3.2 Check the amperage on initial start up; if the motor draws excessive amperage, gradually close the dust collector damper, located on the exhauster outlet, until the amperage is within the specifications shown on the motor plate.

2.6.4 Three-Phase Wiring for Recovery System

2.6.4.1 When the dust collector comes with a recovery system that includes a control panel (panels are generally not included unless ordered as a separate item), a wiring schematic is stowed inside the panel. Wire from the user's disconnect to the panel and from the panel to the dust collector motor per instruction on the motor data plate.

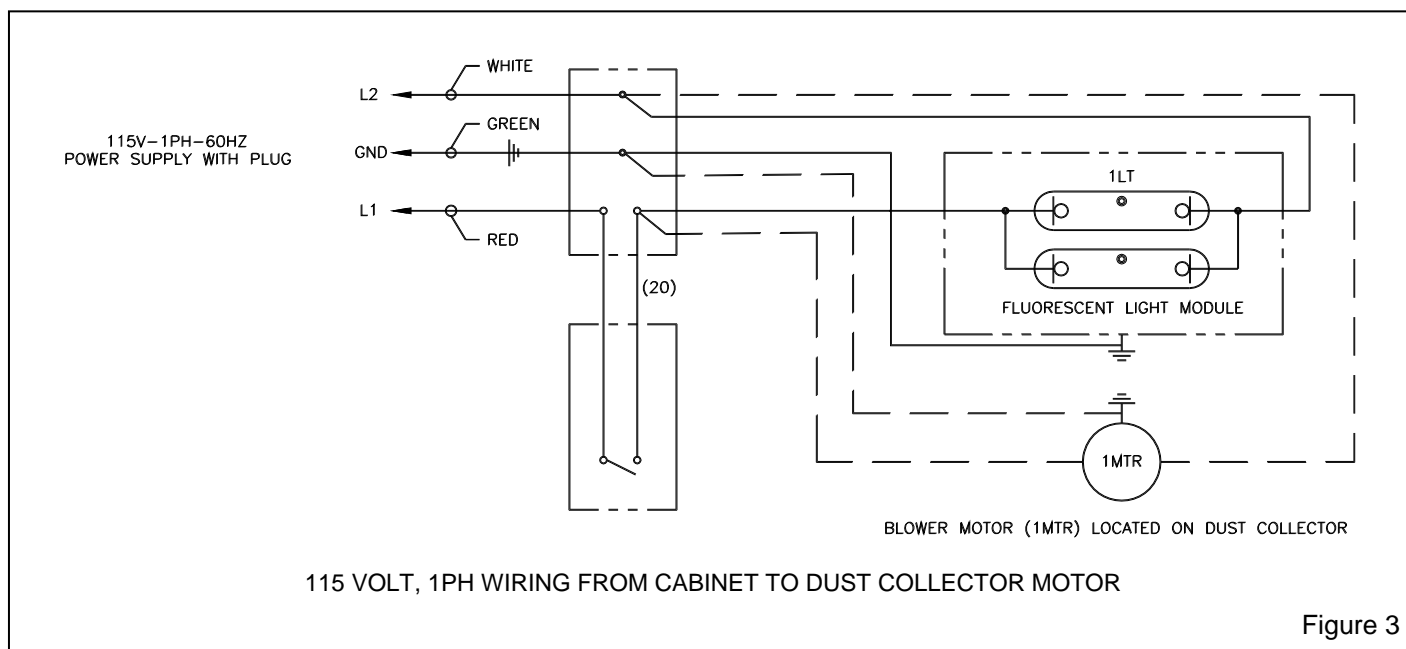

2.6.4.2 If a panel is not included, wire the motor, as noted on the motor data plate to a user-supplied control panel. The collector motor should be wired in series with other system motors. Generally, the dust collector should start before other system components.

2.6.4.3 Check the amperage on initial start up; if the motor draws excessive amperage, gradually close the dust collector damper, located on the exhaust outlet, until the amperage is within the specifications shown on the motor plate.

2.6.5 Check Motor Rotation

2.6.5.1 After wiring is completed, observe the following warning, and check the motor rotation. To check rotation, jog the starter (momentarily turn switch ON and OFF). This causes the motor to rotate slowly. Look through the slots in the motor fan-housing, where rotation of the fan can easily be observed. Proper rotation is indicated by the arrow on the exhaust housing; the fan should rotate toward the exhaust outlet.

⚠ WARNING

Do not look into the exhaust outlet while the paddle wheel is turning. Injury to the eye or face can occur from objects being ejected from the exhauster.

2.7 Compressed Air Connections

NOTICE

The air source for the filter pulse must be 35 to 50 degrees Fahrenheit dew point and be free of any oil contaminants. If line air does not meet this requirement, an optional air dryer is recommended. Moisture or oil contaminants in the pulse system will decrease cartridge life and filtering efficiency.

⚠ WARNING

Failure to observe the following before connecting the equipment to the compressed air source can cause serious injury or death from the sudden release of compressed air.

- **Lockout and tagout the compressed air supply.**
- **Bleed the compressed air supply line.**

2.7.1 Connect an air fitting that is compatible with the air supply hose (refer to Paragraph 2.8.2), to the pulse-pressure regulator located on the inlet of the pulse manifold. Note that the style of connections shown in Figure 4 is for reference only. If the application is suitable for hard-pipe, pipe may be used.

2.7.2 To enable depressurization for service, install an isolation valve where the air line is connected to the compressed-air source. The size of the line depends on the size of the collector. The compressor and air line must be large enough to provide at least 3 cfm per

cartridge. The air line should not be smaller in diameter than the manifold inlet at the regulator.

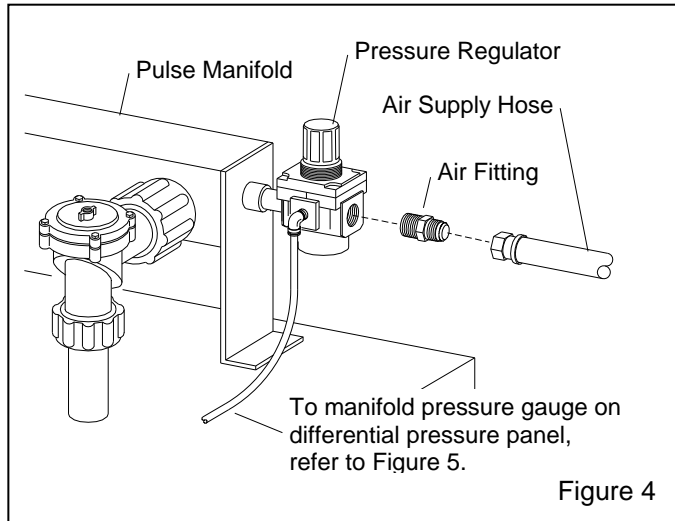

2.7.3 Purge the air supply line to remove moisture or other foreign material before connecting it to the pulse manifold.

2.7.4 Some tubing may be disconnected for shipping purposes. Refer to the general arrangement in Figure 1 and the illustration of the differential-pressure indication panel in Figure 5 to confirm that all connections are made.

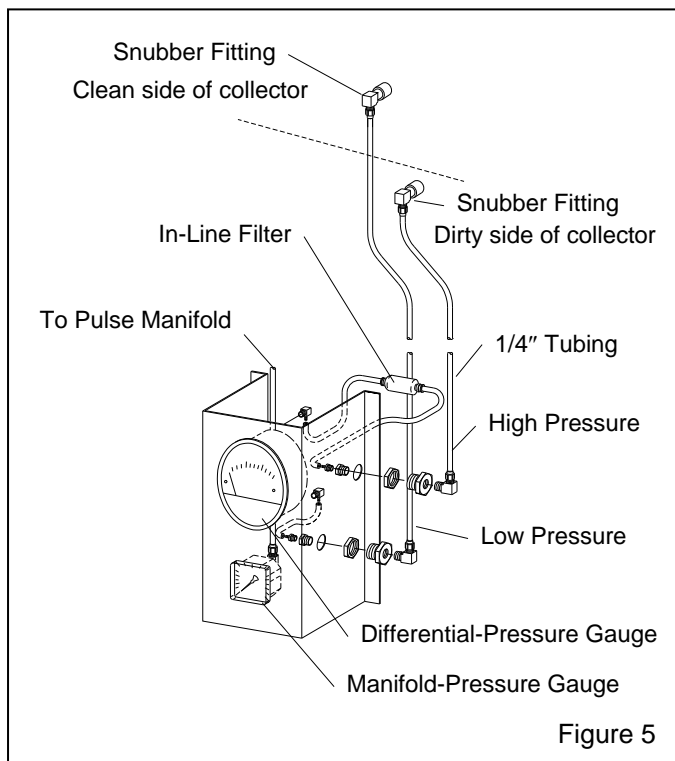

2.8 Install Filter Cartridges, Figure 6

NOTE: Filter cartridges are shipped loose to avoid damage during transportation.

WARNING

Fall Hazard: Follow OSHA Regulations in 29CFR1910 Subpart D and F, for fall protection when working above 4 feet.

2.8.1 Unlatch the access cover and swing the cover up to open.

2.8.2 Unclip the safety bar from the underside of the access cover and place the end into the hole on the top flange.

2.8.3 Remove the hold-down plates from each cartridge opening.

2.8.4 Remove the venturi tube and filter cartridge from the shipping carton.

2.8.5 Make sure the top of the cartridge plate is clean, then lower the cartridge into the opening as shown in Figure 6 until the cartridge flange rests on the cartridge plate.

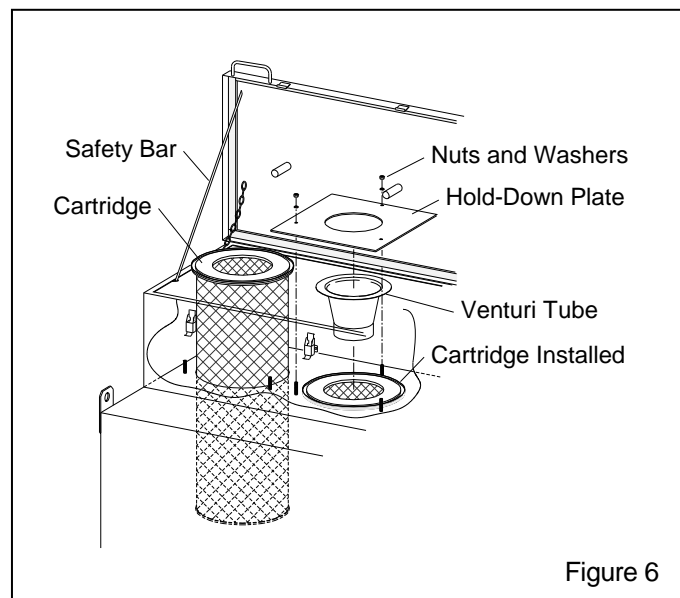

2.8.6 Install venturi tube, and secure with hold-down plate as each cartridge is installed.

2.8.7 Undo the safety bar, clip it to the underside of the access cover, and close and latch the cover.

2.9 Dust Containers

- 2.9.1 Place dust drum(s) under the hopper(s).
- 2.9.2 Place a lid onto each drum.
- 2.9.3 Place the clamp ring around the lids and tighten the clamp bolt to secure.
- 2.9.4 Attach a flex hose between hoppers and dust drum lids. Secure both ends of the flex hose with clamps provided.

NOTICE

All flex hose connections made at the bottom of the hopper and the lid must be airtight.

3.0 OPERATION

⚠ WARNING

Everyone operating and servicing this equipment must be made aware of the hazards associated with abrasive blasting, and handling toxic materials, including lead dust. Toxicity and health risks vary with the type of media used and dust generated by blasting. Identify all material being removed by blasting, and obtain a Safety Data Sheet (SDS) for the blast media.

NOTICE

The dust collector access-cover must be secured, and the dust container, cover, and flex hose must be secure when the dust collector is in operation.

3.1 Initial Start-up

NOTICE

Do not pulse new dust collectors or replacement cartridges until cartridges are properly seasoned per Section 6.2. Pulsing unseasoned cartridges can cause premature cartridge failure and decrease the efficiency of dust collector.

3.1.1 Turn OFF the sequence switch and pressurize the air supply line to the pulse regulator.

3.1.2 Refer to Section 4.1 and adjust pulse pressure to 100 psi, and check all pneumatic connections for leaks.

3.1.3 Turn pulse pressure to 20 psi and switch the pulse sequence ON. Check the air pulse and sequence of the diaphragm pulse valves, solenoids, and panel timer. After all items are checked, adjust the pulse pressure to 70 psi, and turn the sequence switch OFF.

NOTICE

Do not turn the sequence switch on until the cartridges are seasoned. Refer to Section 6.2.

3.2 Operational Start-Up

3.2.1 Make sure access covers are closed, and dust drums are secure.

3.2.2 Check to make sure the sequence switch is ON. **Do not switch the sequence panel on until the cartridges are seasoned per Section 6.2.**

3.2.3 Pressurize the pulse manifold and check the manifold pressure.

3.2.4 Start the exhauster at the control panel.

3.3 Shutdown

3.3.1 Allow the system to run until all system components are empty (refer to accessory components operation manuals) and all areas ventilated are free of airborne dust.

3.3.2 Turn off the exhauster.

3.3.3 Shut off the air supply to the pulse manifold.

3.3.4 Drain the pulse manifolds. The drain cock is located below the differential-pressure panel; refer to Figure 1. Drain whenever the air supply is turned OFF.

3.3.5 Check dust receptacles and empty when needed.

4.0 ADJUSTMENTS

4.1 Pulse-Manifold Pressure

NOTICE

Do not pulse new dust collector or replacement cartridges until cartridge are properly seasoned per Section 6.2. Pulsing unseasoned cartridges can cause premature cartridge failure and decrease the efficiency of dust collector.

4.1.1 The pulse-pressure regulator is located on the pulse reservoir inlet, as shown in Figure 4; the pressure gauge is mounted below the differential-pressure panel for convenient monitoring. After the cartridge is seasoned per Section 6.2, adjust pressure to 70 psi.

4.1.2 To adjust pressure, pull the regulator knob out to unlock as shown in Figure 7. Turn it clockwise to increase pressure or counterclockwise to decrease pressure. Once pressure is set, push the knob in to lock it and maintain the setting.

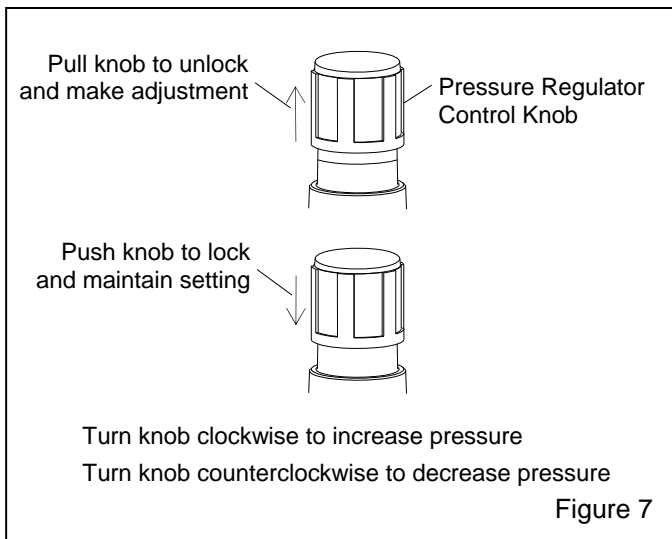

4.1.3 When the frequency of the pulse cycles as noted in Section 4.2 will not lower the differential pressure to less than 4" water column (W.C.), increase pulse pressure in increments of 10 psi until the maximum of 100 psi is reached.

4.1.4 When the maximum pulse pressure of 100 psi is attained and the minimum pulse OFF time of 20 seconds does not lower differential pressure below 4" W.C., replace the cartridge per Section 6.1.

4.2 Pulse-Sequence Control Panel and Timer

4.2.1 A toggle switch mounted on the sequence control panel cover (located on the dust collector stand) enables or disables the sequencer. If the switch is ON, the pulse sequence will automatically start whenever the dust collector exhauster is started. If the switch is OFF, the pulse sequence will not occur. The switch should be left OFF (no pulse) until the cartridges are seasoned per Section 6.2.

4.2.2 The timer (located in the sequence panel, on the upper left corner of the circuit board) is factory set at 40 seconds OFF and 15/100 of a second ON. Every 40 seconds, one filter bank is pulsed in sequence until all filters have gone through a cycle.

4.2.3 As the filters cake with dust, the pulse may not clean them well enough to bring the differential pressure below the recommended changeover pressure of 4" W.C.. A constant reading higher than 4" is an indication that more frequent pulse cycles or higher pressure are needed. When the differential-pressure gauge shows a constant pressure difference greater than 4", adjust the OFF time setting by half, per circuit board instruction stowed inside the panel. **DO NOT ADJUST ON TIME.** Increasing ON time will consume more air, but will NOT increase cleaning efficiency.

4.2.4 When the frequency of the pulse cycles and higher pulse pressure will not lower the differential pressure below the changeover pressure of 4" W. C., the filter cartridges should be replaced per Section 6.1, the timer OFF time should be reset to 40 seconds, and pressure set to 70 psi.

4.3 Outlet Damper

4.3.1 Refer to Figure 8 and adjust the damper by rotating the handle. The damper plate lines up with the handle; when the handle is horizontal the damper is fully closed, when the handle is vertical, the damper is fully open.

4.3.2 Cabinet and Reclaimer: Adjust damper to attain static pressure as noted in the cabinet or reclaimer manual.

4.3.3 AWAC Abrasive Cleaner: Set the damper to fully open and use the AWAC damper to make adjustments as noted in the AWAC Abrasive Cleaner manual.

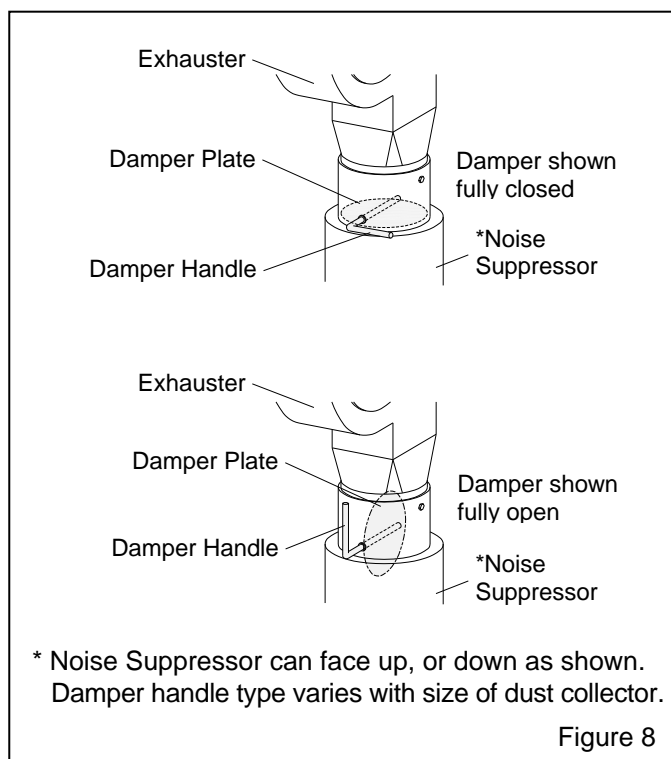

5.0 PREVENTIVE MAINTENANCE

⚠ WARNING

Prior to doing any maintenance or opening the dust collector, the employer must meet OSHA standards required but not limited to 29CFR 1910 for

- **Appropriate Respirator**
- **Protective Clothing**
- **Toxic and Hazardous Substances**
- **Fall Protection**

Toxicity and health risk vary with type of dust generated by blasting. Identify all material that is being removed by blasting, and obtain a Safety Data Sheet (SDS) for the blast media. Waste dust in the collector can cause serious injury or death through inhalation, absorption, or consumption. The employer shall meet all OSHA requirements including those for: confined space, combustible dust, fall protection, and hazard communication.

⚠ WARNING

Make sure the following conditions are met before performing any maintenance on the collector.

- **Turn off compressed air supply and drain air from pulse manifolds.**
 - **Lockout and tagout electrical power.**
- Failure to observe the above warnings can result in serious injury from the sudden release of trapped compressed air.**

5.1 Daily

5.1.1 Empty dust drums.

NOTE: Check dust drums daily until the dust collection rate is determined. Setup a program to empty the drums before they are 2/3 full. Dust should never accumulate in the hoppers.

5.1.1.1 Empty and/or replace the drums; when reattaching lids make sure they are secured to the drums.

5.1.2 Check exhaust air for dust during pulse; dust is an indication of a loose or damaged filter cartridge.

5.1.2.1 If dust is seen coming out the exhauster, filters are leaking or damaged. Check immediately. To determine which cartridge is leaking, turn the sequence switch off, open the top access cover and check the inside of the collector for dust trails. NOTE: A small amount of dust egress is normal for a short time when cartridges are new.

5.1.3 Check the differential-pressure gauge at least once daily. If the reading is continually high (greater than 4" W.C.), adjust pressure and/or sequence timing per Sections 4.1 and 4.2.

5.2 Weekly

5.2.1 Check the inside of the collector for moisture. If moisture is caused by leaks, repair immediately.

5.2.2 Clean the differential-pressure gauge in-line dust-filter located behind the gauge panel. Refer to Figure 5.

6.0 SERVICE MAINTENANCE

⚠ WARNING

Prior to doing any maintenance or opening the dust collector, the employer must meet OSHA standards required but not limited to 29CFR 1910 for

- Appropriate Respirator
- Protective Clothing
- Toxic and Hazardous Substances
- Fall Protection

Toxicity and health risk vary with type of dust generated by blasting. Identify all material that is being removed by blasting, and obtain a Safety Data Sheet (SDS) for the blast media. Waste dust in the collector can cause serious injury or death through inhalation, absorption, or consumption. The employer shall meet all OSHA requirements including those for: confined space, combustible dust, fall protection, and hazard communication.

⚠ WARNING

Make sure the following conditions are met before performing any maintenance on the collector.

- Turn off compressed air supply and drain air from pulse manifolds.
 - Lockout and tagout electrical power.
- Failure to observe the above warnings can result in serious injury from the sudden release of trapped compressed air.

6.1 Replacing Filter Cartridge

6.1.1 Lockout and tagout the compressed air supply and electrical power.

6.1.2 Empty the dust receptacles.

6.1.3 Unlatch the access cover and swing the cover up to open.

6.1.4 Unclip the safety bar from the underside of the access cover and place the end into the hole on the top flange.

6.1.5 Remove the nuts and washers (three per plate) securing the filter hold-down plate.

6.1.6 Remove the hold-down plates and venturi tubes.

6.1.7 Remove all filter cartridges. A small amount of force may be necessary to loosen the seal of the filter gasket.

6.1.8 When all filters are removed, clean the inside of the collector to remove loose dust or hardened dust clods, particularly from the cartridge-sealing surface, and the clean-air side (top side) of the cartridge sheet.

6.1.9 Lower the new cartridge into the opening as shown in Figure 9 until the cartridge flange rests on the cartridge plate.

6.1.10 Install venturi tube, and secure with hold-down plate as each cartridge is installed.

6.1.11 Inspect the gasket on the access cover. Replace the gasket if it is worn or damaged.

6.1.12 Undo the safety bar, clip it to the underside of the access cover, and close and latch the cover.

6.1.13 Reset timer OFF time to 40 seconds, and set pulse pressure to 70 psi.

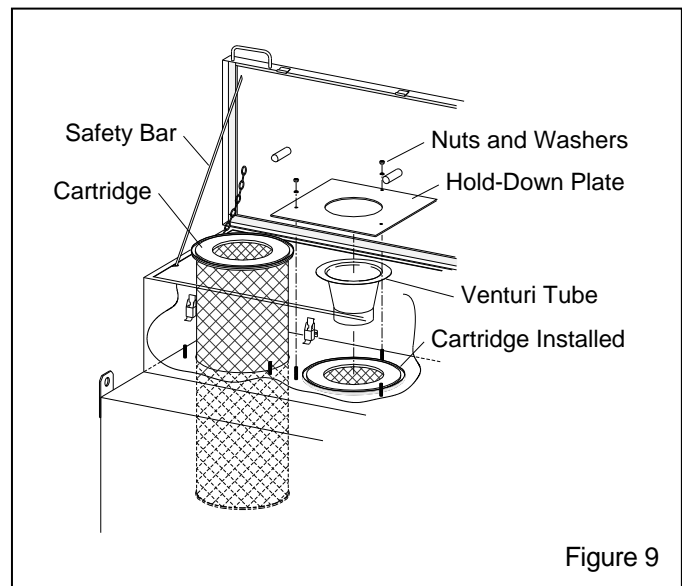

Figure 9

6.1.14 Turn the sequence panel OFF and season cartridges per Section 6.2.

6.2 Seasoning New Cartridges

NOTE: Filter cartridges must be seasoned before the initial start-up and each time the cartridges are replaced.

6.2.1 New cartridges must be seasoned before starting the pulse cycle. Cartridges are seasoned by letting a layer of dust (dust cake) develop on the outer surface of the filter media. The dust cake protects the filter cartridge, and enhances the filtering efficiency; it is the dust cake that actually does the filtering.

6.2.2 Operate the dust collector without pulsing (sequence switch turned OFF) until the differential-pressure gauge reads the recommended changeover pressure of 4" W.C.. Then set the pulse cycle sequence to factory settings per Section 4.2.2 and turn ON the sequence switch to start the pulsing cycle.

6.3 Tube fittings

6.3.1 If it becomes necessary to remove or replace the tubing between quick-release valves and panel, be sure the tubing does not bottom out in the fitting. If the tubing is inserted too far into the fitting, it will block the air passage, and cause the pulse to malfunction.

7.0 TROUBLESHOOTING

WARNING

Shut down the collector immediately if dust discharges from the exhaustor. Check the cartridge to make sure it is seated and not worn or damaged. Prolonged breathing of abrasive dust and blasting by-product dust can result in serious lung disease or death. Short term ingestion of toxic dust such as lead, poses an immediate danger to health. Identify all materials to be removed by blasting, and obtain a safety data sheet (SDS) for the blast media.

7.1 Collector not pulsing

7.1.1 Check the manifold pressure gauge. If pressure is low, check the compressed air supply; look for a leak or closed supply valve.

7.1.2 Check function of the pressure regulator located on the pulse manifold inlet, make sure it has not been turned down or turned off.

7.1.3 Make sure the sequence switch located on the panel cover is ON.

7.1.4 Check the fuse in the sequence control panel. Replace as necessary.

7.1.5 Have a qualified electrician check for electrical malfunction; check the supply voltage to the pulse-sequence board. Check outlet voltage to solenoids.

7.2 Some cartridges not pulsing

7.2.1 Solenoid defective. Have a qualified electrician check for electrical malfunction.

7.2.2 Check the diaphragm in pulse valves.

7.2.3 Check for blockage in the tubing between the diaphragm pulse valve and solenoid assembly.

7.3 Pulse is steady stream of air instead of a quick pulse.

7.3.1 Check for a leak or split in the tubing between the diaphragm pulse valve and solenoid assembly.

7.3.2 Solenoid remaining in open position. Have a qualified electrician check for electrical malfunction, clean, or replace.

7.4 Exhauster not running

7.4.1 Exhauster overload could be tripped. Have a qualified electrician reset and check for overload.

7.4.2 Make sure that the main disconnect is in the ON position.

7.4.3 Motor faulty. Have a qualified electrician check for electrical malfunction.

7.5 Excessive differential pressure

7.5.1 Valves may not be pulsing properly. Refer to Section 7.1.

7.5.2 The differential-pressure gauge lines may be plugged with dust. Check and clean.

7.5.3 Make sure the tubing has not been inserted so far into the tube connection elbows that the tube ends are blocked.

7.5.4 The in-line dust filter may be blocked. Check and replace.

7.5.5 Snubber fitting blocked with dust. Clean or replace. Refer to Figure 5.

7.5.6 The sequence OFF time may need adjusting. Refer to Section 4.2.

7.5.7 The filter cartridges may need to be replaced. Refer to Sections 4.2. and 6.1.

7.6 No reading on differential-pressure gauge.

7.6.1 Check to make sure the low and high pressure lines have not been reversed. Refer to Figure 5.

7.7 Dust discharging from exhauster.

7.7.1 Check for loose or damaged filter cartridge.

7.7.2 Cartridges not seasoned. Refer to Section 6.2.

8.0 REPLACEMENT PARTS

**8.1 Differential-Pressure Indication Panel
Figure 10**

Item	Description	Stock No.
(-)	Indication Panel Assembly, includes the mount and items with an asterisk (*)	15663
1.*	Gauge, pressure	19150
2.*	Gauge, differential-pressure	10188
3.	Snubber fitting	15786
4.*	Filter, in-line dust	23415
5.*	Fitting, 1/8" NPT straight x 1/8" barb	11732
6.*	Fitting, 1/8" NPT-F x 1/4" tubing	15703
7.*	Elbow, 1/8" x 90° brass st.	03993
8.*	Fitting, 1/8" NPT elbow x 1/8" barb	11733
9.*	Fitting, 1/4" NPT elbow x 1/4" tubing	03428
10.*	Tubing, 1/8" urethane, Specify ft. req.	12475
11.*	Fitting, 1/4" NPT female bulkhead	05605
12.*	Bushing, 1/4" NPT x 1/8" NPT brass	02010
13.	Tubing, 1/4" OD, specify feet required	15892

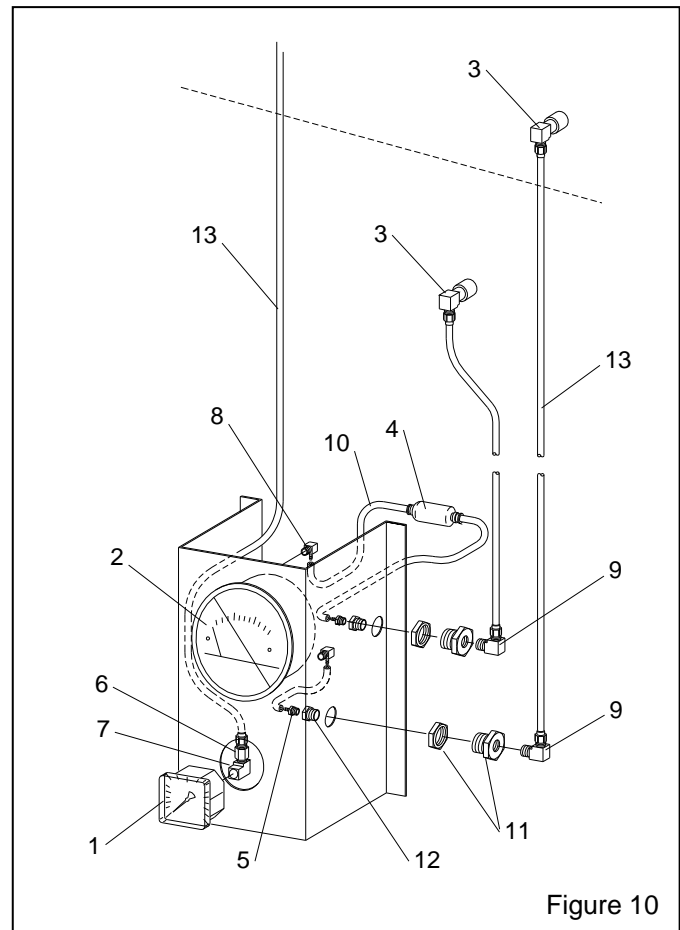

Figure 10

8.2 Common Replacement Parts, Figure 11

Refer to the assembly drawings provided with the dust collector for replacement parts specific to the dust collector supplied. Any parts for a dust collector furnished on a project that do not have a stock number, should be ordered by referencing the project number, drawing number, drawing item number, part description, location, and quantity

Item	Description	Stock No.
(-)	Service kit for 1-1/2" pulse valve (Item 1) ...	21601
1.	Valve, 1-1/2" diaphragm pulse	15818
2.	Cartridge, filter, 13" x 36"	15781
3.	Solenoid, not shown for RPH-2 & RPH-3 only	23869
4.	Solenoid bank assembly, 5 valve bank for RPH-4, 6, 8, 20 & larger.	15743
	6 valve bank for RPH-10 & 12.....	15742
	8 valve bank, for RPH-16	15744
5.	Solenoid, individual replacement for 5 & 8-solenoid bank	24198
	for 6-solenoid bank	27044

6.	Petcock, 1/4" drain	01993
7.	Circuit board, pulse-sequence (not shown) for RPH-2 & RPH-3 only	10261
	Dwyer board for earlier collectors RPH-4 and larger except RPH-16.....	23871
	Ametek NCC board for current collectors RPH-4 and larger except RPH-16	15745
	for RPH-16	15746
8.	Flex hose, one foot required 16" dia., RPH-2 thru RPH-16	15667
9.	Latch	10290
10.	Dust drum, 30-Gallon for RPH-2 thru RPH-16	15668
11.	Lid/hose adaptor, dust drum 30-Gallon, w/16" dia. hose inlet	15670
12.	Tubing, 1/4" OD, specify feet required	15892
13.	Gasket, 1" x 5/16", six feet required.....	00187
14.	Clamp, flex hose 8.5", for 16" hose (use 2 on each end) .	11576
15.	Regulator, pressure, with gauge 1/2" for RPH-2 thru RPH-4	01902
	1" for RPH-6 thru RPH-16	01904

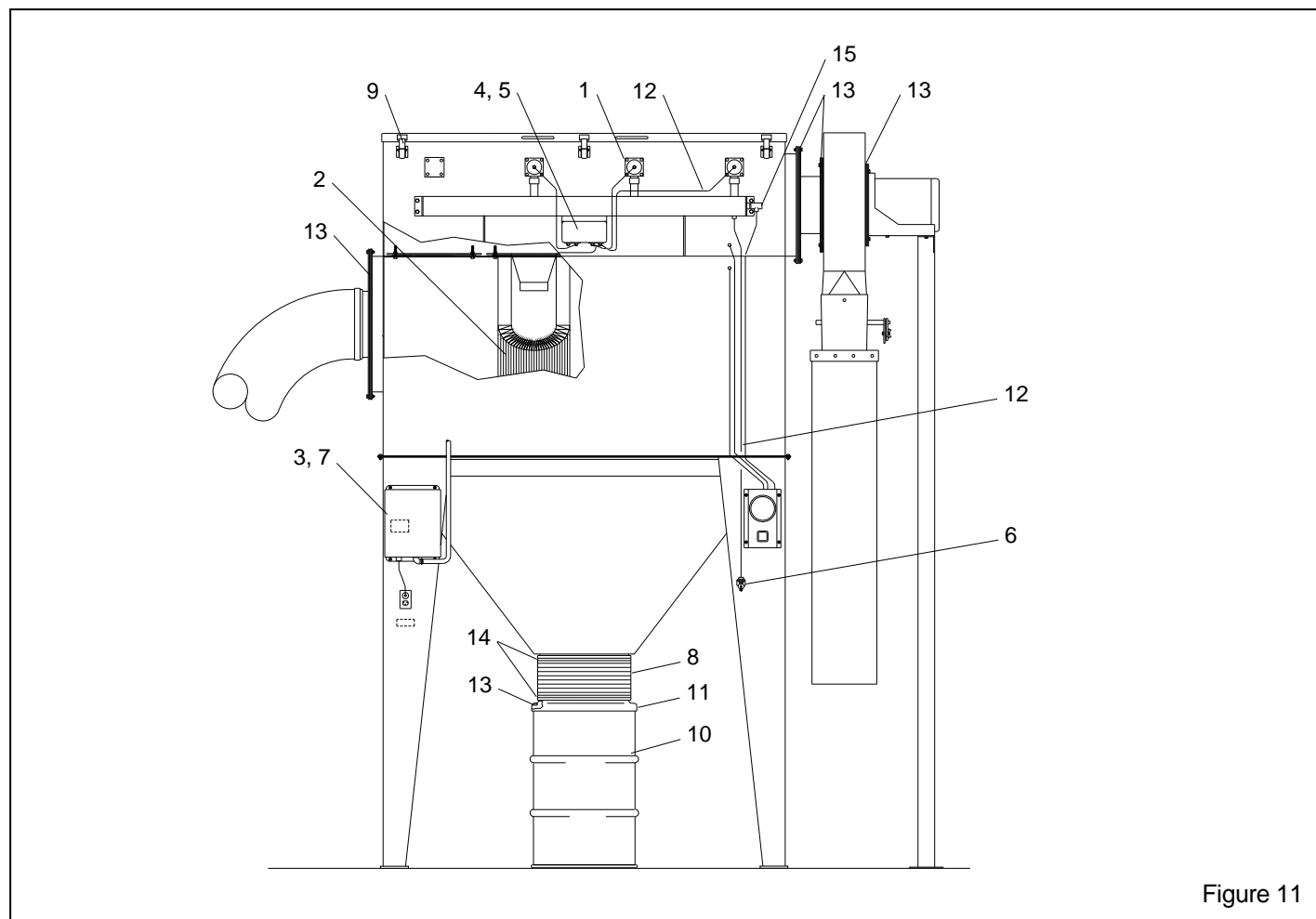

Figure 11