



★★★★
MADE IN THE
USA

4-GALLON TUMBLE-BASKET BLAST CABINET

COMPLETE, HIGH-PRODUCTION CABINET SYSTEM WITH A COMPACT FOOTPRINT

IMPORTANT: For safe and efficient blasting, read and follow the operations manual and seek training for everyone who will use this equipment.



Automatically blast batches of parts with a cabinet that provides consistent parts coverage, is far more efficient than manual blasting, and has a compact footprint.

OVERVIEW

Tumble-basket system that automatically blasts batches of parts while recovering media. Its small footprint accommodates cell-manufacturing floorplans and other space restrictions. Batch processing achieves consistent parts coverage over intricate and less-complex part designs; almost impossible with manual blasting. By reducing operator handling and increasing production capacity, batch processing blasts more parts far more quickly than manual blasting. The cabinet requires less downtime and maintenance than similar competitor models, and is easier to operate.

TUMBLE BASKET

Four-gallon capacity holds batches up

to 35 lbs. The variable-speed barrel can operate from 1 to 15 rpm. Features a 0-60 minute, manually set, blast-cycle timer.

Removable-Barrel Specifications

- 16" diameter x 13" deep
- 10ga x 1/8" perforated steel body
- 3/8" steel-barrel end plate

Barrel-Drive Specifications

- 1/4 HP
- 115V, 1 PH, 60 Hz
- DC motor and 100:1 gear reducer coupled to a 1" diameter drive shaft

BLAST CABINET ENCLOSURE

Constructed with 14ga steel. Features a safety door interlock and a quick-change, tilt-out view window. The enclosure door swings open to allow unobstructed loading and unloading of parts, as well as simplified barrel removal.

• Blast Cabinet Footprint (with plumbing and closed door)

28" W x 41" D x 73" H

• Blast Cabinet Footprint (with plumbing and open door)

28" W x 68" D x 73" H

• Tilt-Out View Window

19.5" W x 12.5" H

PULSAR III, 300 CFM SUCTION POWER MODULE

• Dust Collector

300 cfm, reverse-pulse cartridge with a 1/2-HP exhaustor, a dust drum, and auto-pulse cartridge cleaning, which extends the service life of the cartridge.

Stock No. 29138

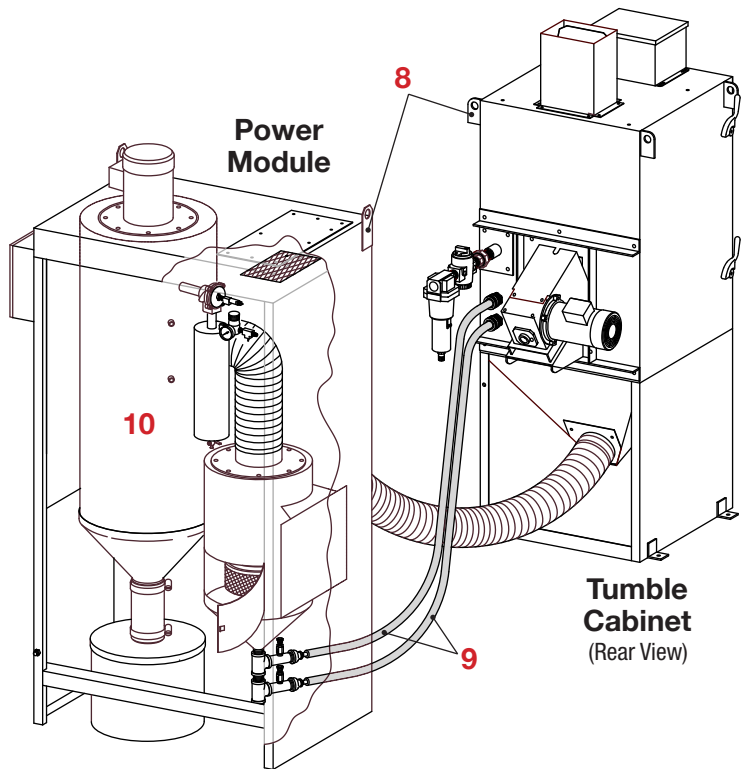
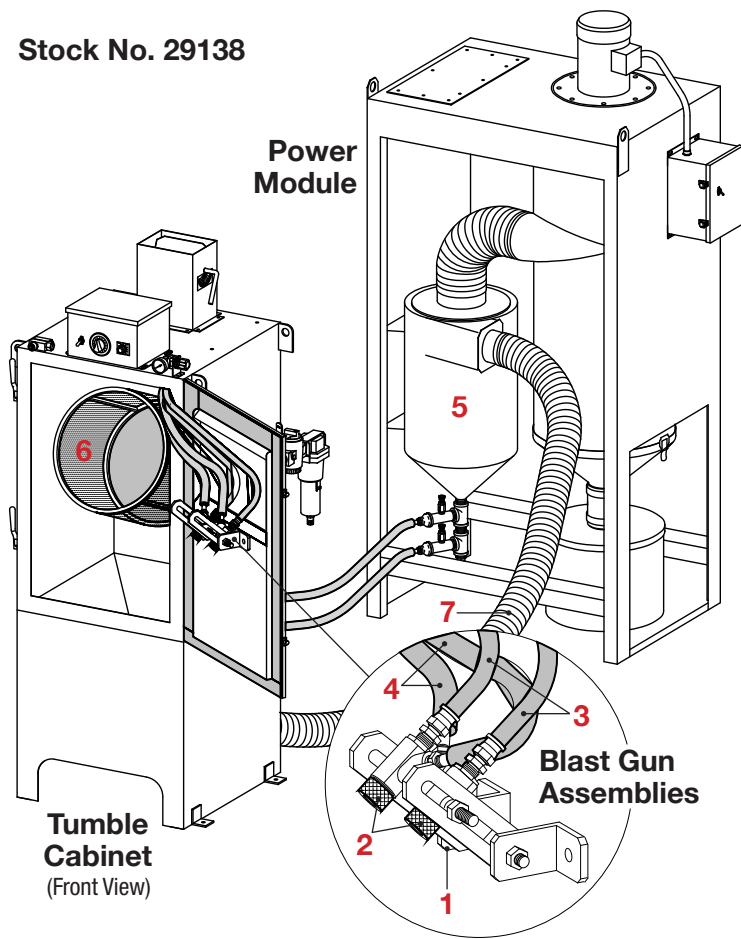

- **Media Recovery System**
300 cfm, pull-thru reclaimer with light-lined conveying hose, quick-removal debris screen, and rubber-lined wear plates.

- **Power Module Footprint**
43" W x 25.75" D x 82" H

SUCTION BLAST GUN SYSTEM

Two cast-steel gun bodies are stud-mounted onto the door. Door mounting eases blast-gun maintenance, unlike similar competitor models that attach guns to the interior cabinet roof. Each gun is equipped with a No. 5 (5/16") tungsten nozzle and has a BNP cast-aluminum, adjustable metering valve.

Specifications

- 5/32" adjustable air jets
- Requires 64 cfm at 80 psi

COMMON APPLICATIONS

Process sturdy or delicate parts up to 4" long for numerous industries, including:

- **Firearms**
Slides, springs, and mechanism hardware
- **General Industry**
Hardware and fasteners
- **Medical**
Screws and small medical tools

Diagram Key

1. Adjustable, Slotted Gun Bar
2. Blast Guns
3. Air Hoses (green)
4. Media Hoses (black)
5. Reclaimer
6. Tumble Basket
7. Flex Hose
(between the cabinet hopper reclaim inlet)
8. Lifting Eyes
9. Media Hoses
(between reclaimer hopper blast guns)
10. Dust Collector