

## MediPulse 2342se



MediPulse suction blast cabinet

*The ZERO MediPulse is a high-production, ergonomic suction blast cabinet designed specifically to enhance productivity and efficiency by offering a safe and comfortable work station for blast operators. Repetitive work is made easier by allowing workers to concentrate on achieving the desired surface treatment, working from a seated position at their option. Cabinet design minimizes floor space requirements.*

### MediPulse Suction Cabinet Features:

#### **Safety**

- ✓ Full-length, neoprene-on-fabric gloves resist wear and protect operator.
- ✓ Ceiling-mounted, two-tube fluorescent light fixture with abrasive-resistant Lexan® cover for extraordinary visibility.
- ✓ Safety interlocks interrupt blasting if either door is opened.
- ✓ Adjustable, heavy-duty chromed latches seal doors tight.

#### **Productivity**

- ✓ Unique air logic system to maximize air flow to the blast gun.
- ✓ Double-wall, sound-insulated doors, with industrial-quality lift-off hinges.
- ✓ 14-gauge steel all-welded construction, with precisely formed bends, creates a rigid, long-lasting cabinet enclosure.

#### **Convenience**

- ✓ Tilt-out window, for tool-free glass changes in minutes.
- ✓ Pressure regulator, gauge, and electric switch mounted within easy reach.
- ✓ Built-in blow-off gun removes residual media from parts and cabinet interior.

#### **Common Applications**

- ✓ Cleaning parts
- ✓ Deburring machined parts
- ✓ Improving surface finish
- ✓ Removing heat scale

**Clean  
Peen  
Deburr  
Finish**

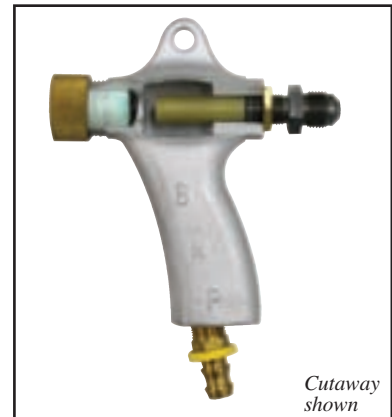

### BNP Blast Gun

The ZERO BNP blast gun sets the industry standard for performance, versatility, and durability. The ergonomic grip reduces operator fatigue and increases productivity. The standard ceramic nozzle is ideal for bead blasting, while the optional tungsten or boron carbide nozzles stand up to hundreds of hours of blasting with today's aggressive media.

### Popular Accessories/Options

- Adjustable Gun Mount
- Alox Kit
- Curtains (black or high-visibility white)
- HEPA filter
- Manometer Kit
- 20" Dia. Turntable
- Two Gallon Tumble Basket
- Timed Door Release
- Magnetic screen
- Rubber work grate mat
- Pressure blast system
- Media catch trays on doors
- Automatic pulse kit
- Table/work tray with internal track
- Bolt-on arm rest
- Stainless steel construction
- Noise reduction package
- Other options per customer specifications

# S P E C I F I C A T I O N S

## COMPLETE SYSTEM

Actual space requirements depend on desired work flow. Allow additional work space for operator and maintenance.

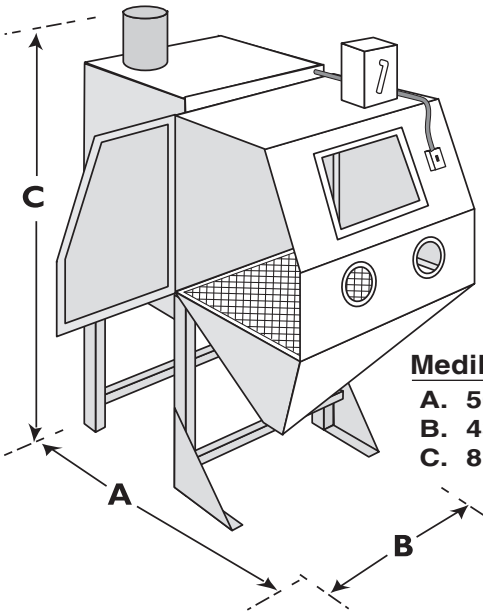

**MediPulse 2342se**  
**A. 50" (1270 mm)**  
**B. 43" (1092 mm)**  
**C. 81" (2057 mm)**

## CABINET

### Working Chamber Size

- A. 42" wide (1067 mm)
- B. 23" deep (584 mm)
- C. 30" high (762 mm)

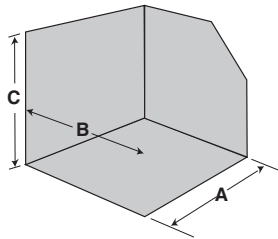

### Door Opening

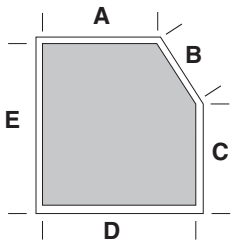

- A. 11.5" (292 mm)
- B. 18" (457 mm)
- C. 11" (279 mm)
- D. 21" (533 mm)
- E. 26.5" (673 mm)

### Electrical

1/2HP, 115V, 1PH, 60HZ  
 Some installations may require electrical connection by a qualified electrician.

### Window Size (safety glass)

19.5" wide (495 mm)  
 12.5" high (318 mm)

## MEDIA RECLAIMERS

### The Heart of ZERO's Blasting System

Our exclusive media reclaimers continuously extract dust and debris and return properly sized, usable media to the blast system. The standard reclaimer handles all non-metallic media. For metallic media, specify reduced ID conveying hose.

The suction blast metering valve is infinitely adjustable from fully-closed to wide open, and locks into any setting without tools.

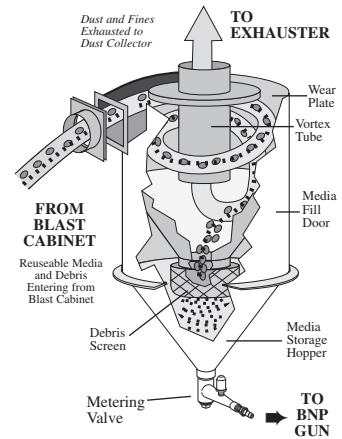

## BNP BLAST GUN

### AIR CONSUMPTION

BNP GUN	NOZZLE ORIFICE	AIR JET	CFM at 80 PSI	M <sup>3</sup> /Min at 5,5 BAR	MINIMUM RECLAIMER
No. 4	5/16"	1/8"	21	0,60	300 CFM (8,5 m <sup>3</sup> /m)
No. 5	5/16"	5/32"	32	0,90	300 CFM (8,5 m <sup>3</sup> /m)

MediPulse cabinet comes with a standard No. 5 ceramic nozzle. Optional tungsten and boron carbide lined nozzles available for use with aggressive media.

### Reclaimer Flow Rate

Nominal 300 cfm

## DUST COLLECTOR

Reverse pulse cartridge dust collector (which traps 99.7% of dust down to 0.5 micron) allows non-stop, high-production blasting. The polyester-cellulose cartridge is automatically pulse cleaned for maximum filter efficiency. Worn cartridge can be replaced in minutes.

### Filtering Area

195 ft<sup>2</sup> (18,1m<sup>2</sup>)

Dust concentration in exhausted air is nominally 5.0 mg/m<sup>3</sup>.

For especially dust sensitive work environments, order the optional HEPA filter.

Distributed By:

Clemco is committed to continuous product improvement. Specifications are subject to change without notice.

Clemco Industries is ISO 9001-2008 certified.