



★★★★  
MADE IN THE  
USA

# BNP DOUBLE 220 PRESSURE BLAST CABINET

TWO BLAST STATIONS PROVIDE EASY ACCESS TO LONG OR COMPLEX PARTS

**IMPORTANT:** For safe, efficient blasting, read and follow the operations manual and seek training for everyone who will use this equipment.



***For tough cleaning jobs, pressure blasting delivers higher abrasive velocity for greater impact intensity, compared to suction blasting, and can increase your production rate by as much as 300 percent.***

## SAFETY

- Full-length, neoprene-on-fabric gloves resist wear and protect operator.
- Safety interlocks interrupt blasting if either door is opened.

## PRODUCTIVITY

- Two stations for one blast operator provide easy access to blast from either station to accommodate large or complex parts. One nozzle and foot pedal are standard. For a cabinet equipped for two operators, contact your local distributor.
- High efficiency, 2.0 cubic foot capacity, ASME-coded pressure vessel, fitted with 1" ID piping, industrial-quality blast hose and couplings and cabinet integrated controls.
- Unique Air Logic system (pilot actuated) to maximize air flow to the nozzle.
- Ceiling-mounted, 50w LED light fixture with abrasive resistant Ocover for extraordinary visibility.
- 14-gauge steel all-welded construction, forms a rigid, long-lasting cabinet shell.

## CONVENIENCE

- Tilt-out window, for tool-free glass changes in minutes.
- Double-wall, sound-insulated doors on both ends, industrial-quality lift-off hinges.
- Pressure regulator, gauge, air and electric switch mounted within easy reach.
- Built-in blow-off gun helps keep dust inside the cabinet, not on your floor.

## COMMON APPLICATIONS

- Remove rust, mill scale, heat scale, and carbon buildup from metals.
- Strip paint, powder coating, plating, and anodizing from parts for rework.
- Eliminate burrs, reduce parting lines, remove flashings and other defects from castings and injection-molded parts.
- Extract residual sand from castings.
- Beautify steel, stainless steel, aluminum, brass and other metals with a uniform matte finish.
- Etch artwork and lettering into glass, stone, plastics, metal and other materials.
- Clean release agents and material buildup from molds.

## POPULAR ACCESSORIES

- A-300 automation kit
- Adjustable gun mount
- Adjustable vortex tube
- Air-powered vertical lift door
- Aloxx kit (for harsh media)
- Anti-fatigue mat
- Arm rest assembly
- Curtains (black or white)
- HEPA Filter
- Manometer kit
- Timed door release

## COMPLETE SYSTEM

Space required depends on configurations, options and work flow. Allow space for operator and maintenance access. See maintenance access height (MAH) below.

**Model illustrated:** BNP Dbl 220P-900 CDC-1, 900 CFM Reclaimer and CDC-1 collector.

### BNP DBL 220P

- A - 40.5 (1029 mm)
- B - 106" (2692 mm)
- C - 83.5" (2121 mm)

### CDC-1

- D - 42" (1067 mm)
- E - 34" (864 mm)
- F - 94" (2388 mm)

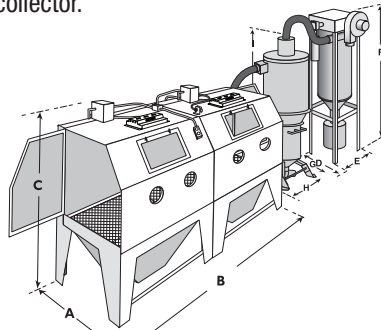

### Blast machine/900 cfm reclaim

- G - 34" deep (864 mm)
- H - 29" wide (737 mm)
- I - 96" high (2438 mm)

## CABINET

### Working Chamber

- 103" wide (2550 mm)
- 39" deep (991 mm)
- 43" high (1092 mm)

### Window (safety glass)

- 19.5" wide (495 mm)
- 12.5" high (318 mm)

### Door Opening

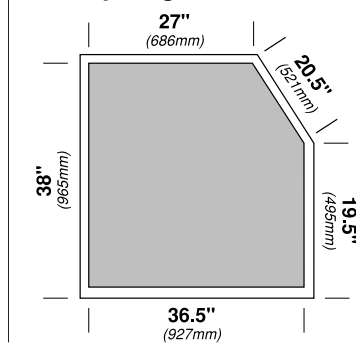

## BLAST RECLAIM SYSTEM

Our exclusive media reclaimers continuously extract dust and debris and return properly sized, usable media to the blast system. The standard reclaimer handles all non-metallic media. For metallic media, choose from the two PM models. The reclaimer, mounted atop the pressure vessel, automatically refills the blast system with clean, recycled media. The versatile design of our larger reclaimers lets you quickly adapt the system to your changing needs.

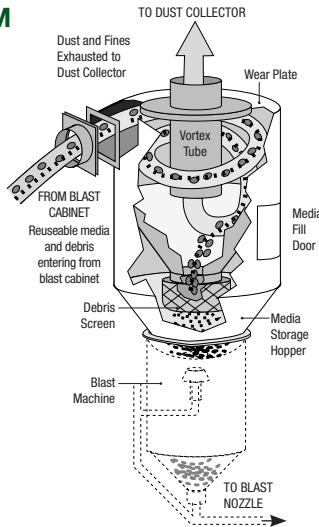

- 20" and 30" Dia. Turntables with or without work car and 9 foot track extension

## TUNGSTEN CARBIDE BLAST NOZZLE

The standard No 3 tungsten carbide nozzle is perfect for most blasting, while the optional boron carbide nozzles stand up to hundreds of hours of blasting with aluminum oxide or other aggressive abrasives.

## NOZZLES (AIR REQUIREMENTS)

Nozzle	Nozzle Orifice	CFM at 80 psi	M <sup>3</sup> /Min at 5,5 BAR	CFM at 100 psi	M <sup>3</sup> /Min at 7 BAR
No. 3	3/16"	38	1, 08	45	1, 3

BNP Double 220 pressure cabinets come with a No 3 tungsten carbide nozzle.

## METALLIC MEDIA

For steel media applications, the reclaimer, flex hose, and adaptors must be appropriately sized. Rubber curtains are recommended. "M" in cabinet model signifies cabinet is steel-ready (see below). Contact your local distributor for field conversion information.

## DUST COLLECTORS

**ZERO RP dust collectors trap 99.7% of dust particles down to 0.5 micron.**

**CDC-1:** CDC-1 dust collectors come in three sizes; 300 cfm, 600 cfm, and 900 cfm. The cartridges are pulse-cleaned by pressing the manual pulse valve to clear the filter of dust. Dimensions are 34" wide, 42" deep (with motor housing) and 94" high. The MAH is 11 ft for the 300 and 600 cfm units and 12-1/2 ft for the 900 cfm unit.

**RPH-2:** The RPH-2 has a filter area of 470 sq ft; the RPH-3 has a 705 sq ft filter area. Both have a built-in hopper to minimize dust-handling. At each pulse, dust falls first into the hopper and then into a disposal drum or bag beneath it. The operator never handles the dust—an important safety feature. RPH dust collector dimensions are: 56" wide (with motor housing) by 36" deep by 115" high. The RPH is designed to allow outdoor installation. The MAH for the RPH collectors is 15 ft 2 inch.

## ELECTRICAL

**900 CFM:** (25 m<sup>3</sup>/m) 2HP, 3PH, 60HZ (1.5KW, 220V, 3PH, 50HZ); available with three phase motors only, specify 230V or 460V.

## ORDERING INFORMATION

Model #	Reclaim CFM (m <sup>3</sup> /m)	Dust Coll.	Stock#	Ship Wt. lb(kg)
BNP-Dbl 220P-900 CDC	900(25)	CDC-1	28391	2,035(9232)
BNP-Dbl 220P-900 RPH	900(25)	RPH-2	21159	2,890(1311)
BNP Dbl 220PM-1200 RPH	1200(34)	RPH-3	27459	2,890(1311)