

MEDIA RECLAIMER/SEPARATOR



Clemco Industries Corp. • One Cable Car Drive • Washington, MO 63090
Phone: (636) 239-4300 • Fax: (800) 726-7559
Email: info@clemcoindustries.com
www.clemcoindustries.com

NOTICE TO PURCHASERS AND USERS OF OUR PRODUCTS AND THIS INFORMATIONAL MATERIAL

The products described in this material, and the information relating to those products, is intended for knowledgeable, experienced users of abrasive blasting equipment.

No representation is intended or made as to the suitability of the products described herein for any particular purpose of application. No representations are intended or made as to the efficiency, production rate, or the useful life of the products described herein. Any estimate regarding production rates or production finishes are the responsibility of the user and must be derived solely from the user's experience and expertise, and must not be based on information in this material.

The products described in this material may be combined by the user in a variety of ways for purposes determined solely by the user. No representations are intended or made as to the suitability or engineering balance of the combination of products determined by the user in his selection, nor as to the compliance with regulations or standard practice of such combinations of components or products.

It is the responsibility of the knowledgeable, experienced users of the products mentioned in this material to familiarize themselves with the appropriate laws, regulations and safe practices that apply to these products, equipment that is connected to these products, and materials that may be used with these products.

It is the responsibility of the user to insure that proper training of operators has been performed and a safe work environment is provided.

Our company is proud to provide a variety of products to the abrasive blasting industry, and we have confidence that the professionals in our industry will utilize their knowledge and expertise in the safe efficient use of these products.

OWNER'S MANUAL

1.0 INTRODUCTION

1.1 Scope of Manual

1.1.1 These instructions cover the installation, operation, maintenance, troubleshooting, and replacement parts for 900 cfm and larger reclaimers, used with blast cabinets and pneumatic recovery systems. Drawings supplied with the system's manual apply to the specific reclaimer provided. Use the drawings along with this manual, to aid in the assembly of the reclaimer and system. The reclaimer is one part of a media reclaiming and recovery system. Before putting the reclaimer into service, all personnel involved with the operation should read this manual, plus all accessory manuals.

1.2 Safety Alerts

1.2.1 Clemco uses safety alert signal words, based on ANSI Z535.4-1998, to alert the user of a potentially hazardous situation that may be encountered while operating this equipment. ANSI's definitions of the signal words are as follows:



This is the safety alert symbol. It is used to alert the user of this equipment of potential personal injury hazards.

Obey all safety messages that follow this symbol to avoid possible injury or death.

CAUTION

Caution used without the safety alert symbol indicates a potentially hazardous situation which, if not avoided, may result in property damage.

 **CAUTION**

Caution indicates a potentially hazardous situation which, if not avoided, may result in minor or moderate injury.

 **WARNING**

Warning indicates a potentially hazardous situation which, if not avoided, could result in death or serious injury.

 **DANGER**

Danger indicates an imminently hazardous situation which, if not avoided, will result in death or serious injury.

1.3 General Description

1.3.1 Reclaimers are divided into two primary categories: Push-thru and Pull-thru. Within those categories, the reclaimer is either a suction type or pressure type. Some of the smaller reclaimers are convertible. The operation of the reclaimer is the same for both types. Refer to Figure 1 for reclaimer type and components.

Suction type reclaimers are identified by the conical bottom, adapted for the attachment of BNP style media metering valve(s), or media valve manifold.

Pressure type reclaimers have a flanged, open bottom that bolts to a mating flange on a blast machine or storage hopper.

1.3.2 **Pull-thru:** Pull-thru reclaimers do not have an exhauster. They are used with powered (exhauster equipped) dust collectors. Pull-through reclaimers have an outlet pipe mounted on top of the reclaimer for the attachment of the flex hose or ducting, which lead to the dust collector inlet. The vacuum for a pull-through system is created by the exhauster assembly mounted on the clean-air side of the dust collector.

1.3.3 **Push-thru:** Exhauster mounted (push-thru) reclaimers have an exhauster assembly mounted on top of the reclaimer body. They are used with non-powered dust collectors (dry filter), cross-draft blast rooms, and in applications requiring a booster exhauster. A damper is attached to the exhauster outlet when an exhauster mounted reclaimer is used with a powered dust collector.

1.3.4 The bolt circle pattern on top of the reclaimer is the same for pull-through and push-through bodies. This allows for the conversion from one to the other.

1.4 Theory of Operation

1.4.1 The reclaimer is a cyclone separator, into which air, dust, fines, and by-products generated by the blasting process are drawn from a cabinet enclosure or blast room, for separation. Dust and fines are first separated from the reusable blast media. Next the media is screened of oversize particles, and returned to the reclaimer hopper for reuse. Air, dust and fines are drawn through the reclaimer into the dust collection system for disposal.

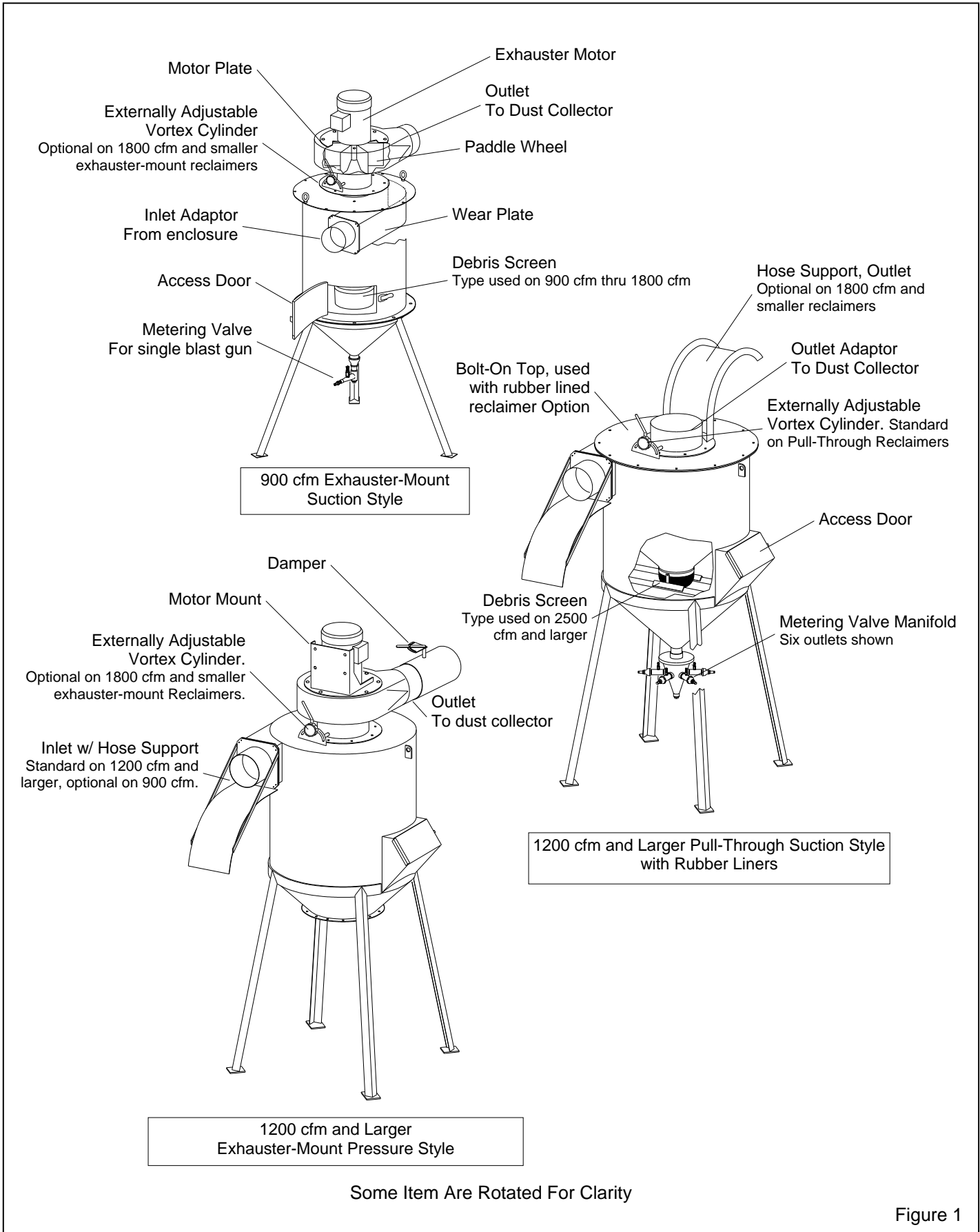

Figure 1

1.4.2 A constant static balance is necessary for efficient separation, as the reclaimer operates by a centrifugal balance of velocity, particle weight and size. The best way of ensuring a constant air balance is by setting, and monitoring static pressure with an optional manometer. See Section 9.1.

1.4.3 The size and style of the reclaimer is determined by the size of the enclosure, media size and weight, type of media, amount of media to be processed, and the type of dust collection system.

1.5 Wear Plate

1.5.1 A replaceable wear plate protects the reclaimer inlet area from rapid wear. The wear plate is standard on all non rubber lined reclaimers. See Figure 1.

1.6 Rubber Liners Option

1.6.1 Full, rubber lined reclaimers are recommended when using aggressive media. This option requires a reclaimer with a bolt-on top, and must be specified when the reclaimer is ordered.

1.7 Externally Adjusted Vortex Cylinder

1.7.1 The externally adjusted vortex cylinder is standard on 2500 cfm and larger exhaustor-mounted reclaimers, all job order reclaimers (built around user specifications), and all pull-through. It is optional on 1800 cfm and smaller exhaustor-mounted reclaimers.

1.7.2 The cylinder allows for fine tuning of the reclaimer. Refer to Section 5.2.

1.8 Blast Media

NOTE: This section applies to the reclaimer only. It does not address the limitations of other parts of a complete recovery system, such as blast room floors or cabinet hoppers. Any air restrictions external of the reclaimer will affect usable media size. Particular attention must be giving to all other components, especially when considering the use of heavy and/or aggressive media.

1.8.1 Selection of blast media can play a significant part in both the productivity and maintenance of the reclaimer. Most systems with pneumatic recovery use glass bead, manufactured media, or mineral media. **DO NOT USE abrasives containing more than one percent crystalline (free) silica. Obtain a material safety data sheet (MSDS) for the blast media.**

1.8.2 The reclaimer utilizes most common reusable media specifically manufactured for dry blasting or peening. The usable media size range depends on the recovery rate and reclaimer cleaning rate. Several factors affecting the reclaimer cleaning rate include: reclaimer size, media friability, contamination of parts being cleaned, and humidity. Media sizes shown under the media headings and in Figure 2 are guidelines only, based on average conditions.

1.8.3 Using media 200 mesh and finer, lightweight media such as plastic, or glass bead finer than No. 12, will usually require the removal of the inlet baffle, and the addition of the externally adjustable vortex cylinder.

1.8.4 Steel: Steel shot and steel grit are not recommended for use with reclaimers having a standard size inlet. 900 cfm and larger reclaimers may be used with steel media if the inlet hose diameter is reduced as shown in Figure 2. Conveying hose used with steel media should have a smooth durable lining. Reclaimers can be ordered from the factory with conveying hose appropriately sized for steel grit, or they may be converted at a later date.

1.8.5 Sand and Slag: Sand should never be used because of the respiratory hazards associated with the use of using media containing free silica. Slags are not recommended because they rapidly breakdown.

1.8.6 Silicon Carbide, Aluminum Oxide, and Garnet: These are the most aggressive, high volume abrasive in the blasting industry. Aggressive media such as these may be used with the reclaimer, but the service life will be reduced on any equipment components which come in contact with the abrasive. To avoid unscheduled down time, periodically inspect the reclaimer wear plate, reclaimer booster exhaustor and paddle wheel, reclaimer vortex tube, reclaimer inlet adapter, hoses, and nozzle for abrasive wear.

When occasionally using aggressive abrasive, install an optional aluminum oxide kit. When routinely using these media, use a fully rubber lined, pull through reclaimer and a reverse-pulse dust collector. Interior rubber linings on the blasting enclosures and a boron carbide nozzle are suggested to prolong service life.

1.8.7 Glass Bead: Most beads have been treated to ensure free-flow operation even under moderately high humidity conditions. Glass beads subjected to excessive moisture may be reused after thorough drying and breaking up of any lumps.

1.8.8 Fine-mesh Media: When using very fine media (200 mesh and finer, #13 glass bead, or lightweight

media), the inlet baffle of the reclaimer may need to be removed. Consult the factory before proceeding with this option. Reclaimers can be ordered from the factory without the inlet baffle. The adjustable vortex cylinder should be installed when using 200-mesh and finer media.

1.8.9 Lightweight Media: When using plastic media, and most agricultural media, the inlet baffle of the reclaimer may need to be removed. Consult the factory before proceeding with this option. Reclaimers can be ordered from the factory without the inlet baffle. The adjustable vortex cylinder should be installed when using lightweight media.

Media sizes shown below are guidelines only, and based on average conditions, such as contamination of parts being cleaned, humidity, media friability, reclaimer loading rate, etc. Any air restrictions external of the reclaimer will affect usable media size. Media finer than those shown may decrease visibility in the blast enclosure, and at some point carryover to the dust collector. Media coarser than those shown may be too large for the reclaimer to recover from the enclosure.

RECLAIMER SIZE	MEDIA TYPE				
	STEEL GRIT	STEEL SHOT	PLASTIC	GLASS BEAD	ALUM. OXIDE
900 cfm with 5" inlet	40 & finer	170 & finer	Do not use	Do not use	16 to 36
900 cfm with 6" inlet	Do not use	Do not use	*12 to 40	#6 to #12 * #13	46 to 200 * 220 to 320
1200 cfm with 6" inlet	40 & finer	170 & finer	Do not use	Do not use	16 to 60
1200 cfm with 7" inlet	Do not use	Do not use	*All sizes	#6 to #12 * #13	46 to 200 * 220 to 320
1800 cfm with 7" inlet	25 & finer	280 & finer	Do not use	Do not use	16 to 60
1800 cfm with 8" inlet	Do not use	Do not use	*All sizes	#6 to #12 * #13	46 to 200 * 220 to 320
2500 cfm with 8" inlet	25 & finer	280 & finer	Do not use	Do not use	16 to 60
2500 cfm with 10" inlet	Do not use	Do not use	*All sizes	#6 to #12 * #13	46 to 200 * 220 to 320
3200 cfm and larger	These reclaimers are furnished on job orders for specific media applications.				
Shaded lines represent reclaimers with reduced sized inlet					
Non shaded lines represent standard reclaimers					
* To utilize these size media baffle is removed from the reclaimer					

Figure 2

2.0 INSTALLATION

Installation Notes: The externally adjustable vortex cylinder and exhauster can be rotated, to align the reclaimer inlet, vortex adjustment handle, and exhauster outlet, to the most efficient positions. Determine the best location for all components, and position all segments before final assembly.

2.1 Placement

2.1.1 General arrangement drawings are provided on job orders (equipment built around user specifications). Place the reclaimer as close as possible to the orientation or as shown on the floor plan of those drawings.

2.1.2 Position the reclaimer to provide full access to load and unload media, and to service the vortex cylinder and metering valves. For optimum efficiency and the least amount of equipment wear, the reclaimer should be located directly behind, and as close as possible the cabinet or room enclosure.

2.1.3 Rotate the reclaimer, to enable connection of the inlet flex hose with as few bends as possible.

2.1.4 Rotate the externally adjustable vortex cylinder and exhauster, to align the vortex adjustment handle, and exhauster outlet, to the most efficient positions.

2.2 Assembly of Reclaimer on Pressure System

NOTE: The following instructions are for mounting smaller reclaimers over a storage hopper or blast machine. Most large reclaimers are furnished as job orders. For the placement and assembly of job order reclaimers, refer to the general assembly drawings that are included with these printed instructions.

2.2.1 Apply adhesive-backed strip gasket to the top of the flange on the blast machine or storage hopper. Punch out an opening at each bolt-hole.

2.2.2 Place the optional storage segment on the blast machine. The access door should be on the bottom, and rotated to allow access. Bolt into place. Apply adhesive backed gasket to the top flange per Section 2.2.1.

2.2.3 Using a lift, raise the reclaimer over the blast machine assembly, and lower it in place. Attach with fasteners provided.

 **WARNING**

Do not work under the reclaimer while it is hanging from the lifting device. Severe injury or death could occur if the reclaimer is released before it is secured to the blast machine.

2.2.4 Support the Blast Machine: Use ropes or other means to temporarily support the blast machine and reclaimer during final assembly.

2.2.5 When the equipment is permanently positioned bolt the blast machine to the floor. Anchor holes are located in the blast machine leg pads. Anchor through the holes to secure the machine to the floor. Larger reclaimers may need additional support from a point on the reclaimer to a near by fixed structure. Remove the temporary supports after the machine is secured.

2.3 Inlet and Outlet Connections

Flex Hose Installation Note: It is easier to slip the hose over the adaptor and to create a tighter seal if the first two or three inches of wire is removed from the inside of the hose. Use care not to damage the hose. The hose wire helps dissipate static electricity in the conveying hose, and helps ground each segment. In order for the hose wire to dissipate static electricity, the wire must touch the metal of each segment. Make sure each end is securely fastened with clamps to prevent media and dust from escaping.

2.3.1 Connect the appropriately sized flexible conveying hose or ducting from the recovery source (cabinet hopper transition, M-Section® transition, or wye pipe) and the reclaimer inlet adaptor, which is located at the upper side portion of the reclaimer. Clamp the flex hose securely with worm clamps provided.

2.3.2 Connect the appropriately sized flexible conveying hose or ducting from the reclaimer outlet, to the dust collector inlet. Refer to Figure 1.

2.4 Metering Valve Assembly, (suction systems only)

2.4.1 The type of metering valve feed system is determined by the number of blast guns. The illustration in Figure 3 shows several systems. When one blast gun is used, the metering valve is attached to the pipe nipple located on the bottom of the reclaimer hopper. If two guns are used, the first metering valve is installed as stated above, and the second valve is installed under it as shown. When more than two blast guns are used, a media manifold is attached to the bottom of the reclaimer, using the same amount of valves as blast guns. Marking each metering valve, hose and blast gun with a corresponding number makes adjustments and troubleshooting easier.

2.5 Electrical Wiring

 **WARNING**

Electrical power must be locked out and tagged out before continuing. Shorting electrical components could result in serious electrical shocks, or damage of equipment. All electrical work, or any work done inside an electrical panel, must be performed by a qualified electrician, and comply with applicable codes.

2.5.1 Voltage and motor horsepower depend on the size of the reclaimer. Unless specified otherwise, 2 hp and larger motors are 230/460 volt, 3 ph, 60 Hz. Wire the entire system according to wiring diagrams when diagrams are provided. Check the amperage on initial start up. If the motor draws excessive amperage, gradually close the damper until the amperage is within the specifications shown on the motor plate. The damper is located on the inlet of dry filters, and on the exhaust outlet of reverse-pulse collectors.

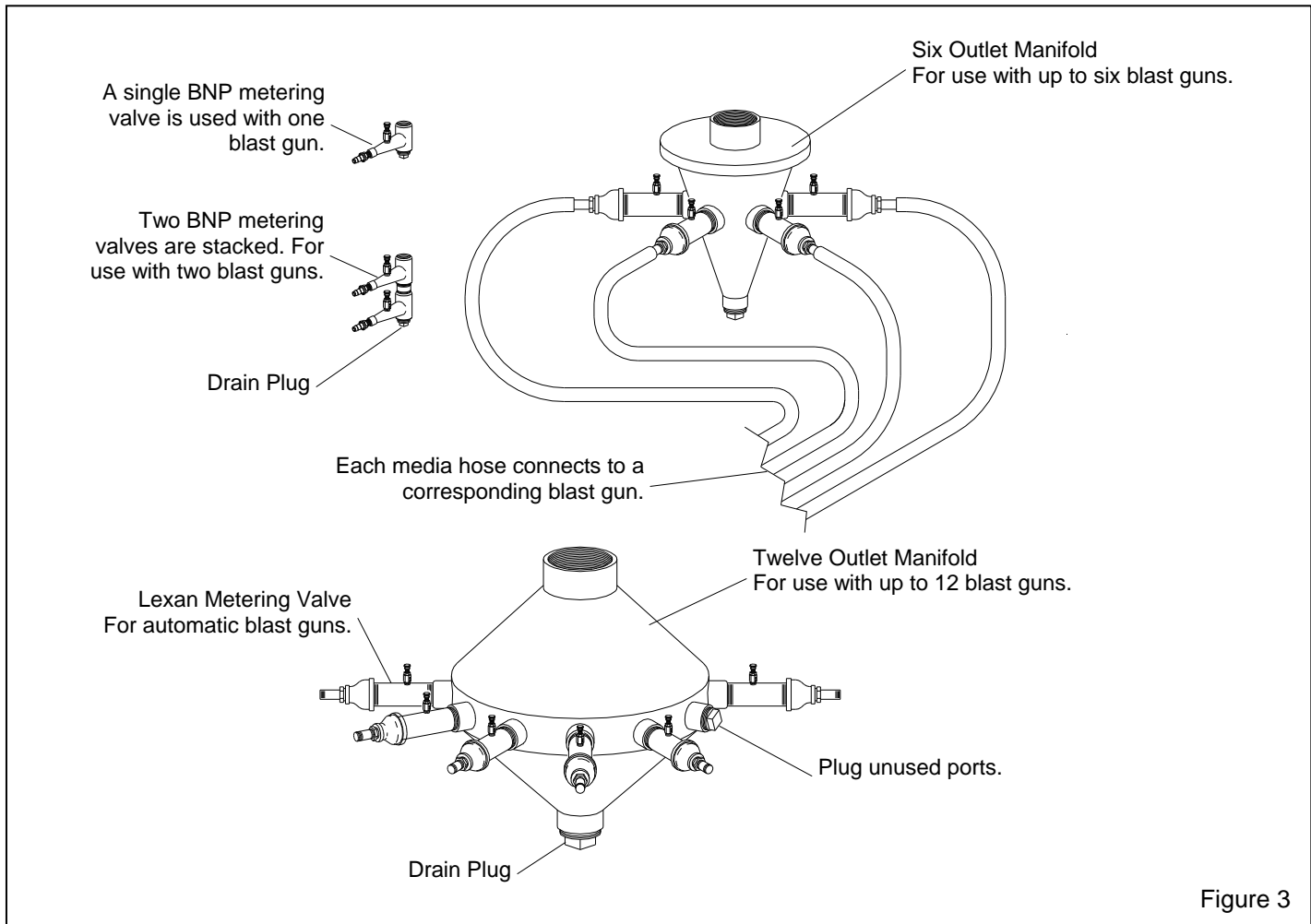

Figure 3

3.0 OPERATION

3.1 Media Loading and Unloading

3.1.1 Media Loading: With the exhauster off, add clean, dry media, by pouring it into the reclaimer hopper through the reclaimer door. Do not pour media directly into the cabinet hopper or room recovery hoppers, as overfilling may occur. Do not fill past the cone on the reclaimer. Overfilling will result in media carryover to the dust collector and possible blockage in the conveying hose. Underfilling will allow air to draw through the metering valve and feed assembly, and interfere with media flow. Refill only after all media has been recovered.

3.1.2 Media Unloading: To empty the reclaimer of media, allow all media to be recovered, turn off the exhauster, and place an empty container under the metering valve (or manifold). Unscrew the drain plug from the metering valve or manifold, permitting media to flow into the container. If media doesn't flow, it has

caked. Open the fill door and stir media until it starts to flow. Empty the container when full or before it is too heavy to handle, and repeat the process until the reclaimer is empty. Replace the plug when the reclaimer is empty.

4.0 OPTIONAL ACCESSORIES

4.1 Manometer

NOTE: The following instructions explain the use of the manometer for taking periodic static pressure readings on reclaimers. Refer to the enclosure instructions for using the manometer on cabinet enclosures. Permanent fittings should be installed when rigid ducting is used, or when the manometer installation is permanent. Use silicone sealer or other sealant to seal around the fitting to prevent leaks. The fitting should be capable of being capped when the manometer tube is removed, to prevent leaks.

4.1.1 The illustration in Figure 4 shows the manometer set-up for taking periodic static pressure readings on pull-through and push-through reclaimers. A permanent fitting can be installed in the reclaimer door frame, as shown, for frequent static pressure readings.

4.1.2 Refer to directions packed with the manometer for filling and operation instructions for the manometer.

4.1.3 Connect one end of the 3/16" ID tubing to the tubing adaptor on the manometer, by pushing it over the barbed fitting.

4.1.4 Leaving the needle protector on the needle, insert the needle into the other end of the tubing. The ends of the tubing must fit tight on the manometer and needle; leaks will give inaccurate readings.

4.1.5 Open both manometer valves (elbows) one full turn.

4.1.6 Magnets on the manometer hold it in position on the reclaimer body. The manometer must be vertically plumb so the fluid is level on both sides.

4.1.7 Adjust the slide rule to align the zero with the fluid level. See Figure 5.

4.1.8 Needle placement: Ref. Figure 4.

4.1.8.1 Pull-through system (reclaimer without exhauster): Remove the needle protector, and insert the needle into the flex hose approximately 8" from the top of the reclaimer.

4.1.8.2 Push-through system (reclaimer with exhauster): Open the reclaimer fill door, remove the needle protector and place the needle so the point is inside the door opening. Carefully close the door on the needle. The side of the needle will embed into the rubber, creating an airtight seal. Static pressure readings at the door are generally .5" to 1" lower than those taken above the reclaimer.

Readings on systems with no fill door (usually used with a classifier), may be taken at the flex hose connection under the reclaimer. Static pressure is generally .5" to 1" lower than that taken above the reclaimer.

Systems with airlocks, that prevent readings to be taken at the discharge to the reclaimer, may be taken at the reclaimer inlet. When the reclaimer is running to capacity, these readings are generally 1" to 2" lower than those taken at the reclaimer outlet.

4.1.9 Turn the exhauster ON. The negative (static) pressure will move fluid in the tube.

NOTE: Readings must be taken with the enclosure doors (cabinet or blast room) open, and with the exhauster running.

4.1.10 To find the static pressure, observe the fluid level in each column, above and below zero, (level line) and add the readings together. See the example in Figure 5.

4.1.11 After the readings are taken, replace the needle protector. Close the manometer valves and store the manometer in the original container in a clean area. Note: If the manometer installation is permanent, the manometer may remain on the reclaimer body after the valves are closed.

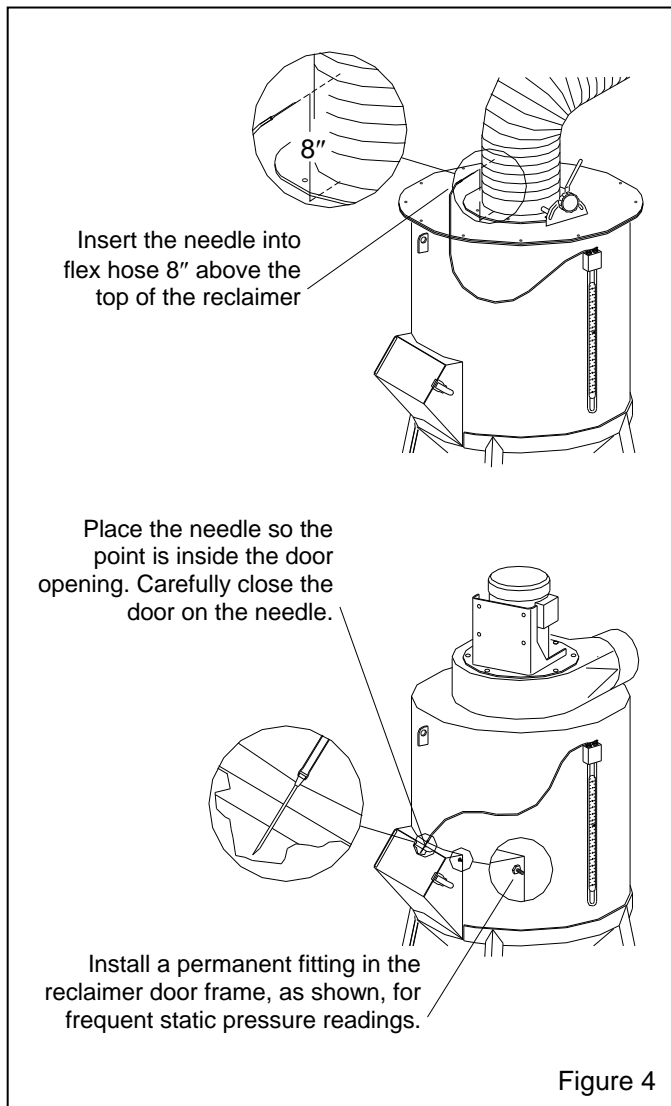

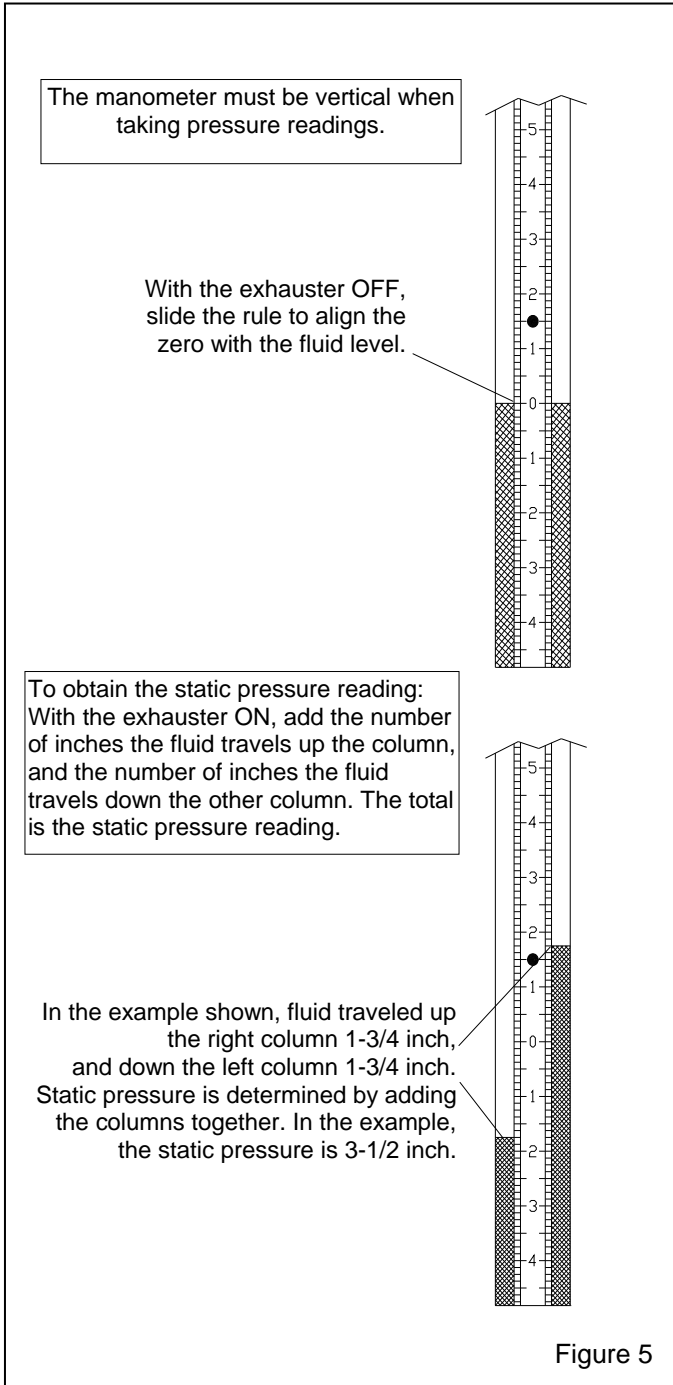

to establish static pressure starting point for given media.

Media	Size	Static Pressure
Glass Bead	8 to 13	2-1/2 to 3 inches
Al. Oxide	60 and coarser	4 to 5 inches
Al. Oxide	80 and finer	2-1/2 to 3 inches
Plastic	All *	2-1/2 to 3 inches
Steel Grit	**	6 to 7 inches

* Non Aerolyte reclaimers require modification. Consult the factory.

** Size is limited, and determined by the system's application.

Figure 6

5.1.2 Adjust static pressure by opening or closing the damper. The damper is located on the inlet of dry filters, and on the exhauster outlet of reverse-pulse collectors and reclaimers with a booster exhauster. Operate the system until the media has gone through several cycles before making additional adjustments. The objective is to obtain a balance of maximum dust removal without media carryover.

5.1.3 Dusty media: If the damper is not opened enough, the reclaimer will not remove fines, resulting in dusty media, poor visibility, and possible media blockage in the conveying hose. Open the damper enough to increase static pressure by 1/4 inch. After the media has gone through several cycles, check media and adjust the damper as required.

5.1.4 Media carryover: If the damper is opened too far, it may cause carryover (usable media carried into the dust collector) and result in excessive media consumption. Close the damper enough to decrease static pressure by 1/4 inch.

5.1.5 If the damper has been adjusted and carryover or excessive dust in the media continues to be a problem, adjusting the vortex cylinder may help retain media. The vortex cylinders do not usually require adjustment unless 200 mesh and finer media, or lightweight media is used. See Section 5.2 and 5.3, depending on the vortex cylinder option.

5.2 Externally Adjustable Vortex Cylinder (Standard 900 cfm and larger on job order reclaimers, and 2500 cfm and larger on standard, exhauster-mount reclaimers, and all pull-through reclaimers).

Note: Before adjusting the vortex cylinder, adjust the damper on the dust collector per Section 5.1. After the

5.0 ADJUSTMENTS

5.1 Static pressure

5.1.1 A manometer is useful when adjusting or monitoring static pressure. Manometers are listed under Optional Accessories in Section 9.1. Correct static pressure varies with the size of the reclaimer and the size, weight and type of media. Use the table in Figure 6

static pressure has been adjusted, adjust the cylinder as follows.

5.2.1 The adjusting lever for the vortex cylinder is mounted on the outlet pipe on top of the reclaimer or the spacer between the reclaimer body and exhauster housing depending upon which system is provided.

5.2.2 Adjustments are made by loosening the handle's locking knob and moving the handle to achieve the correct setting. When the correct setting is established, tighten the locking knob to prevent movement.

5.2.3 Start with the lever slightly to the right (about one o'clock) of the vertical position.

5.2.4 Dusty Media: To increase media consumption, raise the cylinder by moving the lever left toward "COARSE", in 1/4" increments at the indicator plate. Do not adjust again until the media has gone through several cycles, to be certain that further adjustment is required.

5.2.5 Media Carryover: To decrease media consumption (excessive usable media is being carried to the dust collector), lower the vortex cylinder by moving the lever right toward "FINE", in 1/4" increments at the indicator plate. Note: If the cylinder is lowered too far, the reclaimer will again begin to allow usable media to be carried over, and cause abnormally high static pressure.

5.2.6 When using very fine media (200 mesh and finer or plastic media), the inlet baffle of the reclaimer may also need to be removed. Consult the factory before proceeding with this option.

5.3 Internal Vortex Cylinder

Note: Before adjusting the vortex cylinder, adjust the damper per Section 5.1. After the static pressure has been adjusted, adjust the cylinder as follows.

5.3.1 Remove the flex hose from the outlet pipe or remove the exhauster assembly, depending on the reclaimer style.

5.3.2 The internal cylinder is visible by looking into the reclaimer from the top. The cylinder is held in position with three bolts.

5.3.3 Adjustments are made by loosening the bolts, and moving the cylinder up or down to achieve the correct setting. When the correct setting is established, tighten the bolts to prevent movement.

5.3.4 Start with overall length of the internal tube and cylinder, when measured from the top of the reclaimer to the bottom of the inner cylinder equaling the distance shown in Figure 7. If the reclaimer is rubber lined, add 1/4" to the starting point depth.

Reclaimer Size	Starting Point Depth
900 cfm	15 1/2 Inches
1200 cfm	18 1/2 Inches
1800 cfm	20 1/2 Inches
2500 cfm	22 1/2 Inches
3200 cfm	24 1/2 Inches
3600 cfm	25 1/2 Inches

Figure 7

5.3.5 Dusty Media: To increase media consumption, raise the cylinder in 1/4" increments. Do not adjust again until the media has gone through several cycles, to be certain that further adjustment is required.

5.3.6 Media Carryover: To decrease media consumption, lower the vortex cylinder in 1/4" increments. NOTE: If the cylinder is lowered too far, usable media will carryover, and cause abnormally high static pressure.

5.3.7 When using very fine media (200 mesh and finer or plastic media), the inlet baffle of the reclaimer may need to be removed. Consult the factory before proceeding with this option.

5.4 Metering Valve Adjustment, Figure 8

5.4.1 While blasting, check the media stream through the blast nozzle, or through each, clear, metering valve tube. With the correct media/air mixture, media will flow smoothly through the tube and nozzle.

5.4.2 If media does not flow smoothly, loosen the locking nut, and adjust the metering screw until the upper holes in the metering stem are closed-off, and the lower holes are fully open. See Figure 8. This adjustment is a starting point.

5.4.3 If pulsation occurs in the media hose, either media is damp and caked, or not enough air is entering the media stream. While blasting, loosen the locking nut and slowly turn the adjusting screw out (counterclockwise when viewed from the top) until the media flows smoothly. Tighten the locking nut finger-tight to maintain the setting.

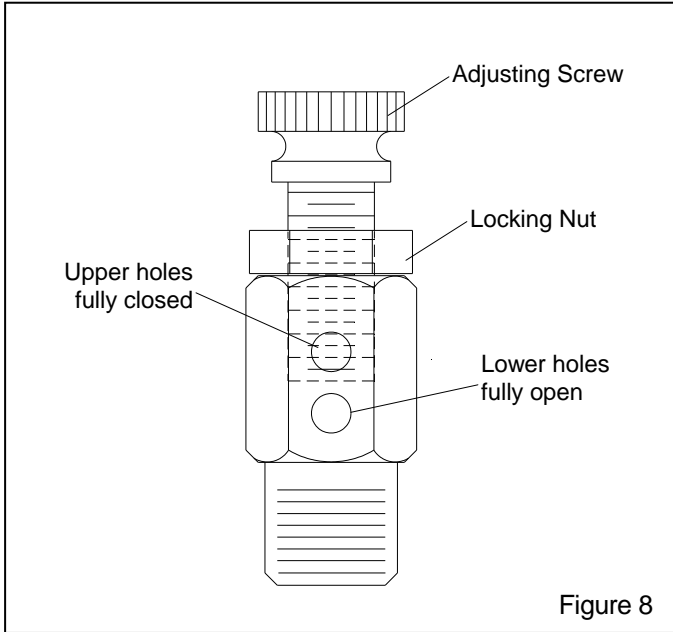

Figure 8

5.4.4 If media flow is too light, decrease air in the mixture by turning the metering screw in (clockwise when viewed from the top) covering more of the holes so less air enters the media hose. Tighten the locking nut finger-tight to maintain the setting.

6.0 PREVENTIVE MAINTENANCE

6.1 Clean the debris screen daily: To clean, turn the exhauster off, open the media fill door and remove screen. Empty the screen and replace it, making sure it is securely re-attached to the inner cone.

6.2 Check metering valves for obstructions: This is especially important on reclaimers used with automated shot peening equipment, where the nozzle flow may not be seen. Check flow through the clear, metering valve tube. Blockage occurs in this area if the debris screen is improperly installed or is detached, or when the metering valve needs adjusting.

6.3 Periodically check media hose for soft spots. Replace the hose as soon as soft spots are noted. Worn hose could collapse, and restrict media flow.

6.4 Periodically check the reclaimer inlet and outlet pipes, flex hose, and ducting for wear, and replace as required.

6.5 Check optional rubber liners. Replace liners when the rubber is worn-through.

7.0 SERVICE MAINTENANCE

7.1 Replacing Wear Plate

7.1.1 Remove the inlet adaptor and old wear plate. The wear plate is held in place by screws attached from the outside of the reclaimer.

7.1.2 Angle the new wear plate into reclaimer inlet until it is in position with the straight end at the reclaimer inlet. Using a board or similar object as leverage, pry the wear plate against the inner wall and top of the reclaimer, and install sheet metal screws to hold in place. Caulk any gaps or voids around the top of the wear plate to prevent rapid wear.

7.2 Replacing Optional Rubber Liners, Figure 9

Installation Note: When installing the liners, ensure that seams are aligned. The final assembly must be smooth and free of protrusions, edges, and gaps. Any edges will disrupt the air flow, causing wear, and affect the reclaimer's media cleaning efficiency.

7.2.1 Remove the inlet and outlet flex hoses.

7.2.2 Remove the bolts located next to the inlet adaptor that secure the end of the inlet baffle to the reclaimer weldment.

7.2.3 Remove the socket head screw that secures the inlet-top liner to the reclaimer top.

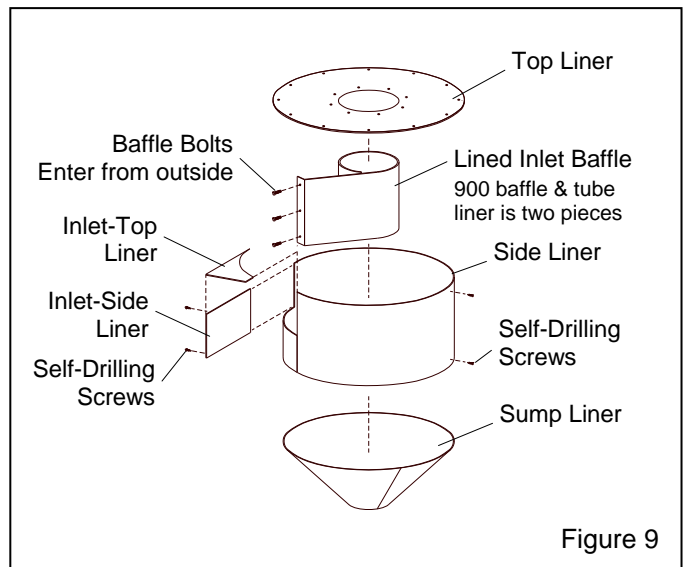

Figure 9

7.2.4 Remove the bolts securing the reclaimer top, and remove the top, along with the top liner and inlet baffle. NOTE: All but 900 reclaimer Inlet baffles are tack-welded to the inner tube. Before removing the baffle,

make an alignment mark along the reclaimer top (not the top liner) to ensure the new baffle will be correctly aligned. When replacing the baffle, align the baffle mounting holes, the side liner, the top liner, and the top. When aligned, mark each part, and tack the baffle tube to the inner tube. *NOTE: The baffle and tube on 900 reclaimers are two piece; the installation is covered in Paragraph 7.2.13.*

7.2.5 Inspect all the liners. Replace any that have worn through the rubber.

7.2.6 Side and inlet-side liners are held in place by self-drilling screws. From the outside of the reclaimer, remove the screws, and remove the liners.

7.2.7 The sump liner is glued to the cone with contact cement. Peel the old liner out and remove all residue from the cone.

7.2.8 Place the sump liner in the cone with the fabric side down, and check the fit. Apply medium-set contact cement, and install the sump liner.

7.2.9 Clamp the side liner in place, ensuring it is flush with the top of the reclaimer body and aligned with the inlet. Mark the side liner at the three bolt-hole locations for the inlet baffle. Remove the liner and drill the bolt holes. Reinstall the side liner. Align the three bolt-holes and temporarily place bolts through the holes to hold it in place. Clamp the liner, and while pushing the liner against the weldment, secure it with self-drilling screws, through each screw hole in the weldment.

7.2.10 Align the inlet-side liner and clamp it in place. Use self-drilling screw at each hole location in the weldment, to install the inlet liner.

7.2.11 Use silicone caulking to seal the seams all around the inlet-side liner and reclaimer weldment, between the inlet liner and side liner, and between the side liner and sump liner. Wipe the caulking smooth.

CAUTION

All seams between each liner must be sealed, and all seams between the liners and reclaimer weldment must be sealed. Voids will cause premature wear.

7.2.12 After the inlet baffle is aligned, and tacked to the inner tube (See Section 7.2.4), align the top liner and top, and apply caulking to the seam around the baffle and top liner. Refer to Paragraph 7.2.13 for 900 cfm reclaimers.

7.2.13 900 baffle and tube liner installation: Use worm clamps to clamp tube liner to the inner tube; align so seam is on the downward side of the baffle (between the baffle and reclaimer inlet.) tack the tube liner to inner tube at the bottom in three or four places. Apply caulking to the tube liner seam and the seam around the tube liner and top liner. Install the baffle, leaving the bolts somewhat loose.

7.2.14 Apply caulking around the top edge of the side liner and inlet liner, and install the top assembly. Secure the top bolts and inlet baffle bolts.

7.2.15 Working through the reclaimer inlet, wipe the caulking smooth. Apply additional caulking to seams between the baffle and side liner. Re-caulk any voids.

7.2.16 Install flex hoses.

7.2.17 Allow time for the caulking and sump liner cement to cure before putting the reclaimer in service.

8.0 TROUBLESHOOTING

8.1 Excessive Media Carryover

8.1.1 Dust collector damper open too far. Adjust static pressure per Section 5.1.

8.1.2 Vortex cylinder out of adjustment. Adjust vortex cylinder per Section 5.2 or 5.3, depending on the cylinder style.

8.1.3 Reclaimer door open or leaking. Check reclaimer door and gasket for leaks. Air entering the reclaimer at this point will cause media to be carried into the dust collector. DO NOT operate unless all doors are closed.

8.1.4 Leak in reclaimer weldment. Check entire reclaimer for leaks.

8.1.5 Media level too high. Do not fill past cone. Load media only through fill door.

8.1.6 Media level too low, causing air to be drawn in through metering valves. Check level and fill if low.

8.1.7 If using very fine media (200 mesh and finer), the inlet baffle of the reclaimer may need to be removed. Consult the factory before proceeding with this option.

8.1.8 Reclaimer debris screen clogged with debris. Check screen basket daily.

8.2 Reclaimer Not Recovering Media

8.2.1 Exhauster motor rotating backwards. The motor should rotate as indicated by the arrow on the exhauster housing. If it does not rotate in the proper direction, LOCK OUT AND TAG OUT ELECTRICAL POWER and switch the motor leads as shown on the motor plate. Refer to the system's wiring schematic.

8.2.2 Dust collector damper closed too far restricting air movement in cabinet. Adjust static pressure per Section 5.1.

8.2.3 Blocked air inlet duct in cabinet enclosure or blast room recovery segments. Blockage in the air intake ducts restricts incoming air and reduces air movement. Check for blockages

8.2.4 Hole worn in flex hose between cabinet or blast room recovery transitions and reclaimer inlet (if reverse-pulse collector is used, also check hose between the reclaimer outlet and dust collector inlet). Replace hoses and route it with as few bends as possible to prevent wear.

8.2.5 Reclaimer door open. DO NOT operate unless door is closed.

8.2.6 Obstruction in flex hose between cabinet or blast room recovery transitions and reclaimer inlet. Remove hose and check for blockage.

8.2.7 Exhauster paddle wheel worn. Check wheel for wear.

8.3 Excessively High Media Consumption

8.3.1 See Section 8.1

8.3.2 Media may be too fine or worn-out. Replace media as necessary.

8.3.3 Using media that rapidly breaks down. If the application allows for it, change to durable media.

8.3.4 Blast pressure too high for the media, causing media to breakdown. Lower blast pressure if application allows it.

8.4 Reduction in Blast Cleaning Rate

8.4.1 Low media level reducing media flow. Check level and fill if low.

8.4.2 Incorrect metering valve adjustment. Adjust metering valve air mixture per Section 5.4.

8.4.3 Reduced air pressure. This may be caused by a malfunctioning regulator, a dirty filter element in moisture separator, partially closed air supply valve, leaking air line, or other air tools in use.

8.4.4 Blockage in media hose or blast gun. Blockage may occur as a result of a missing debris screen or incorrect metering valve adjustment permitting heavy media flow. See Section 5.4.

8.4.5 Worn blast gun parts. Inspect gun body, nozzle, and air jet. Refer to the appropriate parts list, and replace all worn parts.

8.4.6 Worn media hose. Check hose for leaks and soft spots. Replace worn or damaged hose.

8.4.7 Air jet in gun out of adjustment. Refer to blast equipment instructions to check adjustment.

8.4.8 Moist media. Frequent bridges or blockage in the area of the metering valve can be caused by moisture. See Section 8.6.

8.5 Plugged Blast Nozzle

8.5.1 Damaged or missing debris screen. When the filter screen is damaged or not in place, all media and blast cleaning by-products, such as paint chips, scale etc. pass directly into the metering valve area, blocking the metering valve or nozzle. Check placement of the debris screen.

8.5.2 Media mixture too rich. Adjust media metering valve air mixture per Section 5.4.

8.6 Media Bridging

8.6.1 Frequent bridging or blockages in the media metering valve can be caused by damp media. Media becomes damp by blasting parts that are slightly oily, from moisture in the compressed air line, or from absorption.

8.6.2 To avoid contaminating media from the workpiece, all parts put into the cabinet should be clean and dry. If parts are oily or greasy, degrease and dry them prior to blasting.

8.6.3 Moist compressed air may be due to a faulty compressor that overheats or pumps oil or moisture into the air line, too long an air line permitting moisture to condense on the inside, or from humidity. Drain the moisture separator and receiver tank regularly. If the problem persists, it may be necessary to change media more often or install an aftercooler or air dryer.

8.6.4 Absorption: Some media tends to absorb moisture from the air, especially fine-mesh media in high humidity areas. Empty the media and store it in an airtight container when cabinet is not in use.

8.6.5 A vibrator attached to the reclaimer cone or media metering valve may help prevent bridging of fine-mesh media.

8.7 Blockage in Media Hose

8.7.1 Media obstructions. Usually caused when the media mixture is too rich. Adjust the metering valve air mixture per Section 5.4.

8.7.2 Wet or damp media. See Section 8.6.

8.7.3 Reclaimer debris screen clogged with debris. Check screen basket daily.

8.8 Media Surge

8.8.1 Heavy media flow. Adjust the metering valve air mixture per Section 5.4.

8.9 Dust not separating from media

8.9.1 Dust collector damper not open enough. Adjust static pressure per Section 5.1.

8.9.2 Vortex cylinder out of adjustment. Adjust vortex cylinder per Section 5.2.

8.9.3 Exhauster motor rotating backwards. The motor should rotate as indicated by the arrow on the exhauster housing. If it does not rotate in the proper direction, LOCKOUT AND TAGOUT ELECTRICAL POWER and switch the motor leads as shown on the motor plate. Refer to the system's wiring schematic.

9.0 REPLACEMENT PARTS

When ordering replacement parts for equipment built and sold on Job Orders, include the job order number, stock number, description, and drawing number.

3200 cfm and larger reclaimers are furnished on job orders; refer to the assembly drawings furnished with the equipment for replacement parts for those reclaimers.

9.1 Optional Accessories

Item	Description	Stock No.
(-)	Manometer kit	12528

9.2 Replacement Reclaimer Assemblies

Any reclaimers not listed are normally furnished on job orders. Refer to the job order manual furnished with the equipment for the replacement reclaimer assembly.

Item	Description	Stock No.
(-)	Reclaimer body assembly, less exhauster	
	Suction type	
	900 cfm	12399
	1200 cfm	24059
	1800 cfm	14152
	2500 cfm	14153
	Pressure type	
	900 cfm, for 14" blast machine	21193
	900 cfm, for 16" blast machine	21252
	900 cfm, for 24" blast machine	21823
	1200 cfm, for 16", 2 cf blast mach.	24068
	1200 cfm, for 16", 2 cf Aerolyte mach.	24069
	1200 cfm, for 24" blast machine	24062
	1800 cfm for 24" blast machine	25010
(-)	Reclaimer assembly, w/ exhauster	
	Suction type	
	900 cfm, 2 HP	12398
	1200 cfm, 5 HP	24058
	1800 cfm, 7.5 HP	14155
	2500 cfm, 10 HP	14154
	Pressure type	
	900 cfm, for 14" blast machine	21194
	900 cfm, for 16" blast machine	21253
	1200 cfm, for 16", 2 cf blast mach.	24064
	1200 cfm, for 16", 2 cf Aerolyte mach.	24065
	1200 cfm, for 24" blast machine	24061
(-)	Reclaimer assembly, pull-through	
	Suction type	
	900 cfm	21305
	1200 cfm	24060
	1800 cfm	21307
	Pressure type	
	900 cfm, for 16" blast machine	21293
	900 cfm, for 24" blast machine	24206
	1200 cfm, for 16", 2 cf blast mach.	24066
	1200 cfm, for 16", 2 cf Aerolyte mach.	24067

9.3 Exhauster Assembly, Figure 10

Item	Description	Stock No.
1.	Motor	
	900 cfm, 2 HP, 3 PH	12309
	1200 cfm, 5 HP, 3 PH	19156
	1800 cfm, 7.5 HP, 3 PH	12761
	2500 cfm, 10 HP, 3 PH	19169
2.	Mount, motor	
	900 cfm, plate, 2 HP	12005
	1200 cfm, 5 HP	17030
	1200/1800 cfm 7.5 HP	12002
	2500 cfm, 10 HP	17669
3.	Housing, exhauster	
	900 cfm	12271
	1200 & 1800 cfm	12270
	2500 cfm	12274
4.	Paddle wheel	
	900 cfm, 2 HP	12335
	1200 cfm, 5 HP	17617
	1200/1800 cfm, 7.5 HP	12336
	2500 cfm, 10 HP	17671
5.	Gasket, 5/16" x 1" adhesive backed, specify ft. required	00187

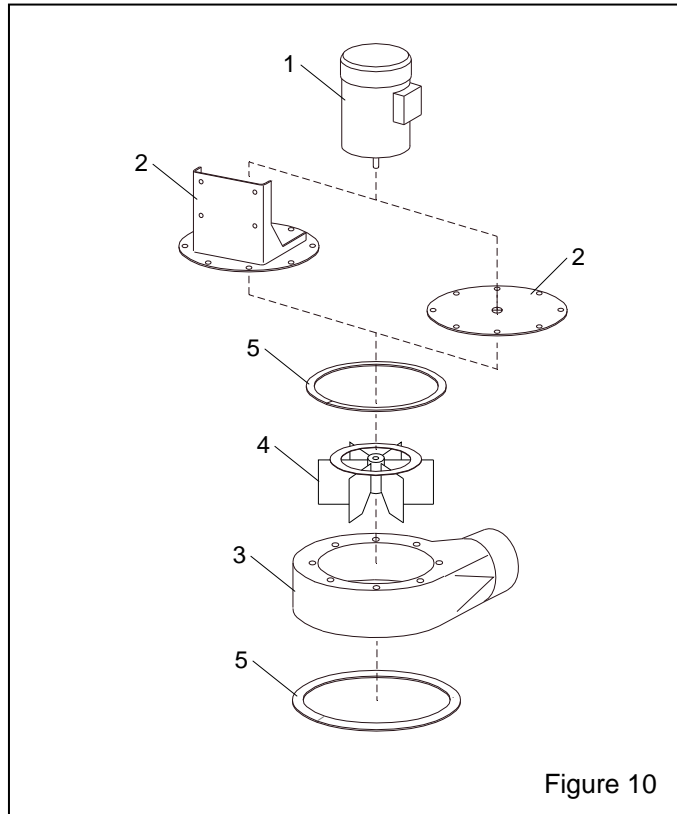

Figure 10

9.4 Rubber Liners, Figure 11

Reclaimer must be designed for liners and have a removable top.

Item	Description	Stock No.
(-)	Rubber liner sets	
	900 cfm	23151
	1200 cfm	23152
	1800 cfm	23153
	2500 cfm	23154
1.	Top liner	
	900 cfm	23059
	1200 cfm	22689
	1800 cfm	22695
	2500 cfm	22700
2.	Baffle, lined	
	900 cfm (2-piece)	23416
	1200 cfm	22691
	1800 cfm	22696
	2500 cfm	22701
3.	Side liner, reclaimer body	
	900 cfm	17008
	1200 cfm	22692
	1800 cfm	22697
	2500 cfm	22702
4.	Inlet side liner	
	900 cfm	12830
	1200 cfm	22693
	1800 cfm	22698
	2500 cfm	22703
5.	Sump liner	
	900 cfm	16070
	1200 cfm	22694
	1800 cfm	22699
	2500 cfm	22704
6.	Inlet top	
	900 cfm	22827
	1200 cfm	24031
	1800 cfm	24032
	2500 cfm	24033
7.	Screw, self drilling, 10-16 x 3/4"	12722

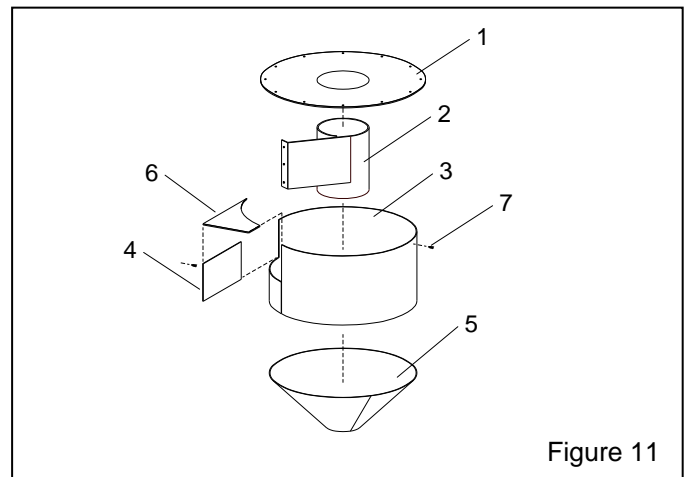

Figure 11

9.5 Reclaimer Parts, Figure 12

Item	Description	Stock No.
1.	Inlet pipe adaptor 900 cfm, 6" less support (standard)	12363
	900 cfm, 6" with support (option)	16887
	1200 cfm, 7" (standard)	20596
	1200 cfm, 6" (option)	22729
	1800 cfm, 8"	20597
	2500 cfm, 10"	20598
2.	Gasket, inlet adaptor 900 cfm	11759
	1200 cfm	11767
	1800 cfm	11765
	2500 cfm	11768
3.	Wear plate, field installed 900 cfm for reclaimers with solid top	14055
	for reclaimers with removable top	25071
	1200 cfm	19223
	1800 cfm	23028
	2500 cfm	23029
4.	Gasket, 5/16" x 1" adhesive backed, specify ft. required	00187
5.	Gasket, door 900 cfm	11745
	1200, 1800 and 2500 cfm	11766
6.	Screen assembly Standard mesh for 900, 1200, and 1800 cfm	21265
	for 2500 cfm	21272
	4.5 mesh Aerolyte for 900, 1200, and 1800 cfm	21275
7.	Spring latch assembly	12263
8.	Vortex assembly, externally adjustable, for exhauster mounted reclaimer 900 cfm, optional	23047
	1200 cfm, optional	19068
	1800 cfm, optional	19072
	2500 cfm, standard	19075
9.	Vortex assembly, externally adjustable, for pull-through reclaimer 900 cfm	23046
	1200 cfm	19087
	1800 cfm	19090
	2500 cfm	19093
10.	Hose support, outlet, pull-through 900 cfm, optional	20619
	1200/1800 cfm, optional	20730
	2500 cfm, standard	20731
11.	Gasket, 1/8" x 2" adhesive backed, specify ft. required	13089

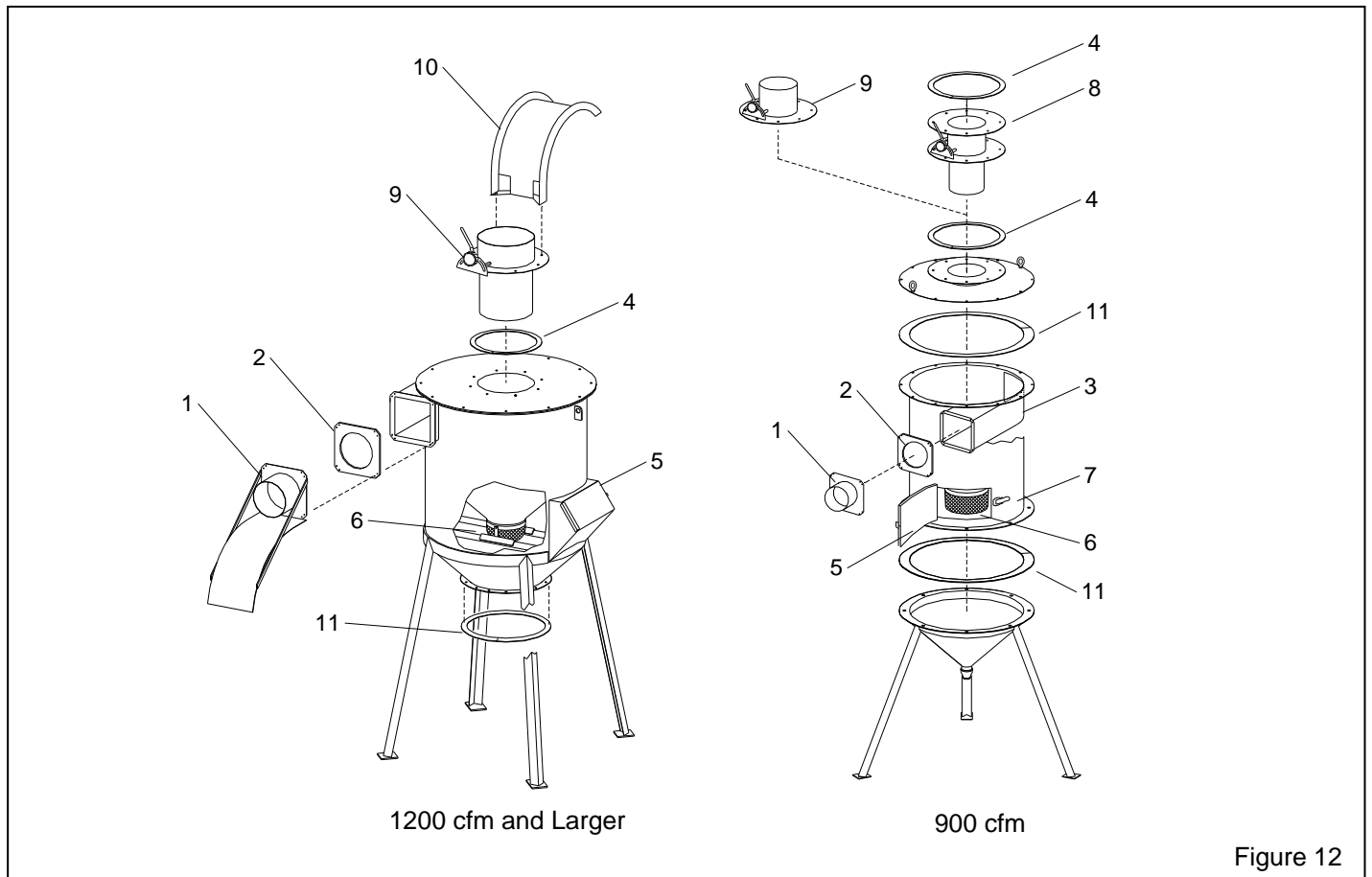

Figure 12

9.6 Metering Assemblies, Suction Systems
Figure 13

Item	Description	Stock No.
1.	Metering valve assembly, BNP	12417
2.	Stem, metering adjusting	23097
3.	Screw, adjusting	23098
4.	Nut, adjusting stem lock	23099
5.	Plug, 1" plastic	12011
6.	Fitting, hose, 3/8" NPT x 1/2" barb	06369
7.	Nipple 1" x close	01701
8.	Metering valve assembly, Lexan	12420
9.	Manifold, multiple metering valve, 2" inlet for use with up to 6 blast guns	12322
10.	Manifold, multiple metering valve, 3" inlet for use with up to 12 blast guns	16202
11.	Metering stem assembly (items 2, 3, & 4) .	23889

