

BNP 55

Suction Blast Cabinet



Clemco Industries Corp. • One Cable Car Drive • Washington, MO 63090
Phone: (636) 239-4300 • FAX (800) 726-7559
Email: info@clemcoindustries.com
www.clemcoindustries.com

NOTICE TO PURCHASERS AND USERS OF OUR PRODUCTS AND THIS INFORMATIONAL MATERIAL

The products described in this material, and the information relating to those products, is intended for knowledgeable, experienced users of abrasive blasting equipment.

No representation is intended or made as to the suitability of the products described herein for any particular purpose or application. No representations are intended or made as to the efficiency, production rate, or the useful life of the products described herein. Any estimate regarding production rates or production finishes are the responsibility of the user and must be derived solely from the user's experience and expertise, and must not be based on information in this material.

The products described in this material may be combined by the user in a variety of ways for purposes determined solely by the user. No representations are intended or made as to the suitability or engineering balance of the combination of products determined by the user in his selection, nor as to the compliance with regulations or standard practice of such combinations of components or products.

It is the responsibility of the knowledgeable, experienced users of the products mentioned in this material to familiarize themselves with the appropriate laws, regulations and safe practices that apply to these products, equipment that is connected to these products, and materials that may be used with these products.

It is the responsibility of the user to ensure that proper training of operators has been performed and a safe work environment is provided.

Our company is proud to provide a variety of products to the abrasive blasting industry, and we have confidence that the professionals in our industry will utilize their knowledge and expertise in the safe efficient use of these products.

OWNER'S MANUAL

1.0 INTRODUCTION

1.1 Scope of Manual

1.1.1 These instructions cover set-up, operation, maintenance, troubleshooting, optional accessories, and replacement parts for BNP 55 series suction blast cabinets, with all reclaimer and push-through dust collector options. A supplemental manual is provided for the optional reverse-pulse dust collector.

1.1.2 These instructions also contain important information required for safe operation of the cabinet. Before using this equipment, all personnel associated with the blast cabinet operation must read this entire manual, and all accessory manuals to become familiar with the operation, parts and terminology.

1.2 Safety Alerts

1.2.1 Clemco uses safety alert signal words, based on ANSI Z535.4-1998, to alert the user of a potentially hazardous situation that may be encountered while operating this equipment. ANSI's definitions of the signal words are as follows:



This is the safety alert symbol. It is used to alert the user of this equipment of potential personal injury hazards.

Obey all safety messages that follow this symbol to avoid possible injury or death.

CAUTION

Caution used without the safety alert symbol indicates a potentially hazardous situation which, if not avoided, may result in property damage.

CAUTION

Caution indicates a potentially hazardous situation which, if not avoided, may result in minor or moderate injury.

WARNING

Warning indicates a potentially hazardous situation which, if not avoided, could result in death or serious injury.

DANGER

Danger indicates an imminently hazardous situation which, if not avoided, will result in death or serious injury.

1.3 General Description

1.3.1 BNP blast cabinets enclose the blasting environment to provide efficient blast cleaning while maintaining a clean surrounding work area. Production rates are influenced by size of nozzle, compressor output, working pressure, type and size of media, angle and distance of the nozzle from the blast surface. BNP suction cabinets consist of three major components:

1. Cabinet Enclosure
2. Reclaimer
3. Dust Collector

See Figure 1 for arrangement of components with a dry filter. Figure 2 shows the arrangement with a reverse-pulse dust collector.

1.4 Theory of Operation

1.4.1 When the air supply is on, and the cabinet doors are closed, the cabinet is ready for operation by actuation of the foot pedal. Fully depressing the foot pedal causes air to flow through the blast gun. Air moving through the gun draws media into the blast gun mixing chamber. The media mixes with the air and is propelled out the nozzle. After striking the object being blasted, the blast media, along with fines, dust, and by-products generated by blasting, fall through the mesh work table into the cabinet hopper. These particles are drawn into the reclaimer for separation. Dust and fines are first separated from the reusable blast media. Next the media is screened of oversize particles, and returned to the reclaimer hopper for reuse. Dust and fines are drawn through the reclaimer into the dry filter or dust collector, which traps the dust and discharges clean air. When the foot pedal is released, blasting stops.

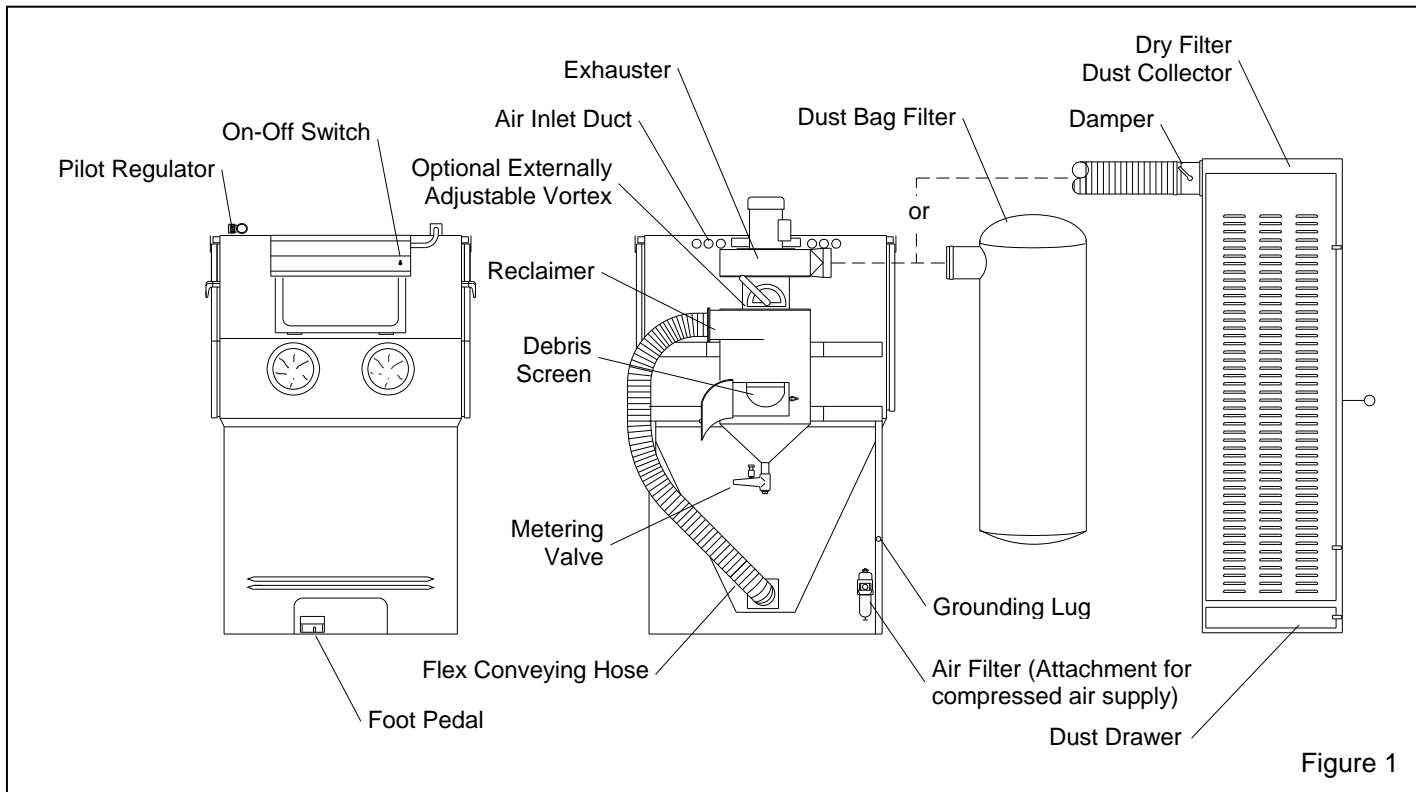

Figure 1

1.5 Dust Collector Options

⚠ WARNING

Prolonged exposure to any dust could result in serious lung disease and death. Short term ingestion of toxic materials, such as lead dust or dust from other heavy metals and corrosives, could cause serious respiratory injury or death. Identify all materials that are to be removed by blasting. Use reverse-pulse dust collectors with HEPA after-filters if lead coating or any other toxic materials are being removed by the blasting process. Do not use dust collectors with simple cloth filters for those applications.

1.5.1 Dust Bag: A dust bag, available on 300 and 600 cfm models, mounts on the reclaimer outlet. It is a single filter bag which collects dust on its inner surface. Dust bags perform adequately for occasional cabinet use. The bag must be emptied frequently. This type of dust collection must never be used in applications which generate toxic dust.

1.5.2 Dry Filter: A push-through dry filter uses tubular filters which trap dust on their inner surfaces. A dry filter is efficient for use with moderate dust contamination. The filters must be shaken manually every two hours

and the dust drawer emptied regularly. This type of dust collection must never be used in applications which generate toxic dust.

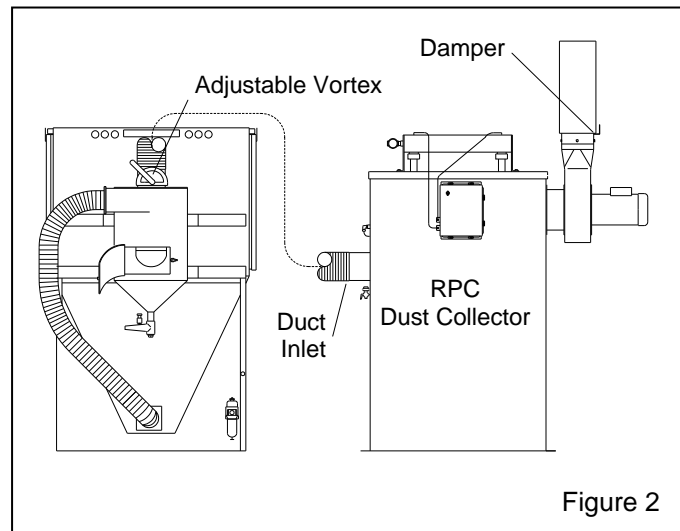

Figure 2

1.5.3 Reverse Pulse Dust Collector: A pull-through reverse-pulse dust collector is the most efficient dust collector option. Cartridge filters are automatically cleaned by a periodic pulse of compressed air. This type of dust collector used with the optional HEPA filter must be used in applications in which toxic dust is generated. See separate manual for operation of reverse-pulse dust collectors.

1.5.4 HEPA Filter: HEPA filters and reverse pulse cartridge collectors must be used when removing lead coatings or any other toxic materials. Optional HEPA after-filters provide additional filtration, and are available for use with a reverse-pulse collector.

1.6 Nozzle Options

1.6.1 Unless otherwise specified at the time of order, cabinets are shipped with a 5/16" orifice ceramic nozzle and No. 5 (5/32" orifice) air jet. Optional, more durable tungsten carbide and boron carbide nozzles are available and are shown under Accessories and Replacement Parts in Sections 9.1 and 9.3. Use boron carbide nozzles when blasting with aggressive media.

1.7 Media

1.7.1 BNP Suction Blast Cabinets utilize most common reusable media 25 mesh and finer, that is specifically manufactured for dry blasting. The usable media size range depends on the nozzle orifice size and reclaimer cleaning rate. Several factors affecting the reclaimer cleaning rate include: reclaimer size, air pressure, media/air mixture, media friability, contamination of parts being cleaned, and humidity. Media sizes noted are guidelines only, and are based on standard (5/16" orifice) nozzle (5/32" air jet) and average conditions.

As a rule, larger nozzles deliver more media, thus demand higher reclaimer cleaning rates. With larger nozzles, the maximum media size decreases from those recommended. Media finer than those recommended may decrease visibility, and increase carryover to the dust collector. Using media 200 mesh and finer will usually require the addition of the optional, externally adjustable vortex cylinder. See Section 5.5. The vortex cylinder is standard on pull-through systems (cabinets with reverse-pulse dust collectors). Media coarser than those recommended may be too dense for the reclaimer to recover from the cabinet hopper.

1.7.2 Steel: Steel grit or shot should not be used with the BNP-55 Cabinet. The cabinet is too small to prevent peening of the cabinet weldment, and 300 and 600 cfm reclaimers are too small to efficiently convey metallic media.

1.7.3 Sand and Slag: Sand should never be used because of the hazards of using media containing free silica. Slags are not recommended because they rapidly break down.

1.7.4 Silicon Carbide, Aluminum Oxide, and Garnet: These are the most aggressive, high-volume abrasives in the blasting industry. Aggressive media such as these may be used, but the service life will be reduced on any equipment components which come in contact with the abrasive. To avoid unscheduled down time, periodically inspect the reclaimer wear plate, exhauster housing and paddle wheel, hoses, and nozzle for abrasive wear.

When occasionally using aggressive abrasive, install an optional aluminum oxide kit. When routinely using these media, use a fully-rubber-lined reclaimer, a reverse-pulse dust collector, rubber curtains on the cabinet interior and a boron carbide nozzle to prolong service life. See Optional Accessories in Section 9.1.

1.7.5 Glass Bead: Most beads are treated to ensure free-flow operation even under moderately high humidity conditions. Glass beads subjected to excessive moisture may be reused after thorough drying and breaking up of any lumps.

1.7.6 Fine-mesh Media: The optional adjustable vortex cylinder should be installed when using 200-mesh and finer media. NOTE: The adjustable vortex cylinder is standard on pull-through systems (cabinets with reverse-pulse dust collectors). When using very fine media (200 mesh and finer), the inlet baffle of the reclaimer may also need to be removed. Consult the factory before proceeding with this option.

1.7.7 Lightweight Media: The optional adjustable vortex cylinder should be installed when using all plastic media and most agricultural media. NOTE: The adjustable vortex cylinder is standard on pull-through systems (cabinets with reverse-pulse dust collectors).

1.8 Compressed Air Requirements

1.8.1 The size of the compressor required to operate the cabinet depends on the size of the air jet and blasting pressure. Unless specified otherwise, cabinets are supplied with a No. 5 (5/32" orifice) jet. See table in Figure 3 to determine cfm requirements. Consult with a compressor supplier for suggested compressor size based on the air consumption.

NOTE: A separate air line is required for the optional reverse pulse dust collector.

Air Consumption in cfm

BNP Gun	Jet	Nozzle	CFM	PSI
No. 4	1/8"	5/16"	21	80
No. 5	5/32"	5/16"	32	80
No. 6	3/16"	3/8"	47	80
* No. 7	7/32"	7/16"	62	80
* No. 8	1/4"	1/2"	86	80

* Using this combination of jet and nozzle in applications that produce excessive dust may cause poor visibility.

Figure 3

1.8.2 The air filter at the air inlet connection, reduces condensed water from the compressed air. Its use is especially important in areas of high humidity, or when fine-mesh media are used. Moisture causes media to clump and inhibits free flow through the feed assembly. If moisture problems persist, an air dryer may be required.

1.9 Electrical Requirements

1.9.1 Electrical requirements depend on the size and phase of the motor. Standard cabinets are supplied as follows:

300 cfm reclaimer:

1/2 HP, 115/230V, 1-PH, 60 HZ (wired 115)

600 cfm reclaimer:

1 HP, 115/230V, 1-PH, 60 HZ (wired 115)

1.9.2 If voltage is 115, 1-phase, a power cord is supplied. If voltage is 230/460, 3-phase, there will be a magnetic starter mounted in an electrical panel (wiring schematics are packed in the panels). Power from the user's disconnect has to be wired to it. Additional wiring information is in Section 2.0.

2.0 INSTALLATION

2.1 General Installation Notes

2.1.1 Place all components in a convenient location where compressed air and electrical service are available. The cabinet location must comply with OSHA and local safety codes. Allow for full access to all doors and service areas and for efficient handling of parts. Make sure there is room to load media and to remove spent media. Determine the best location, and position all units before final assembly.

2.2 Connect Conveying Hose

2.2.1 Connect flexible conveying hose between the cabinet hopper transition and reclaimer inlet adaptor. It is easier to slip the hose over the adaptors and create a tighter seal if the first two or three inches of wire are removed from the inside of the hose. Use care not to damage the hose. Clamp flex hose securely in position with worm clamps provided. NOTE: The hose wire helps dissipate static electricity in the conveying hose, and also helps ground each segment. In order for the hose wire to dissipate static electricity, the wire must touch the metal of each segment.

2.3 Connect Compressed Air Supply Line(s)

WARNING

Failure to observe the following before connecting the equipment to the compressed air source could cause serious injury or death from the sudden release of compressed air.

- Lockout and Tagout the compressed air supply.
- Bleed the compressed air supply line.

WARNING

To avoid the risk of injury from compressed air, install an isolation valve and bleed-off valve where the air supply it tapped into the compressed air system. An ideal location is on the wall within sight of the cabinet. This enables depressurization of the compressed air line before performing maintenance.

2.3.1 Install an air fitting to the compressed-air filter located under the cabinet skirt that is compatible with the compressed-air supply hose as noted in Paragraph 2.3.2. Plumbing may be hard-piped if preferred.

2.3.2 Refer to the table in Figure 4 to determine the minimum ID of air supply line to the cabinet air inlet. A smaller diameter hose may reduce blasting efficiency. NOTE: An additional air line is required for the optional reverse pulse dust collector.

Minimum compressed air line ID			
Jet Size			
Air Line Length	No. 4	No. 5	No. 6
25 feet	3/4"	3/4"	1"
50 feet	3/4"	3/4"	1"
75 feet	3/4"	1"	1"
100 feet	3/4"	1"	1"

Figure 4

2.3.3 Connect an air line from the air source to the air filter inlet located on the inside of the cabinet skirt.

WARNING

If twist-on type air hose couplings are used, they must be secured by safety pins or wires to prevent accidental disconnection while under pressure. Hose disconnection while under pressure could cause serious injury.

2.4 Ground Cabinet

2.4.1 To prevent static electricity build up, attach an external grounded wire from an earth ground to the grounding lug on the left rear of the cabinet.

2.5 Connect Electrical Service

WARNING

Lockout and tagout the electrical supply before performing any electrical service. Shorting electrical components could result in death, serious injury from electrical shock, or equipment damage. All electrical work, or any work done inside an electrical panel, must be performed by qualified electricians, and comply with applicable codes.

NOTE: 115 volt 1-phase wiring schematics are packaged with this manual, 3-phase schematics are packed in the electrical panel. After wiring is completed, keep the schematic with the manual for future reference and for electrical replacement parts.

Reverse-pulse collectors are usually too far from the cabinet to use flex conduit. Conduit and wiring for RP Collectors, and wiring from the user's disconnect to the cabinet panel must be provided by the user.

2.5.1 115-volt single phase wiring. For 3-phase wiring, see Section 2.5.2.

2.5.1.1 300 cfm and 600 cfm reclaimers do not require any wiring.

2.5.1.2 Incoming power is supplied by a U-Ground plug, and requires only plugging into 115-volt outlet. **SEE FOLLOWING IMPORTANT WARNING**

WARNING

Do not use electrical adaptors that eliminate the ground prong on 115 volt plugs. Doing so can cause electric shock and equipment damage.

2.5.1.3 Observe the subsequent warning and check the rotation of the motor. To check, jog the starter (momentarily turn switch on and off). This will cause the motor to rotate slowly. Look through the slots in the fan housing on top of the motor where rotation of the fan can easily be observed. Proper rotation is indicated by the arrow on the exhaustor housing. The fan should rotate toward the exhaustor outlet.

WARNING

Do not look into the reclaimer exhaustor outlet while the paddle wheel is turning. Injury to the eye or face could occur from objects being ejected from the exhaustor.

2.5.2 Optional Three-Phase Wiring. For 1-phase wiring, see Section 2.5.1.

2.5.2.1 As much wiring as possible has been completed at the factory. The electrician only needs to provide service to the motor starter in the electrical panel mounted on the cabinet, and connect the conduit and wiring from the starter to the motor. Refer to the schematic packed in the panel. NOTE: The user must provide conduit and wiring from the starter to the motor for RP Collectors.

2.6 Dust Bag and Dry Filter Dust Collector. See separate manual for Reverse-Pulse Dust Collector.

2.6.1 Dust Bag

2.6.1.1 Attach the bag to the reclaimer outlet. Install the bag vertically with the zipper facing down. Use worm clamp to secure.

2.6.2 Dry Filter Dust Collector

2.6.2.1 A 600 cfm dry filter can be converted to left or right hand inlet. If it is more convenient to have the inlet on the opposite side, switch the inlet adaptor for the blank cover.

2.6.2.2 Connect the flexible exhaust hose between the reclaimer outlet and dry filter inlet adaptor. It is easier to slip the hose over the adaptors, and create a tighter seal if the first two or three inches of wire are removed from the inside of the hose. Use care not to damage the hose. Secure the hose with worm clamps. NOTE: The hose wire helps dissipate static electricity in the conveying hose, and also helps ground each segment. In order for the hose wire to dissipate static electricity, the wire must touch the metal of each segment.

2.7 Final Assembly

2.7.1 Position the foot pedal on the floor at the front of the cabinet.

2.7.2 A package of 5 cover lenses is supplied with the cabinet. To install a cover lens, remove the adhesive backing and apply the lens to the clean, dry, inner surface of the view window per Section 6.4. When the cover lens becomes pitted or frosted, replace it.

3.0 FIELD INSTALLED ACCESSORIES

3.1 Alox Kit

3.1.1 The optional aluminum oxide kit is available factory installed or may be field installed later. Factory installed Alox kits consist of four rubber curtains with eyelets, curtain hardware, and boron carbide nozzle. Refer to Section 3.2 for curtain installation.

NOTE: Wear plates and lined flex hose are standard on current cabinets. If the cabinet has both items and they are in good condition, reserve the new wear plate and hose for future replacement.

3.2 Curtain Installation

3.2.1 Match curtains to corresponding wall and doors.

3.2.2 Front and rear walls: Position the curtain on the wall to be protected. Using the curtains as templates, mark each mounting point through the grommet holes along the upper edge of the curtain. NOTE: When laying out the attachment points, the upper edge of the rear curtain should be below the

bottom edge of the air duct partition. Remove the curtains, and drill a .187" (3/16") diameter hole at each point marked. Install the curtains using the fasteners provided (machine screw, 11/16" OD flat washer, lock washer and nut) at each grommet. The flat washer is used between the screw head and the rubber curtain grommet on all curtains.

3.2.3 Doors: Using protectors against the curtains and outer doors, clamp the door curtains in place. NOTE: When laying out the attachment points, the upper edges of the door curtains should be even with the outer edges of the door's sound proofing panel. Insert a #10 self-drilling screw with an 11/16" OD flat washer through the grommet holes. Use a screw gun with a 5/16" socket to drill and thread the screws through the door's inner wall at each grommet.

3.3 Manometer

3.3.1 Constant static pressure is necessary for precise separation, as the reclaimer's efficiency is accomplished by a centrifugal balance of particle weight and size. The air balance and static pressure are set by adjusting the outlet damper. The manometer measures static pressure. Use the instruction sheet provided with the manometer, for installation and operation instructions. The optional manometer kit is listed in Section 9.1. Refer to Section 5.7 for operation.

4.0 OPERATION

4.1 Media Loading and Unloading

4.1.1 Media Loading: With the exhauster off, add clean dry media, by pouring it into the reclaimer hopper through the reclaimer door. Do not fill past the cone on the reclaimer. **Do not pour media directly into the cabinet hopper, as overflowing may occur.** Overflowing will result in media carryover to the dust collector and possible blockage in the conveying hose. Refill only after all media has been recovered from the cabinet.

The minimum amount of media to charge the system is as follows:

300 CFM Reclaimer.....10 Lbs. Media
600 CFM Reclaimer.....20 Lbs. Media

4.1.2 Media Unloading: To empty the cabinet and reclaimer of media, allow all media to be recovered from the cabinet, turn off the exhauster and place an empty container under the metering valve. Unscrew the plastic plug from the metering valve, permitting media to flow into the container. If media doesn't flow, it has caked.

Open the fill door and stir media until it starts to flow. Replace the plug when the reclaimer is empty.

4.2 Loading and Unloading Parts

WARNING

Use solid fixturing to hold heavy parts in place. Do not remove lift equipment until the part is adequately supported to prevent movement. Moving heavy, unsupported parts may cause them to shift or topple, and cause severe injury. This is especially important with the use of turntables and turntables with tracks.

4.2.1 Load and unload parts through either door.

4.2.2 Parts must be free of oil, water, grease, or other contaminants that will cause media to clump, or clog filters.

4.2.3 When blasting very small parts, place an appropriately sized screen over the grate to prevent parts from falling into the hopper.

4.2.4 Close door. Be certain door is sealed securely, or door interlock system will prevent blasting.

4.3 Blasting Operation

CAUTION

- **Always close cabinet, reclaimer and dust collector doors before blasting. Keep all doors closed during blasting.**
- **Always wear blast gloves.**
- **Avoid pointing the blast nozzle toward the view window.**
- **Use the blow-off nozzle to blow media off parts before doors are opened, or exhauster is switched off.**
- **After blasting, keep doors closed and exhauster on until the cabinet is clear of all airborne dust.**
- **Stop blasting immediately if dust leaks are detected.**

4.3.1 Slowly open the air valve on the air supply hose to the cabinet. Check for air leaks.

4.3.2 Turn on the lights and exhauster. The on/off switch performs both functions.

4.3.3 Adjust the pilot pressure regulator to the required blast pressure per Section 5.1.

4.3.4 Load parts.

4.3.5 Close door. Be certain door is sealed securely, or door interlock system will prevent blasting.

4.3.6 Insert hands into rubber gloves.

4.3.7 To blast; hold the gun firmly and apply pressure to the foot pedal; blasting will begin immediately.

WARNING

Shut down the cabinet immediately if dust discharges from the collector or bag. Check that filters are correctly seated and not worn or damaged. Prolonged breathing of any dust could result in serious lung disease or death. Short term ingestion of toxic dust such as lead, poses an immediate danger to health. Toxicity and health risk vary with type of media and dust generated by blasting. Identify all material being removed by blasting, and obtain a material safety data sheet for the blast media.

NOTE: When blasting small parts, use a solid back rest for the part. Without this assist, especially with longer blasting operations, the operator will tire easily from resisting blast pressure. Whenever possible avoid holding small parts that will require blasting into the glove.

4.3.8 When blasting very small parts, place an appropriately sized screen over the grate to prevent parts from falling into the hopper. If an object should fall through the grate, stop blasting immediately and retrieve it.

4.4 Stop Blasting

4.4.1 To stop blasting, remove pressure on the foot pedal.

4.4.2 Use the blow-off nozzle to blow media off cleaned parts. Allow the exhauster to clear the cabinet of airborne dust before opening the door.

4.4.3 Unload parts, shut off the air supply valve, drain the air filter, and switch off the lights and exhauster.

4.5 Blasting Technique

4.5.1 Blasting technique is similar to spray painting technique. Smooth continuous strokes are most effective. The distance from the part affects size of blast pattern. Under normal conditions, hold the nozzle approximately 3" to 6" from the surface of the part.

5.0 ADJUSTMENTS

5.1 Blasting Pressure

5.1.1 The pilot regulator located on the top, left side of the cabinet, enables the user to adjust blasting pressure to suit the application. The suitable pressure for most purposes is 80 psi. Lower pressures may be used for delicate work. In all cases, highest production can be achieved only when pressure is carefully monitored.

5.1.2 To adjust, unlock the knob, and turn it clockwise to increase pressure or counter-clockwise to decrease pressure. Pressure will usually drop from closed-line pressure when blasting is started. Once operating pressure is set, lock the knob to maintain the setting.

5.2 Air Jet Adjustment

5.2.1 The air jet should be screwed 4-1/2 to 5 full turns into the gun body. Doing so will leave 3-1/2 to 4 threads exposed past the lock nut. Tighten the lock nut to hold the jet in place. See Section 9.1 or 9.3 for optional orifice adjusting tool.

5.3 Media/Air Mixture, Figure 5

5.3.1 Check the media stream for correct media/air mixture; media flow is smooth and appears as a light mist coming from the nozzle.

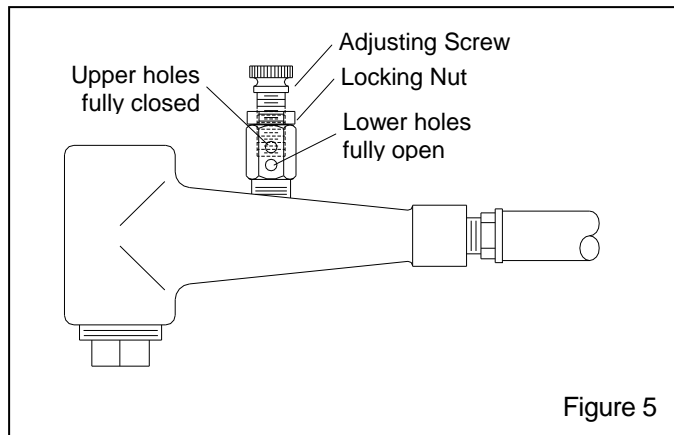

5.3.2 If media does not flow smoothly, loosen the locking nut, and adjust the metering screw until the upper

holes in the metering stem are closed-off, and the lower holes are fully open. See Figure 5. This adjustment is a starting point.

5.3.3 If pulsation occurs in the media hose, either media is damp and caked, or not enough air is entering the media stream. While blasting, loosen the locking nut and slowly turn the adjusting screw out (counterclockwise when viewed from the top) until the media flows smoothly. Tighten the locking nut to maintain the setting.

5.3.4 If media flow is too light, decrease air in the mixture by turning the metering screw in (clockwise when viewed from the top) covering more of the holes so less air enters the media hose. Tighten the locking nut to maintain the setting.

5.4 Static Pressure (dust collector models only)

5.4.1 Correct static pressure varies with size of reclaimers and the size, weight and type of media.

5.4.2 Adjust static pressure by opening (handle horizontal) or closing (handle vertical) the damper. The damper is located on the inlet on dry filters, and on the outlet of reverse pulse dust collectors. If the damper is not opened enough, the reclaimers will not remove fines, resulting in dusty media, poor visibility, and possible media blockage in the conveying hose. If the damper is opened too far, it may cause carryover (usable media carried into the dust collector) and result in excessive media consumption. Open only as far as necessary to obtain a balance of dust removal without media carryover.

5.4.3 A manometer is useful when adjusting or monitoring static pressure. The optional manometer kit is listed under Optional Accessories in Section 9.1. The following are static pressure starting points for given media. Static pressure may need to be lower with finer media, higher with coarser media. Refer to Section

Glass Bead No. 8 to 13	2-1/2 - 3"
Alox. 60 & coarser	4 - 5"
Alox. 80 & finer	2-1/2 - 3"

5.4.4 If the damper has been adjusted and carryover or excessive dust in the media continues to be a problem, the optional adjustable vortex cylinder, which is standard on pull through reclaimers, may help retain media. The vortex cylinder is usually required only when using 200 mesh and finer media, or lightweight media. See Section 5.5, and Accessories in Section 9.1.

5.5 Optional Externally Adjustable Vortex Cylinder (standard on pull-through reclaimers).

5.5.1 The adjusting lever for the vortex cylinder is mounted on the spacer between the reclaimer body and exhauster housing. Start with the lever in the vertical position. Before adjusting the vortex cylinder, adjust the damper on the dust collector to increase or decrease static pressure per Section 5.4. Once the damper has been adjusted, adjust the cylinder as follows.

5.5.2 To Remove More Fines: (Too much dust in media) Raise the cylinder by moving the lever left toward "COARSE", in 1/4" increments at the indicator plate. Do not adjust again until the media has gone through several cycles, to be certain that further adjustment is required.

5.5.3 To Remove less Fines: (Excessive usable media is carried to the dust collector) Lower the vortex cylinder by moving the lever right toward "FINE", in 1/4" increments at the indicator plate. Note: If the cylinder is lowered too far, the reclaimer will again begin to allow usable media to be carried over, and cause abnormally high static pressure.

5.5.4 When using 200 mesh and finer media, the inlet baffle of the reclaimer may need to be removed. Consult the factory before proceeding with this option.

5.6 Door Interlocks, Figure 6

⚠ WARNING

Never attempt to override the interlock system. Doing so could result in injury from unexpected blasting.

5.6.1 The door interlocks disable the blasting control circuit when the doors are open. To enable blasting, the door interlock switches must be engaged when the doors are closed. The interlocks are set at the factory and do not usually require field adjustment unless parts are replaced. When adjustment is required, proceed as follows.

5.6.2 Close cabinet doors.

5.6.3 Loosen the actuator bracket screws and adjusting screw nut. Move the actuator adjusting bracket up or down, and the adjusting screw sideways, to center the adjusting screw on the over-travel stop. Tighten the bracket screws.

5.6.4 Turn the adjusting screw in or out as required to engage the switch without applying excessive pressure on it. Tighten the adjusting screw nuts.

5.6.5 Test the operation with the doors open and then again closed. Point the nozzle away from the door during the tests, and only open the door enough to disengage the interlock switch. The interlocks should stop the blasting when the doors are opened, and permit blasting when the doors are closed. NOTE: Negative pressure inside the cabinet may cause the doors to flex inward. Tests should be performed with the exhauster on.

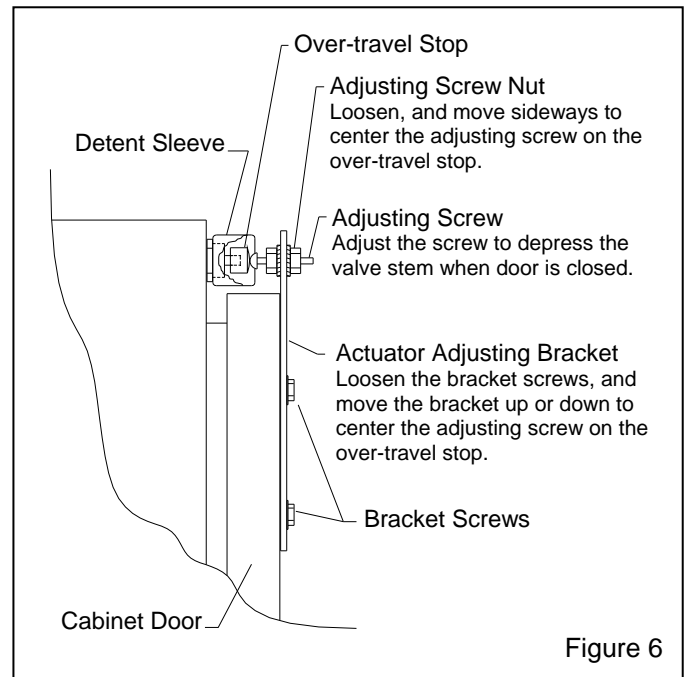

Figure 6

5.7 Optional Manometer, Figure 7

NOTE: The following instructions explain the use of the manometer, Clemco Stock No. 12528, for taking periodic static pressure readings on reclaimers. Permanent fittings should be installed when the manometer installation is permanent. Use silicone sealer or other sealant to seal around the fitting to prevent leaks. To prevent negative pressure air leaks, the fitting should be capable of being capped when the manometer tube is removed.

5.7.1 The illustration in Figure 7 shows the manometer, Stock No. 12528, set-up for taking periodic static pressure readings on pull-through and push-through reclaimers.

5.7.2 Refer to directions packed with the manometer for filling and operation instructions for the manometer.

5.7.3 Connect one end of the 3/16" ID tubing to the tubing adaptor on the manometer, by pushing it over the barbed fitting.

5.7.4 Leaving the needle protector on the needle, insert the needle into the other end of the tubing. The ends of the tubing must fit tight on the manometer and needle; leaks will give inaccurate readings.

5.7.5 Open both manometer valves (elbows) one full turn.

5.7.6 Magnets on the manometer hold it in position on the reclaimer body. The manometer must be vertically plumb so the fluid is level on both sides.

5.7.7 Adjust the slide rule to align the zero with the fluid level.

5.7.8 Needle placement: Refer to Figure 7

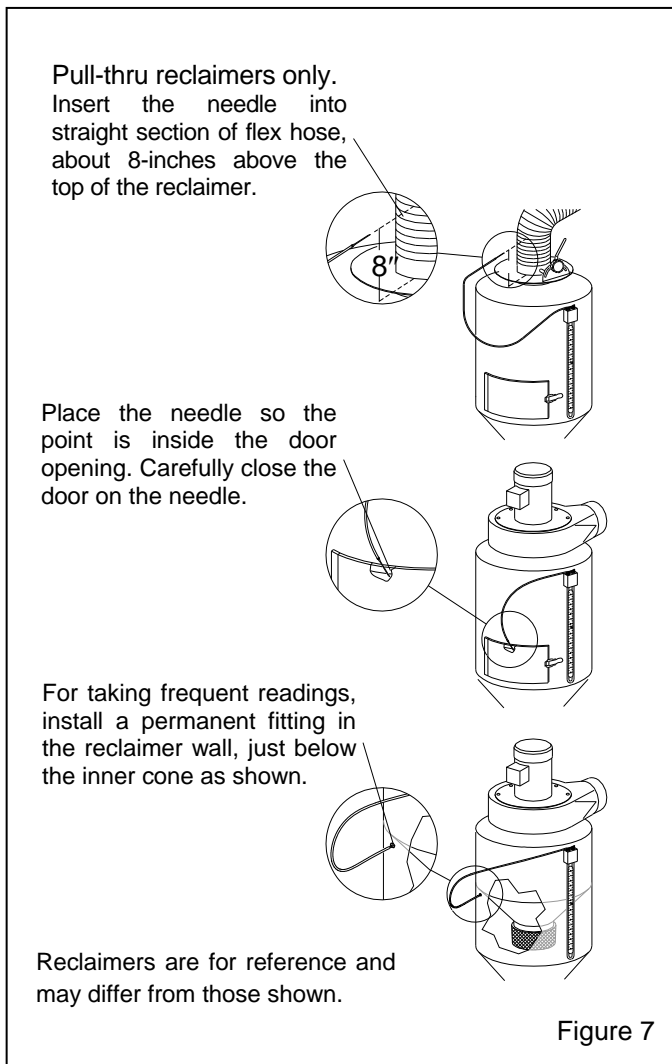

5.7.10 Push-through reclaimer (with exhauster): Open the reclaimer fill door, remove the needle protector and place the needle so the point is inside the door opening. Carefully close the door on the needle. The side of the needle will embed into the rubber, creating an airtight seal. Static pressure readings at the door are generally .5" to 1" lower than those taken above the reclaimer.

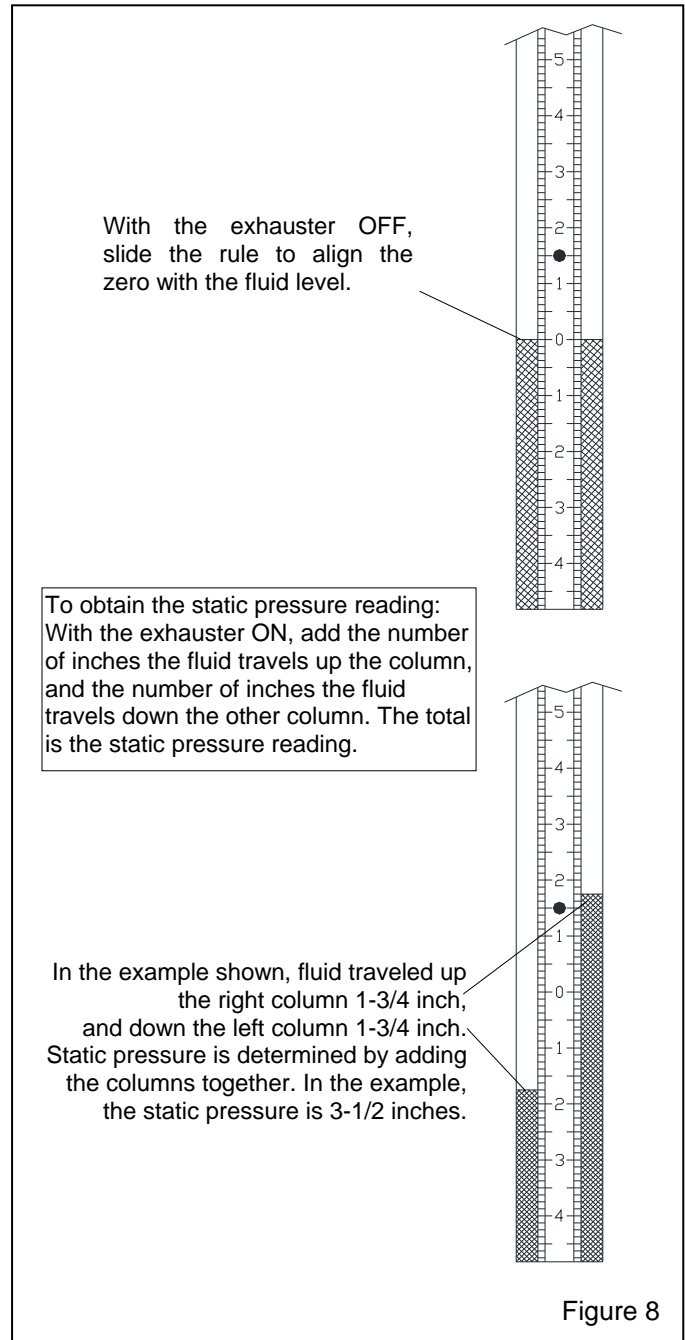

5.7.9 Pull-through system (reclaimer without exhauster): Remove the needle protector, and insert the needle into the flex hose approximately 8" from the top of the reclaimer.

5.7.11 Turn the exhauster ON. The negative (static) pressure will move fluid in the tube. NOTE: Readings must be taken with the enclosure cabinet door open, and with the exhauster running.

5.7.12 To find the static pressure, observe the fluid level in each column above and below zero (level line), and add the readings together. See the example in Figure 8

5.7.13 After the taking the readings, replace the needle protector. Close the manometer valves and store the manometer in the original container in a clean area. Note: If the manometer installation is permanent, the manometer may remain on the reclaimer body after the valves are closed.

6.0 PREVENTIVE MAINTENANCE

WARNING

Failure to wear approved respirators and eye protection when servicing dust-laden areas of the cabinet and dust collector, and when emptying the dust bag or collector could result in serious eye irritation and lung disease or death. Toxicity and health risk vary with type of media and dust generated by blasting. The respirator must be approved for the type of dust generated. Identify all material being removed by blasting, and obtain a material safety data sheet for the blast media.

NOTE: To avoid unscheduled downtime, establish a weekly inspection schedule. Inspect all parts subjected to media contact, including; the gun, nozzle, media hose, flex hose, and wear plate, plus all items covered in this section.

6.1. BNP Gun Assembly

6.1.1 Inspect the BNP gun for wear. Inspection and replacement of the air jet cover before it wears through will prolong the life of the jet.

6.2 Dust Bag

6.2.1 The bag collects dust on its inner surface. A high dust level in the cabinet indicates a dirty bag. Empty as frequently as necessary to maintain visibility in the cabinet, and before the weight of dust prevents full inflation of the bag. A zipper opening is located in the bottom of the bag for emptying. NOTE: Poor visibility and frequent emptying of the bag could indicate the need to upgrade to a dry filter dust collector.

6.3 Dry Filter Dust Collector

6.3.1 The dry filter uses tubular filters which collect dust on their inner surfaces. A shaker arm accessible from the outside of the collector is used to shake dust from the filters. Every two hours, turn off the exhauster and shake the filters vigorously.

CAUTION

Do not shake the filters when the exhauster is on, doing so will accelerate wear on the filters around the shaker assembly, but not shake the dust loose.

6.3.2 Empty the dust collector drawer regularly. Begin by checking the drawer daily and adjust frequency based on usage and breakdown rate of media. Dump the contents into a suitable disposal container.

CAUTION

Do not open the dust drawer door while the exhauster is on. The drawer chamber is under positive pressure when the exhauster is on. Opening the dust door while the exhauster is operating or the paddle wheel rotating, will allow dust to escape.

NOTE: Blast media is usually non-toxic, however, some materials removed by the process may be toxic. Obtain MSDS sheets for the media and identify all material removed by the blast process. Check with proper authorities for disposal restrictions.

6.4 View Window Cover Lens

6.4.1 Rapid frosting of the view window can be avoided by directing ricocheting media away from the window, and by installing a cover lens on the inside surface of the window. Using cover lenses prolongs the life of the view window.

6.4.2 The best way to install a cover lens is to remove the window from the cabinet. If, for some reason, it is not helpful to remove the window, the lens may be applied with it in place.

6.4.3 To install a cover lens, remove the adhesive backing and apply the lens to the clean, dry, inner surface of the view window. When the cover lens becomes pitted or frosted, replace it.

6.5 Reclaimer Debris Screen

6.5.1 The screen is accessible through the reclaimer door. With the exhauster off, remove the screen and empty it daily or when loading media. Empty the screen more often if part blasted causes excessive debris. Do not operate the machine without the screen in place.

6.6 Air Filter

6.6.1 The cabinet is equipped with a manual drain air filter. Drain the filter at least once a day, and more often if water is present. Moist air inhibits the flow of media. If damp air continues to cause problems, a dryer or after cooler may be required in the air supply line.

6.7 Media Hose

6.7.1 To avoid unscheduled down-time, periodically inspect the media hose for thin spots, by pinching it every 6 to 12 inches.

7.0 SERVICE MAINTENANCE

WARNING

Failure to wear approved respirators and eye protection when servicing dust-laden areas of the cabinet and dust collector, and when emptying the dust bag or collector could result in serious eye irritation and lung disease or death. Toxicity and health risk vary with type of media and dust generated by blasting. Identify all material being removed by blasting, and obtain a material safety data sheet for the blast media.

7.1 Gloves

7.1.1 Special static-dissipating gloves are provided for operator comfort. It will be necessary to change gloves periodically as they wear. The first sign of deterioration may be excessive static shocks.

7.1.2 Gloves are held in place by metal bands on the inside of the cabinet. To replace, loosen the bands with a screwdriver, replace the gloves, and tighten the bands.

7.2 Nozzle

7.2.1 Replace the nozzle when its diameter has increased by 1/16", or when suction diminishes noticeably. To change the nozzle, unscrew the holding nut from the gun end, and pull the nozzle from the gun. Inspect the nozzle O-ring and replace if worn or damaged. Insert a new nozzle, placing the tapered end toward the jet. Screw the holding nut onto the gun.

7.3 View Window Replacement

WARNING

Do not use plate glass for replacement view windows. Plate glass shatters on impact and could cause severe injury. Use only genuine replacement parts.

7.3.1 Lift the light shield up and remove the two window frame nuts located on the upper edge of the window frame, and swing the window frame open. Note: If the frame is to remain open, for cleaning or other reasons, remove it per Section 7.5.

7.3.2 Remove the old window.

7.3.3 Inspect the window frame gaskets, both on the window frame and on the cabinet. If either gasket is damaged, replace it per section 7.4.

7.3.4 Install optional view window cover lens per Section 6.4.

7.3.5 Set the new window (cover lens down) squarely over the window opening, ensuring that all edges of the window are centered and overlapping the window gasket, and that the window is resting on the lower locators.

7.3.6 Swing the window frame into place and tighten the frame nuts.

7.4 Window Gasket Replacement, Figure 9

7.4.1 Replace the window frame gasket and cabinet window opening gasket at the first sign of media leakage around the view window, or if gaskets appear damaged. Check the gaskets when changing the view window.

7.4.2 Remove the window and window frame per Section 7.5.

7.4.3 Remove all the old gasket material and clean the surfaces of the cabinet and window frame.

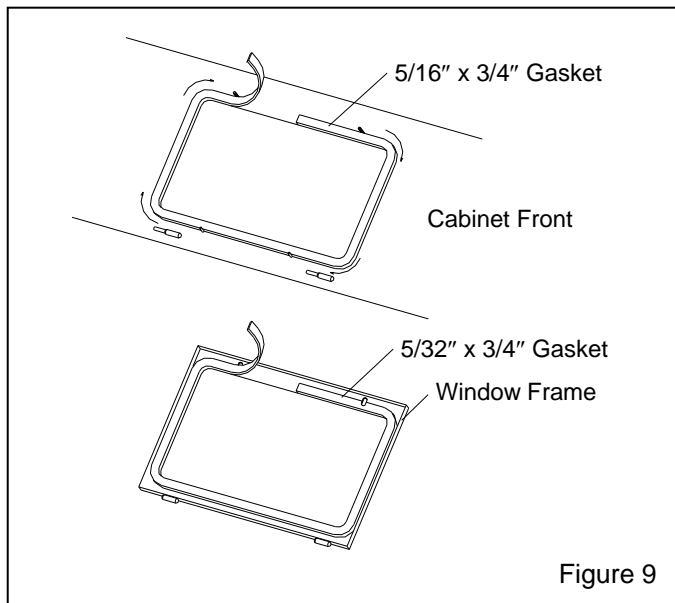

7.4.4 Peel a short section of adhesive backing from the 5/16" thick strip gasket, and adhere the gasket to the center of the top edge of the window opening as shown in Figure 9. Peel additional backing as needed, and work the strip around the radius of each corner, pressing it tightly to bond. Trim the gasket to fit and compress the ends to seal.

7.4.5 Using 5/32" thick strip gasket, repeat the process on the window frame.

7.4.6 Trim around the window frame bolt slots, as needed.

7.5 Window Frame Removal, Figure 10

7.5.1 Remove the two window frame nuts located on the upper edge of the window frame, and swing the window frame open.

7.5.2 Remove the window to prevent breakage.

7.5.3 Pivot the window frame up or down until tension is off the frame hinges.

7.5.4 To remove, slide the frame to the right. The hinges separate as shown in Figure 10.

7.5.5 Replace the frame in reverse order. Align the top bolt holes with the bolts; slide the frame as necessary.

7.5.6 Set the window squarely over the window opening, ensuring that all edges of the window are centered and overlapping the window gasket, and resting on the lower locators.

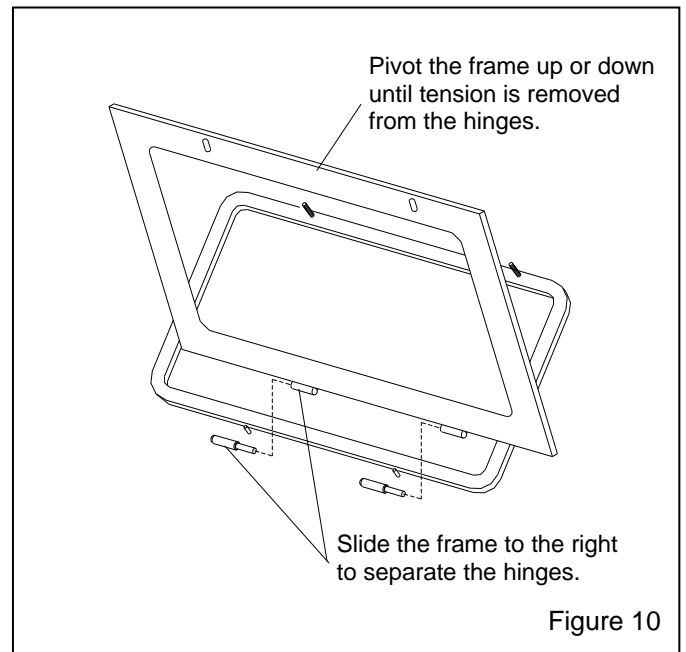

7.5.7 Swing the window frame into place and tighten the frame nuts.

7.6 Dry Filter Tube Replacement, Figure 11

CAUTION

- Do not bend spring ends tight enough to cause ends to kink.
- Do not use a sharp instrument to force spring rings into the opening. This could damage the filter and seriously impair the function of the dust collector.
- Install one filter at a time. Check the seating of the top and bottom spring rings, and that tube is not twisted, before proceeding to the next.

7.6.1 Replace damaged filters immediately. Remove the old filters by pulling the spring rings off the bottom and top tube plates. Working from the back to the front, install one filter at a time. To install new filters, form the end of the spring ringed tubular filter into a shallow "c" shape, push the filter far enough into the hole of the top plate to allow one spring ring to snap into place above the tube plate and the other to snap into place below it. See the illustration in Figure 11.

7.6.2 The tubular filter is held firmly by spring rings above and below the perimeter of the hole in the top and bottom tube plate. The filters fit tight to prevent dust leakage. Force may be required by the installer. Check for proper seating at both ends, and remove any twist in the tube before proceeding to the next filter.

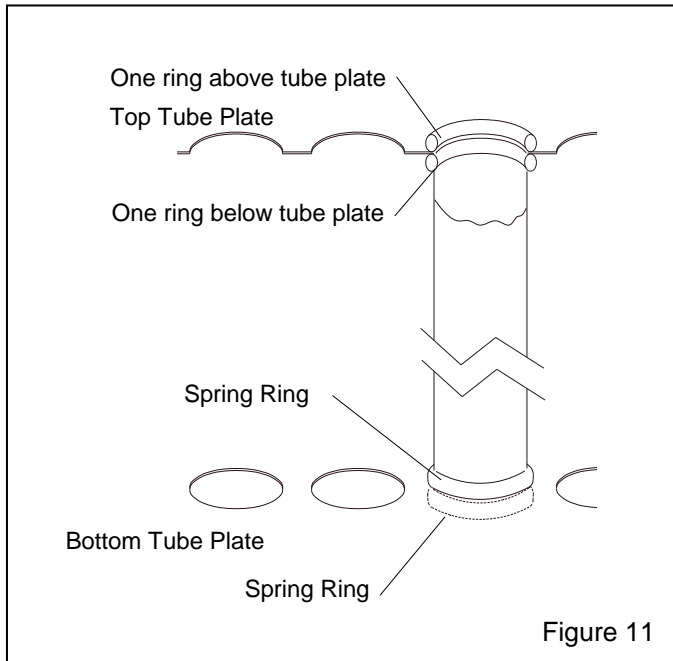

Figure 11

7.7 Dust Bag

7.7.1 Replace the bag at first sign of dust leak, or as necessary to maintain visibility in the cabinet. If visibility is poor, periodic washing may restore the porosity of the cloth and increase ventilation through the cabinet.

7.8 Reclaimer Wear Plate Replacement

7.8.1 Remove the reclaimer inlet adaptor and old wear plate. The wear plate is held in place by screws attached from the outside of the reclaimer.

7.8.2 Angle the new wear plate into the reclaimer inlet until it is in position with the straight end at the reclaimer inlet. Using a board or similar object as leverage, pry the wear plate against the inner wall of the reclaimer and install sheet metal screws to hold in place. Caulk any gaps or voids around the wear plate to prevent rapid wear in those areas.

7.9 RP Dust Collector

Optional reverse-pulse dust collectors are covered by a separate manual.

8.0 TROUBLESHOOTING

⚠ WARNING

To avoid serious injury, observe the following when troubleshooting.

- Turn off the air, and lock out and tag out the air supply.
- If checking the controls requires air, always enlist the aid of another person to:
 - Hold the blast gun securely.
 - Operate the foot pedal.
- Never bypass the foot pedal or wedge it in the operating position.
- Never override the door interlock system.

8.1 Poor Visibility

8.1.1 Dirty filter bag(s), tube filters or filter cartridge. Shake tube filters, and empty dust drawer regularly. Ref. RP Dust Collector Manual for pulse pressure and sequence.

8.1.2 Motor rotating backwards. The motor should rotate as indicated by the arrow on the housing. If it does not rotate in the proper direction, **lockout and tagout power** and switch the motor leads as shown on the motor plate. See Section 2.5.

8.1.3 Using friable media that rapidly breaks down, or using media that is too fine or worn out.

8.1.4 Dust collector damper closed too far restricting air movement in cabinet. Adjust static pressure per Section 5.4.

8.1.5 Blocked air inlet duct. Blockage in the air intake ducts restricts incoming air and reduces air movement in the cabinet.

8.1.6 Hole worn in flex hose between cabinet hopper and reclaimer inlet (if RP collector is used also check hose between the reclaimer outlet and dust collector inlet). Replace hose and route it with as few bends as possible to prevent wear.

8.1.7 Reclaimer door open.

8.1.8 Obstruction in flex hose between the cabinet hopper and reclaimer inlet.

8.1.9 Paddle wheel worn. Check wheel for wear.

8.2 Abnormally High Media Consumption

8.2.1 Door on reclaimer open, or improper fit or worn door gasket. Air entering the reclaimer at this point will cause media to be carried into the dust collector. DO NOT operate unless all doors are closed.

8.2.2 Dust collector damper open too far. Adjust static pressure per Section 5.4.

8.2.3 Media may be too fine or worn-out.

8.2.4 Using friable media that rapidly breaks down.

8.2.5 Nozzle pressure too high for the media, causing media to break down.

8.2.6 Hole worn in reclaimer, or leak in reclaimer seams. Check entire reclaimer for negative-pressure leaks.

8.2.7 If using very fine media (200 mesh and finer), the inlet baffle of the reclaimer may need to be removed. Consult the factory before proceeding with this option.

8.2.8 Optional externally adjustable vortex cylinder out of adjustment. See Section 5.5.

8.3 Reduction In Blast Cleaning Rate

8.3.1 Low media level reducing media flow. Check and fill if low.

8.3.2 Incorrect metering valve adjustment. Adjust per Section 5.3.

8.3.3 Reduced air pressure. This may be caused by a malfunctioning regulator, a dirty filter element in the air filter, partially closed air valve, leaking air line, or other air tools in use.

8.3.4 Blockage in media line or gun. Blockage may occur as a result of a missing debris screen, or incorrect metering valve adjustment permitting heavy media flow. See Section 5.3.

8.3.5 Worn gun parts such as nozzle or air jet. Inspect and replace all worn parts.

8.3.6 Worn media hose. Check hose for leaks and soft spots. Replace worn or damaged hose.

8.3.7 Air jet in gun out of adjustment. Check adjustment per Section 5.2.

8.3.8 Moist media. Frequent bridges or blockage in the area of the metering valve can be caused by moisture. See Section 8.5.

8.4 Plugged Nozzle

8.4.1 A damaged or missing reclaimer screen will allow large particles to pass and block the nozzle. Replace or re-install as necessary.

8.4.2 Media mixture too rich. Adjust media/air mixture per Section 5.3.

8.5 Media Bridging

8.5.1 Frequent bridging or blockage in the media metering valve can be caused by damp media. Media becomes damp by blasting parts that are slightly oily, from moisture in the compressed air line, or from absorption.

8.5.2 To avoid contaminating media from the workpiece, all parts put into the cabinet should be clean and dry. If parts are oily or greasy, degrease and dry them prior to blasting.

8.5.3 Moist compressed air may be due to a faulty compressor that overheats, or pumps oil or moisture into the air line, too long an air line permitting moisture to condense on the inside, and from high humidity. Drain the air filter and receiver tank regularly. If the problem persists, it may be necessary to change media more often, or install an aftercooler or air dryer.

8.5.4 Absorption. Some media tends to absorb moisture from the air, especially fine-mesh media in high humidity areas. Empty the media and store it in an airtight container when cabinet is not in use.

8.5.5 A vibrator attached to the reclaimer cone or media metering valve may help prevent bridging of fine-mesh media.

8.6 Neither Media Nor Air Comes Out The Nozzle When The Foot Pedal Is Pressed.

8.6.1 Door interlocks not engaging. Check adjustment per Section 5.6.

8.6.2 Blocked or leaking control lines. Check all urethane tubing for blockage or leaks.

8.6.3 Foot pedal valve malfunction. Check foot pedal alignment, and inlet and outlet lines for pressure.

8.6.4 Check that lines are not reversed on the foot pedal or pilot regulator. Refer to the schematic in Figure 17.

8.6.5 Pressure regulator may be turned down or off. Check pressure on pilot regulator.

8.6.6 Make sure that the air compressor is on and air supply valves are open.

8.6.7 Check the nozzle to see if it is plugged. See Section 8.4.

8.7 Blasting Does Not Stop When The Foot Pedal Is Released

8.7.1 Make sure that the 3-way valve in the foot pedal exhausts air when the pedal is released. If it does not, check the line for blockage, and check the switch for defect.

8.8 Blockage In Media Hose

8.8.1 Media obstructions. Usually caused when the media mixture is too rich. Adjust media/air mixture per Section 5.3.

8.8.2 Wet or damp media. See Section 8.5.

8.9 Media Surge

8.9.1 Heavy media flow. Adjust per Section 5.3.

8.10 Poor Suction In Media Hose

8.10.1 Inadequate air supply. Check the tables in Figures 3 and 4.

8.10.2 Air jet needs adjustment. Check adjustment per Section 5.2.

8.10.3 Nozzle is worn. Replace if worn 1/16" or more.

8.10.4 Blockage in media hose or nozzle. See Section 8.4 and 8.8.

8.10.5 Air jet and nozzle combination may be wrong. Refer to the table in Figure 3.

8.10.6 Air jet sleeve extends past end of air jet. Cut the sleeve to align with the air jet.

8.11 Blow-Back Through Media Hose

8.11.1 Blockage in nozzle. Remove the nozzle and check blockage.

8.11.2 Air jet may be too large for nozzle. See table in Figure 3.

8.12 Static Shocks

8.12.1 Cabinet and/or operator not grounded. Abrasive blasting generates static electricity. The cabinet must be earth-grounded to prevent static buildup. See Section 2.2.1 and 2.4. If shocks persist, the operator may be building up static. Attach a small ground wire (such as a wrist strap), from the operator to the cabinet.

8.12.2 Avoid holding parts off the grate. Static will build-up in the part if not dissipated through the metal cabinet.

8.13 Dust Leaking From Dry Filter Dust Collector

Refer to RP Dust Collector Manual for service of reverse-pulse dust collectors.

8.13.1 Check for damaged or loose filters.

8.13.2 Check for a faulty seal on the dust drawer.

8.13.3 Check that upper and lower tube sheets are sealed on both sides, front, and rear.

9.0 ACCESSORIES AND REPLACEMENT PARTS

9.1 Optional Accessories

Description	Stock No.
20" Turntable, without bearing, 25 lb. capacity	12412
20" Turntable, with bearing, 500 lb. capacity	12411
Aluminum oxide kit: Includes light lined flex hose, reclaimer wear plate, #5 boron carbide nozzle, black rubber curtains with eyelets and curtain hardware.	
for 55 w/ 300 reclaimer	12953
for 55 w/ 600 reclaimer	14129
Rubber curtains, black	
Curtain set	23530
Back curtain	14318
Front curtain	14319
Door curtain, 2 required	14320
Rubber curtains, white	
curtain set	23540
Wear plate kit, field installation	
for 300 cfm reclaimer	14060
for 600 cfm reclaimer	13011
Flex hose, heavy lined, for use with steel and heavy usage with aluminum oxide. Available in 15 ft. lengths only.	
4" ID	12473
5" ID	12465
Tungsten carbide nozzle	
No. 5	13118
No. 7	12882
No. 8	11942
Boron carbide nozzle	
No. 5	11935
No. 6	11936
No. 7	11937
No. 8	12894
Wide-spray nozzle	
Tungsten carbide	
No. 6	11947
Boron carbide	
No. 6	11934
No. 8	11944
NOTE: Wide-spray nozzles require the following accessories:	
Nozzle nut, wide-spray	11916
Retaining ring, wide-spray	12038
Nozzle guard, wide-spray	12295

Vortex cylinder assembly, externally adjustable for exhauster mounted reclaimers. For use with fine-mesh or lightweight media.

for 300 cfm reclaimer	19059
for 600 cfm reclaimer	19062

Time delay door locks	24163
Lock pins (pkg of 25) for twist-on hose couplings ..	11203
Adjusting tool, air jet (orifice)	19041
Manometer kit	12528
Tumble basket, 2 gallon	12227

9.2 Cabinet Replacement Parts, Figure 12

Item	Description	Stock No.
1.	Gasket, door, adhesive backed, 8 ft. per door, specify feet required	00187
2.	Light shield assembly 1-Phase with switch	11601
	3-Phase without switch	22353
3.	Window glass, 12.5" x 19.5"	12212
4.	Gasket, 5/16" x 3/4", applied to cabinet per foot, 6 feet required	00189
5.	Gasket, 5/32" x 3/4", applied to window frame per foot, 6 feet required	00192
6.	Cover lens, pkg. of 5	06190
7.	Door assembly, left	20068
8.	Door assembly, right	20069
9.	Grate for 55	11813
10.	Latch kit, door	20064
11.	Glove set	11215
12.	Glove, left hand only	12710
13.	Glove, right hand only	12711
14.	Clamp, glove	11576

15.	Hose, light lined flex, specify feet required. 4" ID for 300 cfm, 7 ft. required	12466
	5" ID for 600 cfm, 7 ft. required	12467
16.	Clamp, flex hose for 4" hose	11577
	for 5" hose	11578
17.	Grommet, media/air hose	11798
18.	Adaptor pipe universal, flex hose 4" for 300 cfm	23295
	5" for 600 cfm	23296
19.	Gasket, flex hose adaptor pipe 4" for 300 cfm	23258
	5" for 600 cfm	23259
20.	Actuator, door interlock	19152
21.	Over-travel stop, door interlock	20004
22.	Detent sleeve, door interlock	15042
23.	Air valve, 3 way, door interlock	12202
24.	Regulator, 1/8" NPT pilot	12715
25.	Gauge, pressure 1/8" NPT cbm	01908
26.	Foot pedal assembly, less tubing	20483
27.	Nut, plastic, window frame, 2 required	23035

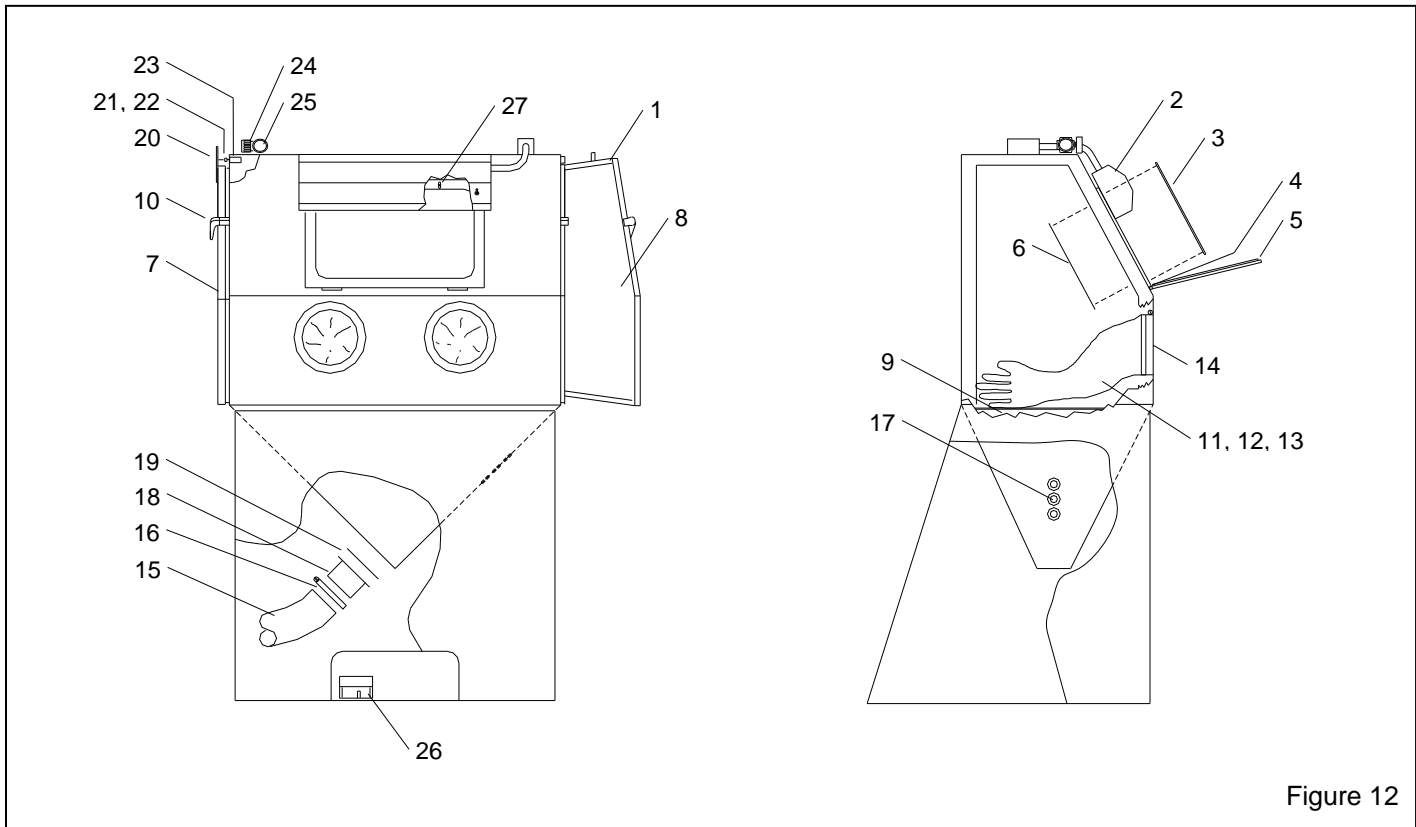

Figure 12

9.3 BNP Gun and Feed Assembly, Figure 13

Item	Description	Stock No.
(-)	BNP Gun assemblies less nozzle, includes items 1 (brass) through 7	
	No. 4 Gun	12301
	No. 5 Gun	12302
	No. 6 Gun	12303
	No. 7 Gun	12304
	No. 8 Gun	12305
1.	Nut, nozzle holding	
	Standard, knurled brass	11914
	Urethane covered	11574
2.	O-Ring	08975
3.	Gun body	11802
4.	Lock nut, air jet	11913
5.	Rubber sleeve	12097
6.	Air jet assembly w/ Item 5	
	No. 4	12342
	No. 5	12343
	No. 6	12344
	No. 7	12345
	No. 8	12346
7.	Fitting, hose, 3/8" NPT x 1/2" barb	06369
8.	Hose end, 1/2" barb x 1/2" fem. swivel	15002

9.	Nozzle, ceramic	
	No. 5	11930
	No. 6	11931
	No. 7	11932
	Nozzle, boron carbide	
	No. 5	11935
	No. 6	11936
	No. 7	11937
	No. 8	12894
	Nozzle, tungsten carbide	
	No. 5	13118
	No. 7	12882
	No. 8	11942
10.	Hose, 1/2" air, specify ft. required	12472
11.	Hose, media, clear urethane, specify ft. required	12476
12.	Wide-spray nozzle	
	Tungsten carbide, No. 6	11947
	Boron carbide	
	No. 6	11934
	No. 8	11944
13.	Wide-spray nozzle nut	
	Knurled brass	11916
	Urethane covered	12906
14.	Wide-spray retaining ring	12038
15.	Wide-spray nozzle guard	12295
16.	Orifice (air jet) adjusting tool	19041

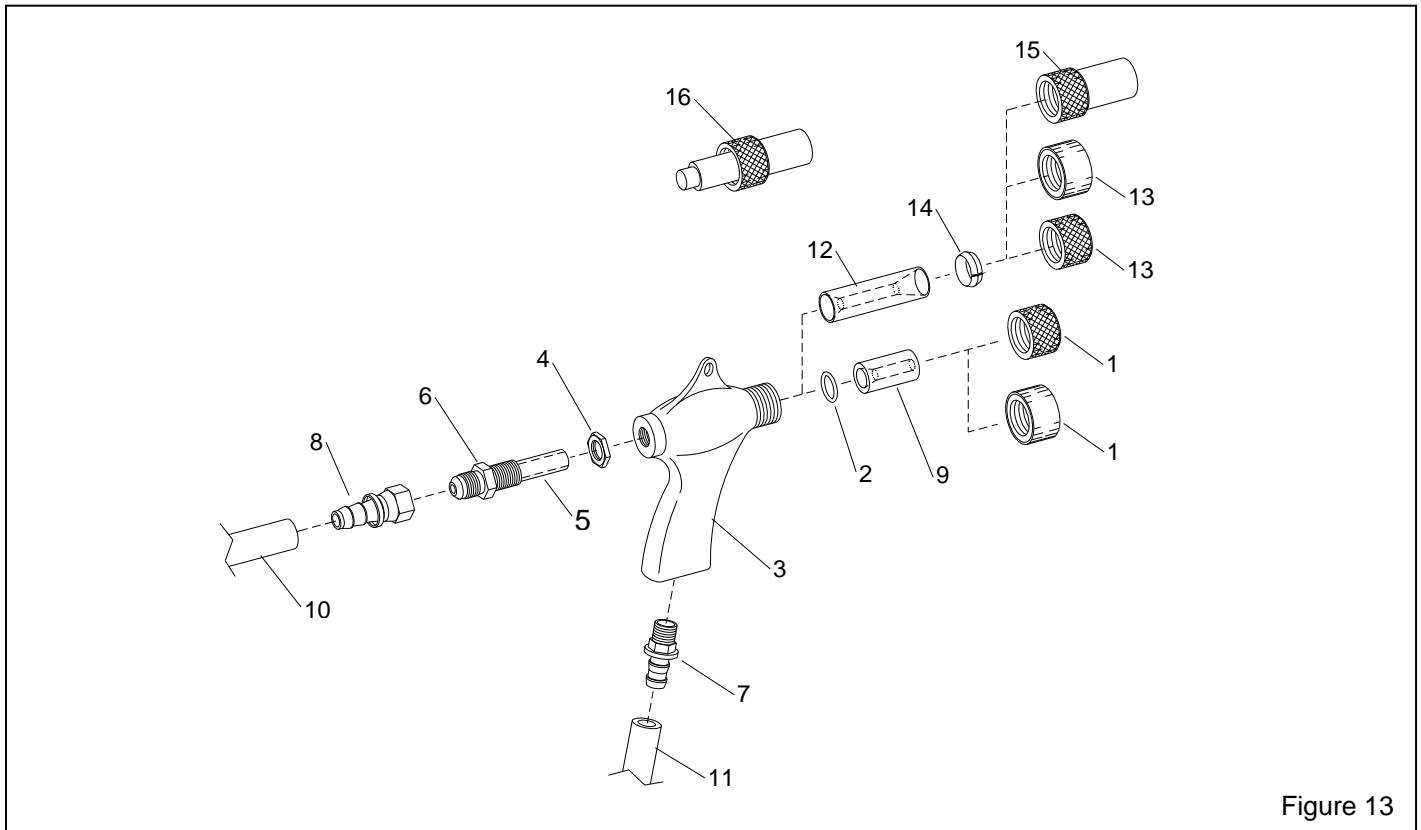

Figure 13

9.4 Foot Pedal Assembly, Figure 14

Item	Description	Stock No.
(-)	Foot pedal assembly, less tubing	20483
1.	Top, foot pedal	20017
2.	Base, foot pedal	19991
3.	Valve, 10-32, 3 way n/c	20026
4.	Drive pin, grooved	20109
5.	Screw, sh 1/4 NF x 3/4"	03086
6.	Screw, 10-32 x 1/2" fh	19571
7.	Adaptor, 10-32 thrd. x 1/8 barb	11731
8.	Spring, 1-1/4" x 3-1/2"	20121
9.	Screw, 8-32 x 3/8" thread cutting	11389
10.	Bumper, rubber (feet)	21522

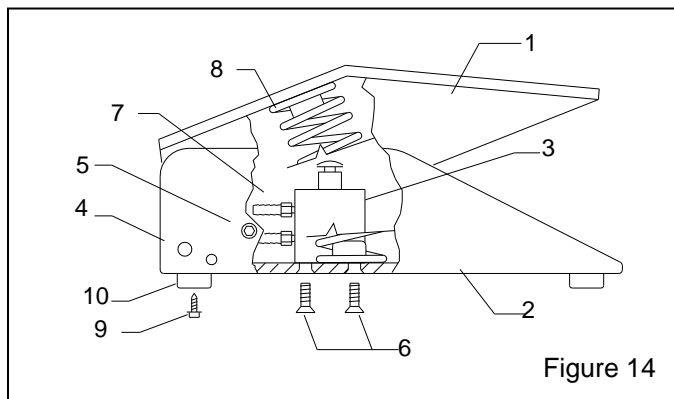

Figure 14

9.5 Metering valve assembly, Figure 15

Item	Description	Stock No.
(-)	Metering valve assembly	12417
(-)	Metering stem assembly (items 1, 2, & 3)	23889
1.	Stem, metering adjusting	23097
2.	Screw, adjusting	23098
3.	Nut, adjusting stem lock	23099
4.	Body, metering valve	11532
5.	Fitting, hose, 3/8" NPT x 1/2" barb	06369
6.	Plug, metering valve	12011

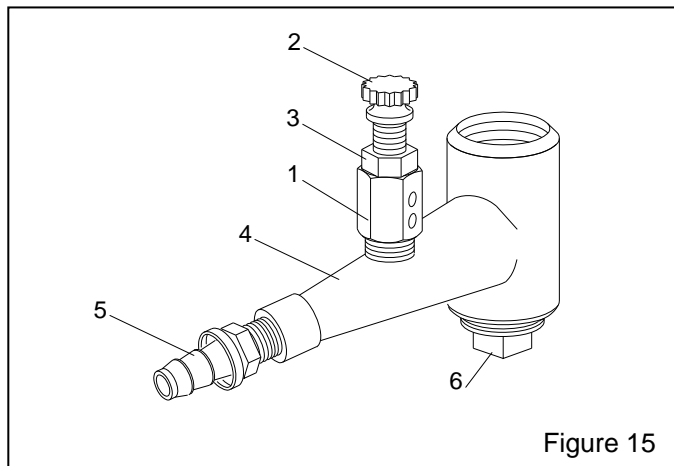

Figure 15

9.6 Light Shield Assembly, Figure 16

Item	Description	Stock No.
(-)	Light shield assembly with switch, 1-Ph.....	11601
(-)	Light shield assembly w/o switch, 3-Ph	22353
1.	Ballast	11553
2.	Lamp holder	11843
3.	Starter holder	12163
4.	Starter	12156
5.	Lamp, 15 watt	11872
6.	Connector, poly straight	02929
7.	Base plate, light shield	11561
8.	Trim edge, 2 ft. required	18460
9.	Switch, on-off	12127

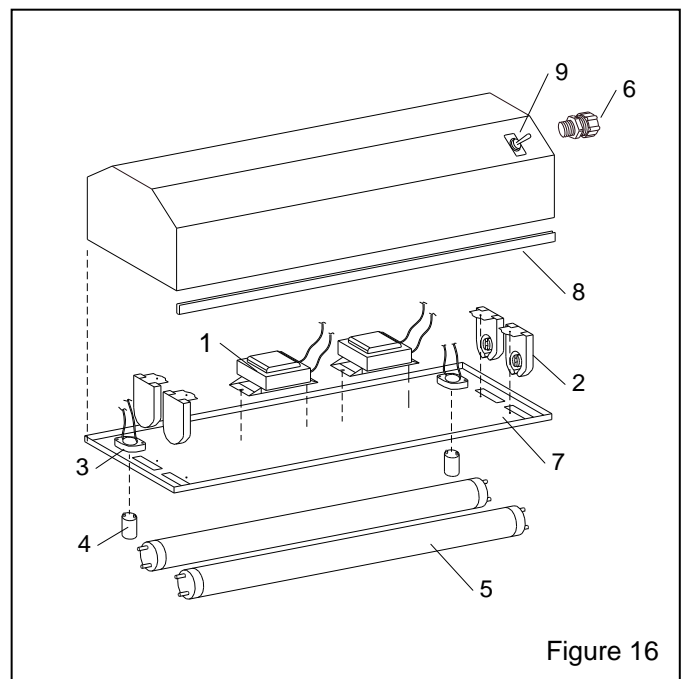

Figure 16

9.8 Reclaimer, Figure 18

Item	Description	Stock No.
(-)	Reclaimer assembly, 300 cfm, complete, w/ exhauster	12402
	less exhauster assembly	12403
	pull-through type, with adj. vortex	21303
(-)	Reclaimer assembly, 600 cfm, complete, w/ exhauster	12400
	less exhauster assembly	12401
	pull-through type, with adj. vortex	21304
1.	Motor, exhauster	
	300 cfm, 1/2 HP, 115/230, 1-PH	12308
	600 cfm, 1 HP, 115/230, 1-PH	12314
2.	Plate, motor mount	
	300 cfm	12003
	600 cfm	12004
3.	Housing, exhauster	
	300 cfm	12273
	600 cfm	12272
4.	Gasket, 5/16" x 1" adhesive backed, 4 ft. required for each location	00187
5.	Paddle wheel	
	300 cfm	12333
	600 cfm	12334

6.	Inlet pipe adaptor	
	300 cfm, 4"	12365
	600 cfm, 5"	12361
7.	Gasket, inlet adaptor	
	300 cfm	11746
	600 cfm	11779
8.	Wear plate	
	300 cfm	14060
	600 cfm	13011
9.	Clamp, hose	
	4-1/2", for 300 cfm	11577
	5-1/2", for 600 cfm	11578
10.	Screen assembly	21265
11.	Gasket, door	11745
12.	Hose, light lined flex, specify length	
	4" ID for 300 cfm	12466
	5" ID for 600 cfm	12467
13.	Spring latch assembly	12263
14.	Vortex cylinder assembly, adjustable, for exhauster mounted reclaimer (optional)	
	300 cfm	19059
	600 cfm	19062
15.	Vortex cylinder assembly, adjustable, standard with pull-through reclaimer	
	300 cfm	19077
	600 cfm	19080

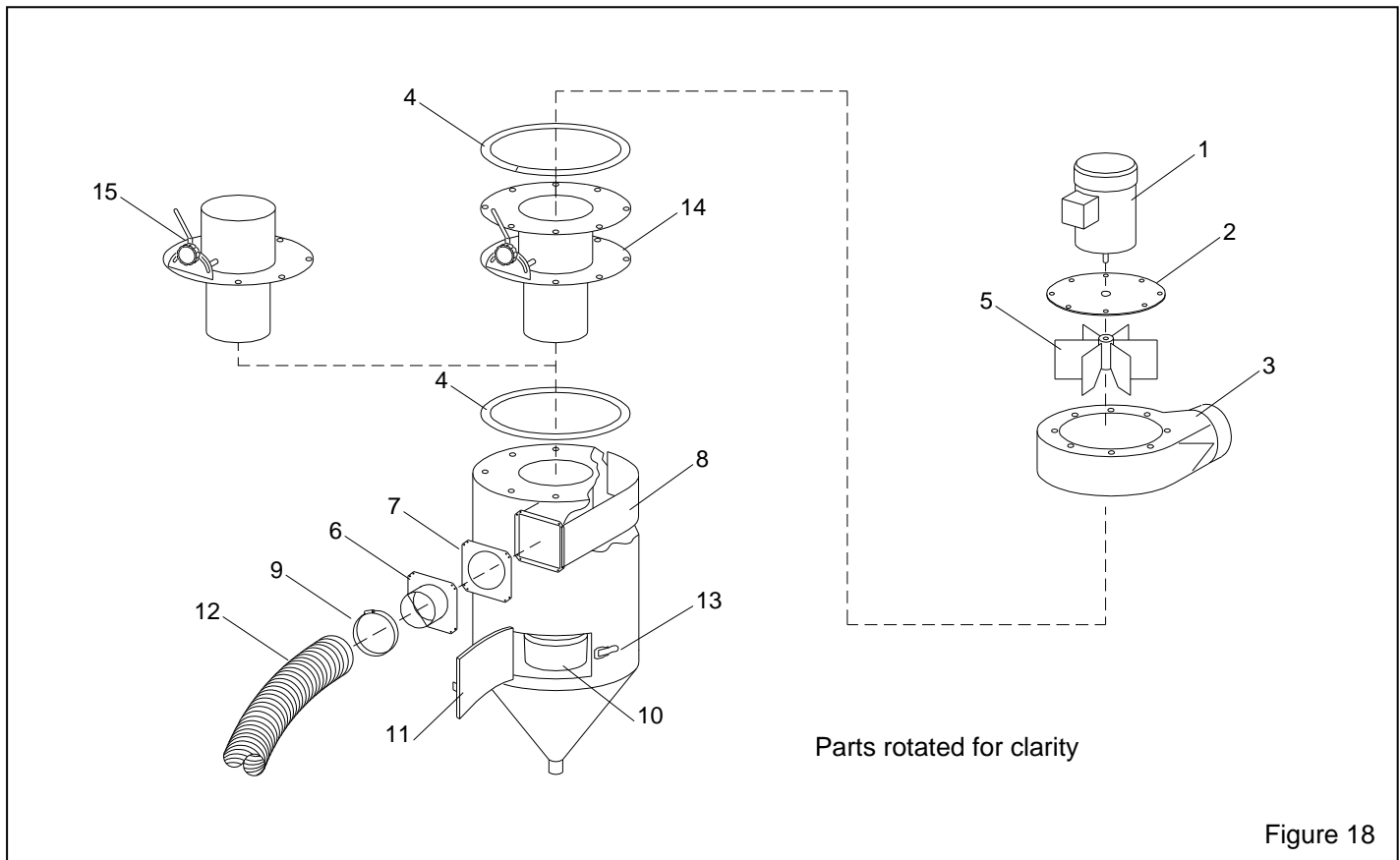

Figure 18

9.9 Dry Filter Dust Collector and Dust Bags, Figure 19

Item	Description	Stock No.
(-)	Dry filter, complete	
	300 cfm	12699
	600 cfm	12700
1.	Hose, flex, specify length, 5 feet is standard.	
	5" for 300 cfm	12449
	6" for 600 cfm	12452
2.	Inlet adaptor w/ damper	
	5" for 300 cfm	21232
	6" for 600 cfm	14272
3.	Gasket, inlet adaptor	
	for 300 cfm	21233
	for 600 cfm	11762
4.	Gasket, dust drawer	11771
5.	Clamp, hose	
	5-1/2", for 300	11578
	6-1/2", for 600	00750
6.	Spring latch assembly	12263
7.	Drawer, dust	
	for 300 cfm	14274
	for 600 cfm	14275
8.	Plate, inlet cover	
	for 600 cfm	14277
9.	Tubular filter, each	11503
	300 cfm requires 15	
	600 cfm requires 25	
10.	Shaker, tube filter	
	300 cfm	12413
	600 cfm	12414
11.	Handle, shaker	12899
12.	Dust bag	
	300 cfm	11501
	600 cfm	11502

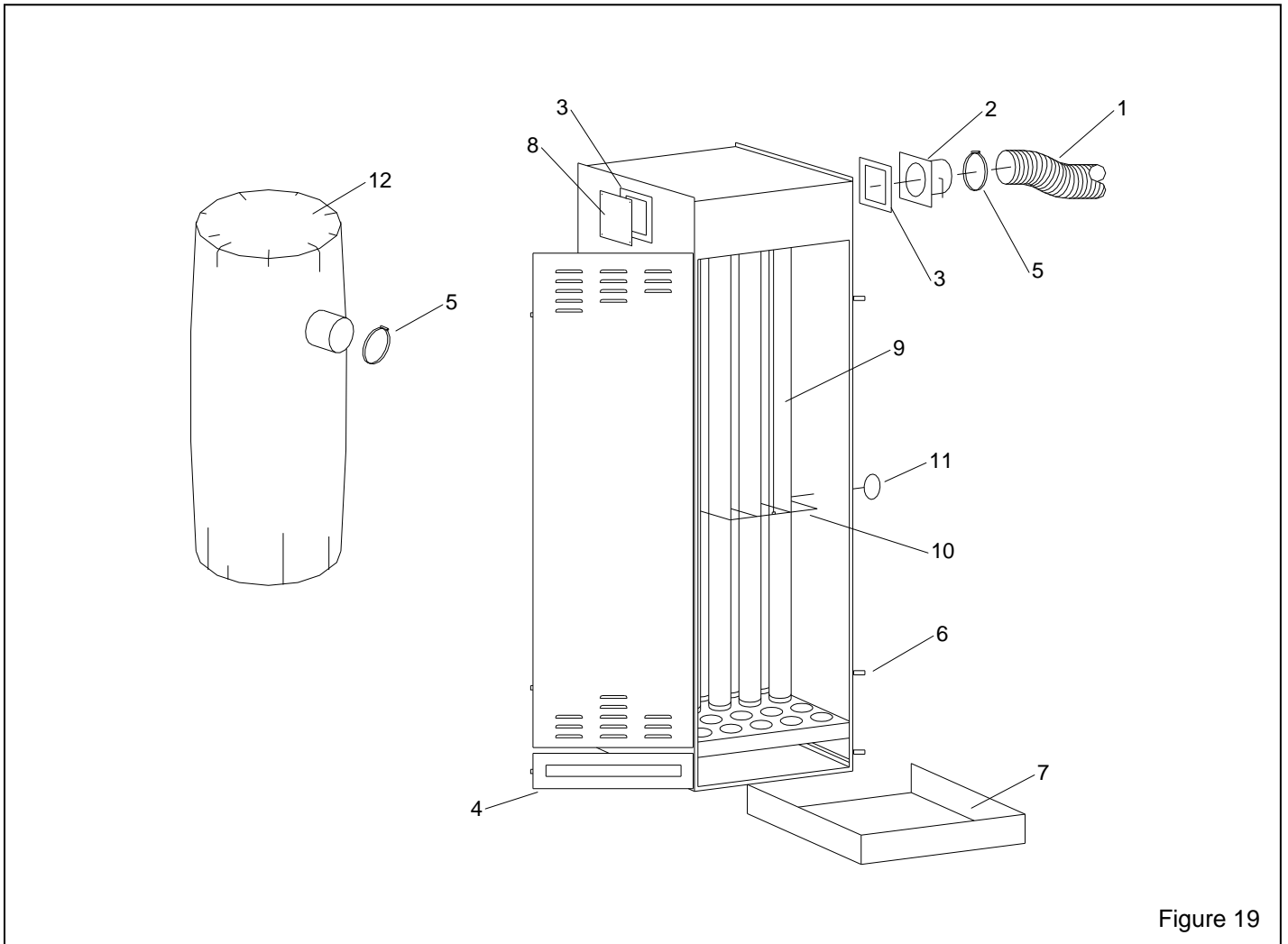

Figure 19