



CLEMCO
The Performance System

TECHNICAL DATA SHEET

Note: For safe, efficient blasting, read and follow the owner's manual and seek training for everyone who will use this equipment.

Purpose

High-performance blast cleaning system removes corrosion, mill scale and coatings from most surfaces. Produces a uniform surface texture, and creates a surface profile to increase bonding for coatings. See related literature for additional applications. Machine holds 2 cubic feet of abrasive for up to 30 minutes of continuous blasting with standard No. 4 nozzle (1/4-inch orifice).

Requirements for Operation

These items are required but not included with this equipment.

- Clean, dry, compressed air of sufficient volume to maintain desired pressure at the nozzle. See Air Consumption Chart in Blast Off 2 booklet.
- Minimum 30 psi needed to operate OSHA-required remote control valves
- Blast suit and work boots
- Abrasive blast media - consult abrasive supplier for appropriate media for your application
- Ambient air pump, capable of delivering 7 to 15 cfm of Grade D breathing air to the Apollo 600 LP. Consult Compressed Gas Association Commodity Specification: G-7.1 (www.cganet.com)

Description of Operation

The operator wears the Apollo 600 LP respirator, which is connected to an optional ambient air pump – such as Clemco's CAP-1. The operator controls blasting from a remote control handle at the nozzle. Pressing the handle starts blasting, releasing it stops blasting. The blast machine contains abrasive and meters it into the compressed air stream.

Description

Field portable, high-production, single-chamber blast machine system, rated at 150 psi, for one operator. Holds 2 cubic feet of blast media. Equipped with Millennium pneumatic pressure-release remote controls. Components listed on next page.



Contractor System Accessories



Operator Safety Equipment

Advantages

- Rated for 150-psi maximum working pressure
- 1-1/2-inch Millennium valve provides unrestricted air flow
- Quantum metering valve maintains smooth, consistent flow; adjustment knob allows precise control of media flow
- 29-inch width fits through standard doorways with moisture separator removed
- Two-wheel integral cart for ease of moving
- Robust handles act as skid for loading machine onto pickup or trailer and protect valves and piping from damage
- Central hookup point for blast hose and remote controls
- High-efficiency moisture separator helps keep abrasive dry
- Weather-resistant storage area holds manuals, paperwork and small parts
- State-of-the-art NIOSH-approved respirator with DLX comfort-fit suspension.

Contractor System 2002 AA with Apollo 600 LP Respirator

Stock No. 21840



2 cu ft Contractor Blast Machine

Approvals and Certifications

Blast machine pressure vessel built to American Society of Mechanical Engineers (ASME) code for 150-psi working pressure. Vessel is hydrostatically tested and National Board certified.

Apollo 600 helmet is NIOSH-approved type-CE air fed respirator and is recognized by OSHA as having an assigned protection factor (APF) against lead dust of 1000 times the permissible exposure limit (PEL).

Remote control system complies with OSHA regulation 1910.244 (b).

NOTE: Prior to use, ensure that Apollo, type-CE, continuous-flow, supplied-air respirator is appropriate for your specific blasting conditions and requirements.

Related Clemco Literature

Description	Stock No.
Contractor Series Catalog	21385
Abrasive Blasting Safety Practices	22090
Blast Off 2	09294
Operator Safety Equipment Product Study	07764
Contractor Blast Machine Owner's Manual	21939

Options and Accessories

Description	Stock No.
Blast machine cover, 16"	02335
Carbon monoxide alarm, CMS-2.....	22894
Heavy cotton/leather blast suit.....S (08920), M (08921), L (08922), XL (08923), XXL (24201), XXXL (24202)	
Seasonal cotton/nylon blast suit.....S (22913), M (22914), L (22915), XL (22916), XXL (22917), XXXL (25022)	
Ambient air pump-single operator, CAP-1	22383
Ambient air pump-four operators, CAP-4.....	22530

Included with Stock No. 21840

Item	Description	Stock No.
1.	2 cu ft contractor blast machine	21490
2.	1-1/2" Millennium valve	21336
3.	Quantum abrasive metering valve.....	22845
4.	50 ft x 1" Supa blast hose, coupled CQPS-1 nylon coupling & NHP-1 nylon nozzle holder	23480
5.	TMP-4 contractor nozzle.....	23520
6.	Blast hose safety cable	15013
7.	1" Air filter/moisture separator w/manual drain	22424
8.	16" recessed blast machine screen	03099
9.	Apollo 600 LP DLX helmet with Comfort-Fit Suspension and Constant Flow Connector	25195
10.	50 ft x 1/2" respirator hose	22510
11.	Leather gloves	02243
12.	Helmet outer lenses, pkg. of 25	04361
	Helmet intermediate lenses, pkg. of 5.....	24943
13.	Nylon ties, (8 provided)	02195
14.	50 ft twinline hose	01951
15.	RLX pneumatic handle	10565
16.	Abrasive trap	02011
17.	Replacement flexible pusher line	23674
(-)	All-weather machine cover (polyethelene bag)	15097
(-)	Quick coupling gaskets, pkg. of 10.....	21584
(-)	Nozzle washers, pkg. of 10	91024
(-)	Abrasive trap screens, 6 ea	02012

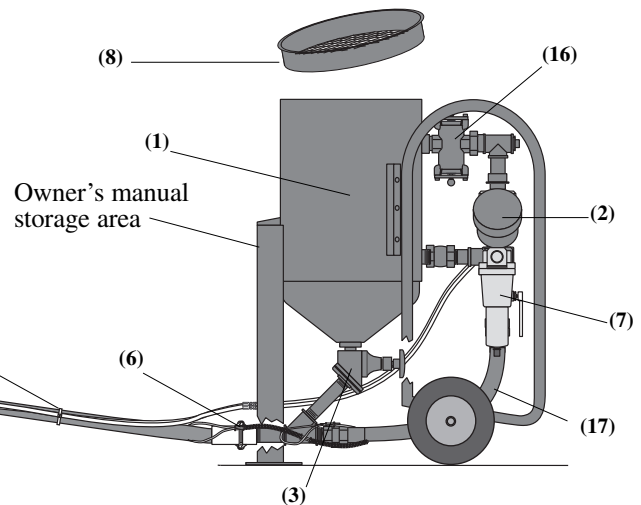
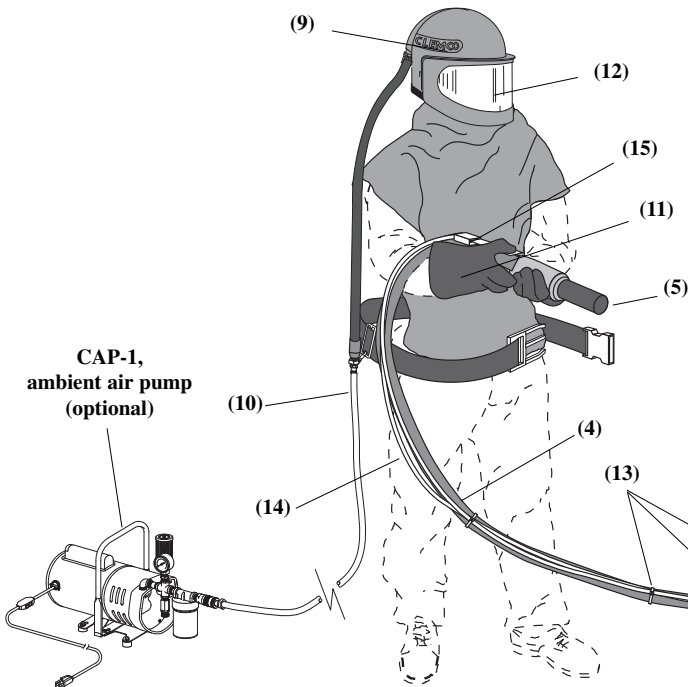

Nominal Dimensions	Unit	Shipping (including skid)
Height (floor to highest point):	43"	55"
Width (outside hub to hub):	29"	35"
Length (hose cplg. to handle):	39"	40"
Machine diameter:	16"	
Net weight:	360 lbs	
Shipping Volume:		44.6 cuft
Shipping Weight:		428 lbs

Packaging

Secured on skid and shrink wrapped

Authorized Distributor:

ISO 9001:2000 certified. Clemco is committed to continuous product improvement. Specifications are subject to change without notice.

© 2009 Clemco Industries Corp. • One Cable Car Drive • Washington, MO 63090 • Phone (636) 239-4300 • Fax (800) 726-7559

Stock No. 22791

www.clemcoindustries.com

Job No. 1195-1295 • Rev. E 06/09