



**CLEMCO**  
The Performance System

## TECHNICAL DATA SHEET

*Note: For safe, efficient blasting, read and follow the owner's manual and seek training for everyone who will use this equipment.*

### Purpose

A blast nozzle accelerates the air and abrasive as the mixture exits the end of the hose. The taper and length of the nozzle's inlet and outlet determine the pattern and velocity of the abrasive exiting the nozzle. The composition of the liner material determines its resistance to wear.

### Requirements for Operation

Nozzles are sized by the diameter of their orifices in 1/16-inch increments. A No. 2 nozzle has a 2/16-inch (1/8-inch) orifice, a No. 3 nozzle has a 3/16-inch orifice, etc. The size of the nozzle orifice determines abrasive and air consumption. Air consumption is measured in cubic feet per minute (cfm) at a given pressure. See the air and abrasive consumption chart on the back of this page.

When choosing a nozzle, consider the amount of available air in cfm, the capacity of the blast machine and the inside diameter of the piping, the blast and air hoses.

If too large a nozzle is used, low blast pressure and rapid wear on the blast hose will occur. If too small a nozzle is used, smooth media flow will be difficult to achieve.

### Description of Operation

The operator attaches the nozzle to the nozzle holder. Threaded nozzles require a holder with matching threads. CJD, CSD and CXD nozzles have 1-1/4-inch threads. TXD nozzles have Contractor threads (50 mm). Flange-style nozzles use a quick-coupling nozzle holder, which couples to most quick couplings. Clemco's nylon quick couplings have built-in lock springs to keep the couplings from becoming uncoupled. If other couplings are used, the operator must install pins to secure the couplings.

## Description

Blast nozzle with venturi shaped tungsten carbide liner and metal jacket. Thread size and entry dimensions vary with nozzle series.



With all related equipment correctly assembled and tested, the operator points the nozzle at the surface to be cleaned and presses the remote control handle to begin blasting. The operator holds the nozzle at the appropriate distance and angle to the surface. The longer the nozzle, the greater the stand-off distance. The normal range for short-venturi nozzles is 12 to 18 inches. For long venturi nozzles it is between 18 and 36 inches. The correct distance will be established for each application.

The operator must check the nozzle and nozzle washer daily for damage or wear and replace as necessary. The nozzle should be replaced when the orifice wears 1/16-inch beyond its original size.

### Advantages

- Rugged and durable aluminum jacket.
- Tungsten carbide is the most rugged and durable liner material and provides the best value.
- Expected wear-life when blasting with expendable abrasives is approximately 300 hours.
- TXD nozzles with large contractor threads eliminate galling or binding of the threads in the holder
- CXD nozzles provide smooth transition from 1-1/4-inch blast hose to the 1-1/4-inch entry for users who prefer 1-1/4-inch fine thread nozzles.

## Nozzles

### Tungsten Carbide Lined Metal Jacketed

Short Venturi: CJD

Long Venturi: CSD, TXD, SDX, CXD

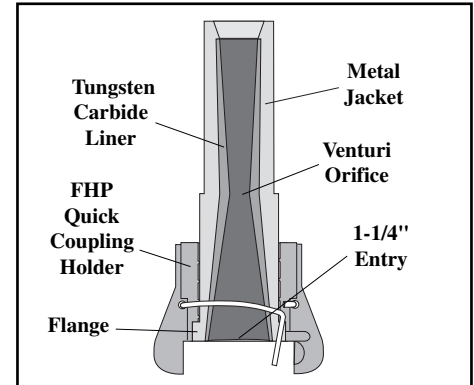

SDX shown

### Replacement Parts

#### Description

#### Stock No.

Nozzle washers shown on reverse.  
Flanged nozzle coupling lock-springs (25) .....21585

Specifications				
Nozzle Model	CJD CSD	CXD	TXD	SDX
Mounting Thread	1-1/4"	1-1/4"	Contractor	*Flanged
Entry Diameter	1"	1-1/4"	1-1/4"	
Liner	Tungsten Carbide			
Liner Style	Venturi			
Jacket Material	Aluminum			
*Flanged nozzle includes quick-coupling nozzle holder				

Authorized Distributor:

ISO 9001-2000 certified. Clemco is committed to continuous product improvement. Specifications are subject to change without notice.

© 2008 Clemco Industries Corp. • One Cable Car Drive • Washington, MO 63090 • Phone (636) 239-4300 • Fax (800) 726-07559

Stock No. 21986

www.clemcoindustries.com

Job No. 1195-1295 • Date of Issue: 06/98, Rev. F; 03/08

Based on abrasives weighing 100 pounds per cubic foot, and compressor horsepower (hp) based on 4 to 4.5 cfm per horsepower.

NOTE: Figures vary depending upon working conditions. The effects of nozzle wear on air consumption must be considered when selecting nozzles and the compressors that support them.

### Compressor Air and Abrasive Consumption

Nozzle Orifice	Pressure at the Nozzle (psi)								Air (in cfm) Abrasive & HP requirements
	50	60	70	80	90	100	125	150	
No. 2 (1/8")	11	13	15	17	18.5	20	25	30	Air (cfm)
	.67	.77	.88	1.01	1.12	1.23	1.52	1.82	Abrasive (cu.ft./hr & Lbs/hr)
	67	77	88	101	112	123	152	182	Compressor hp
No. 3 (3/16")	2.5	3	3.5	4	4.5	5	5.5	6.6	Air (cfm)
	26	30	33	38	41	45	55	66	Abrasive (cu.ft./hr & Lbs/hr)
	1.50	1.71	1.96	2.16	2.38	2.64	3.19	3.83	Compressor hp
No. 4 (1/4")	150	171	196	216	238	264	319	383	Air (cfm)
	6	7	8	9	10	10	12	14	Abrasive (cu.ft./hr & Lbs/hr)
	47	54	61	68	74	81	98	118	Compressor hp
No. 5 (5/16")	2.68	3.12	3.54	4.08	4.48	4.94	6.08	7.30	Air (cfm)
	268	312	354	408	448	494	608	730	Abrasive (cu.ft./hr & Lbs/hr)
	11	12	14	16	17	18	22	26	Compressor hp
No. 6 (3/8")	77	89	101	113	126	137	168	202	Air (cfm)
	4.68	5.34	6.04	6.72	7.40	8.12	9.82	1.178	Abrasive (cu.ft./hr & Lbs/hr)
	468	534	604	672	740	812	982	1,178	Compressor hp
No. 7 (7/16")	18	20	23	26	28	31	37	44	Air (cfm)
	108	126	143	161	173	196	237	284	Abrasive (cu.ft./hr & Lbs/hr)
	6.68	7.64	8.64	9.60	10.52	11.52	13.93	1.672	Compressor hp
No. 8 (1/2")	668	764	864	960	1052	1152	1393	1,672	Air (cfm)
	24	28	32	36	39	44	52	62	Abrasive (cu.ft./hr & Lbs/hr)
	147	170	194	217	240	254	314	377	Compressor hp
No. 8 (1/2")	8.96	10.32	11.76	13.12	14.48	15.84	19.31	2.317	Air (cfm)
	896	1032	1176	1312	1448	1584	1931	2,317	Abrasive (cu.ft./hr & Lbs/hr)
	33	38	44	49	54	57	69	83	Compressor hp
No. 8 (1/2")	195	224	252	280	309	338	409	491	Air (cfm)
	11.60	13.36	15.12	16.80	18.56	20.24	24.59	2.951	Abrasive (cu.ft./hr & Lbs/hr)
	1160	1336	1512	1680	1856	2024	2459	2951	Compressor hp
No. 8 (1/2")	44	50	56	63	69	75	90	108	Air (cfm)
									Abrasive (cu.ft./hr & Lbs/hr)
									Compressor hp

### Nozzle Stock Number, Dimensions, & Weights

		Model No.	Stock No.	Orifice ID	Length	Net Wt	Pkg'd Wt	Holder	Washer
Fine 1-1/4" Thread	1" Entry	CJD-3	01378	3/16"	3-1/8"	.70 lb	1 lb	HEP series or CFP 07716	NW-4
		CJD-4	01379	1/4"	3-1/8"	.70 lb	1 lb		NW-4
		CJD-5	01380	5/16"	3-1/8"	.70 lb	1 lb		NW-4
		CJD-6	01381	3/8"	3-1/8"	.80 lb	1 lb		NW-4
		CJD-7	01382	7/16"	3-1/8"	.80 lb	1 lb		NW-4
		CJD-8	01383	1/2"	3-1/8"	.90 lb	1 lb		NW-4
Fine 1-1/4" Thread	1" Entry	CSD-3	01384	3/16"	4-1/4"	1.1 lb	1.5 lb	HEP series or CFP 07716	NW-4
		CSD-4	01385	1/4"	5-3/8"	1.3 lb	1.5 lb		NW-4
		CSD-5	01386	5/16"	5-3/4"	1.3 lb	1.5 lb		NW-4
		CSD-6	01387	3/8"	6-3/4"	1.6 lb	2 lb		NW-4
		CSD-7	01388	7/16"	8"	2 lb	2 lb		NW-4
		CSD-8	01389	1/2"	9"	2.4 lb	2.5		NW-4
Fine 1-1/4" Thread	1-1/4" Entry	CXD-6	23460	3/8"	6-3/4"	1.6 lb	2 lb	HEP series or CFP 07716	NW-5
		CXD-7	23461	7/16"	8"	2 lb	2 lb		NW-5
		CXD-8	23462	1/2"	9"	2.5 lb	2.5 lb		NW-5
Contractor Thread	1-1/4" Entry	TXD-6	99147	3/8"	6-3/4"	1.9 lb	2 lb	NHP 2 or 3, CFPM 07719	NW-32
		TXD-7	99148	7/16"	8"	2 lb	2.5 lb		NW-32
		TXD-8	99149	1/2"	9-9/16"	2 lb	2.5 lb		NW-32
Flanged	1-1/4" Entry	SDX-6	01394	3/8"	6-3/4"	2.2 lb	3 lb	FHP incl.w/ nozzle	Cplg gskt serves as nozzle washer
		SDX-7	01395	7/16"	8-3/4"	2.2 lb	3 lb		
		SDX-8	01396	1/2"	9-3/16"	2.4 lb	3 lb		
		SDX-10	01397	5/8"	9-3/16"	2.8 lb	3.5 lb		
		SDX-12	01398	3/4"	9"	2.9 lb	3.5 lb		