



CLEMCO
The Performance
System

TECHNICAL DATA SHEET

Note: For safe, efficient blasting, read and follow the owner's manual and seek training for everyone who will use this equipment.

Purpose

High-performance blast cleaning system removes corrosion, mill scale, and coatings from most surfaces. Produces a uniform surface texture, and creates a surface profile to increase bonding for coatings. See related literature for additional applications. Machine holds 2 cubic feet of abrasive for up to 30 minutes of continuous blasting at 100 psi with standard No. 4 nozzle (1/4-inch orifice).

Requirements for Operation

These items are required but not included with this equipment.

- Clean, dry, compressed air of sufficient volume to maintain desired pressure at the nozzle. See Air Consumption Chart in Blast Off 2 booklet.
- Maximum working pressure 150 psi
- Minimum pressure 30 psi needed to operate OSHA-required remote control valves
- NIOSH-approved supplied-air respirator
- Grade D breathing-air supply as defined by the Compressed Gas Association Commodity Specification: G-7.1 (www.cganet.com)
- Abrasive blast media - consult abrasive supplier for appropriate media for your application
- Blast suit and work boots

Description of Operation

The operator controls blasting from a remote control handle at the nozzle. Pressing the handle starts blasting, releasing it stops blasting. The blast machine contains abrasive and meters it into the compressed air stream.

Description

Field portable, high-production, single-chamber blast machine, rated at 150 psi, (for one operator). Holds 2 cubic feet of blast media. Equipped with Millennium pneumatic remote controls and Quantum manual metering valve.

2 Cu Ft Contractor Blast Machine

Stock No. 21490



Advantages

- Rated for 150-psi maximum working pressure
- 1 1/2-inch Millennium valve provides unrestricted air flow
- Quantum metering valve maintains smooth, consistent flow, adjustment knob allows precise control of media flow
- 29-inch width fits through standard doorways
- Two-wheel integral cart for ease of moving
- Robust handles act as skid for loading machine into pickup or trailer and protect valves and piping from damage.
- Central hookup point for blast hose and remote controls
- Weather-resistant storage area holds manuals, paperwork and small parts

Approvals and Certifications

Blast machine pressure vessel built to American Society of Mechanical Engineers (ASME) code for 150-psi working pressure. Vessel is hydrostatically tested and National Board certified.

Remote control system complies with OSHA regulation 1910.244 (b).

Related Clemco Literature

| Description | Stock No. |
|---|-----------|
| Contractor Series Catalog | 21385 |
| Abrasive Blasting Safety Practices | 22090 |
| Blast Off 2 | 09294 |
| Contractor Blast Machine Owner's Manual | 21939 |

Options & Accessories

| Description | Stock No. |
|---|-----------|
| Blast machine cover, 16" | 02335 |
| Blast machine screen, 16" | 03099 |
| Supa blast hose, 1" x 50 ft, coupled w/NHP-1 & CQPS-1 . | 23480 |
| TMP-4 nozzle | 23520 |
| 1" air filter/moisture separator w/manual drain | 22424 |
| Blast hose safety cable | 15013 |
| Apollo 60 HP respirator w/cool air tube & 50ft of hose | 10511 |
| CPF-20 air filter w/pressure regulator & gauge | 03578 |
| Carbon monoxide alarm, CMS-2 | 22894 |
| Heavy cotton/leather blast suit..... S (08920), M (08921), L (08922), XL (08923) | |
| Seasonal cotton/nylon blast suit.... M (22914), L (22915), XL (22916), XXL (22917) | |
| Leather gloves | 02243 |

Included with Stock No. 21490

| Item | Description | Stock No. |
|------|--|-----------|
| 1. | 2 cu ft contractor blast machine | 21490 |
| 2. | 1 1/2" Millennium valve | 21336 |
| 3. | Quantum abrasive metering valve | 22845 |
| 4. | Abrasive trap | 02011 |
| (-) | RLX pneumatic handle | 10565 |
| (-) | 50 ft twinline hose | 01951 |

Installation Dimensions

| | |
|--|----------------------------------|
| A-1 - Floor to center of inlet pipe | 24 ³ / ₈ " |
| A-2 - Floor to center of hose coupling | 3 ¹ / ₄ " |
| A-3 - Width - outside handles | 19 ¹ / ₄ " |

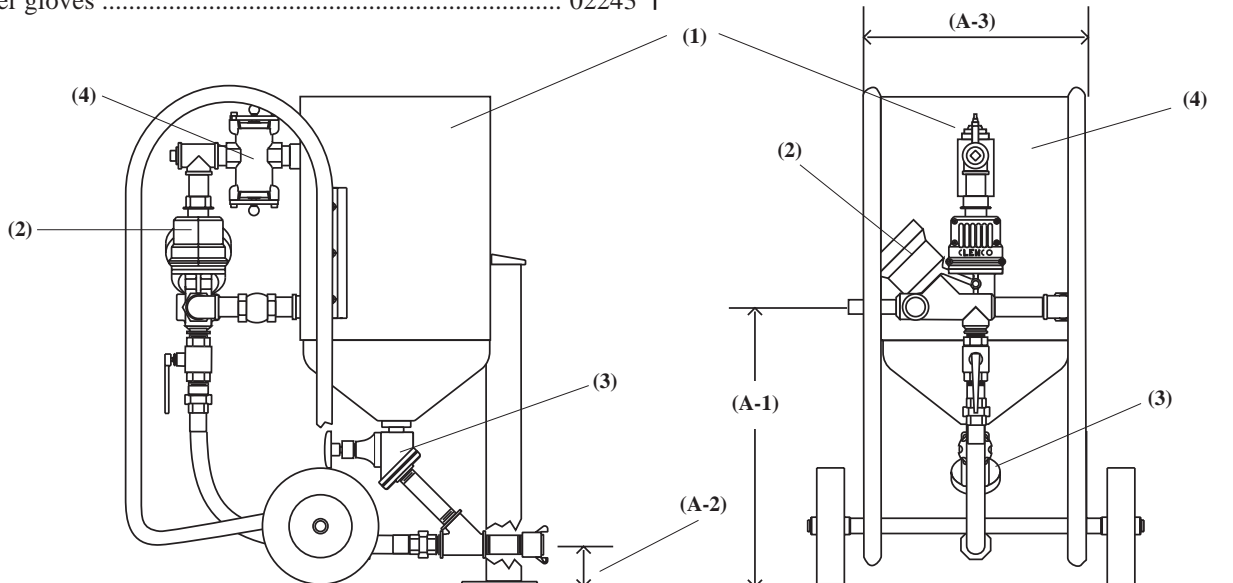

| Nominal Dimensions | Unit | Shipping (including skid) |
|----------------------------------|----------------------------------|---------------------------|
| Height (floor to highest point): | 44" | 49" |
| Width (outside hub to hub): | 28 ³ / ₄ " | 35" |
| Length (hose cplg. to handle): | 39" | 40" |
| Machine diameter: | 16" | |
| Net weight: | 258 lb | |
| Shipping Volume: | | 39.7 cu ft |
| Shipping Weight: | | 326 lb |

Packaging

Secured on skid and shrink wrapped

Color

Champagne

Authorized Distributor:

ISO 9001-2000 certified. Clemco is committed to continuous product improvement. Specifications are subject to change without notice.

© 2004 Clemco Industries Corp. • One Cable Car Drive • Washington, MO 63090 • Phone (636) 239-4300 • Fax (636) 239-0788

Stock No. 21952

www.clemcoindustries.com

Job No. 1195-1295 • Date of Issue: 06/98 Rev. B: 08/04