



**CLEMCO**  
The Performance  
System

## TECHNICAL DATA SHEET

*Note: For safe, efficient blasting, read and follow the owner's manual and seek training for everyone who will use this equipment.*

### Purpose

High-performance blast cleaning system removes corrosion, mill scale, and coatings from most surfaces. Produces a uniform surface texture, and creates a surface profile to increase bonding for coatings. See related literature for additional applications. Machine holds 4 cubic feet of abrasive for up to 30 minutes of continuous blasting at 100 psi with standard No. 5 nozzle (5/16-inch orifice).

### Requirements for Operation

These items are required but not included with this equipment.

- Clean, dry, compressed air of sufficient volume to maintain desired pressure at the nozzle. See Air Consumption Chart in Blast Off 2 booklet.
- Minimum 30 psi needed to operate OSHA-required remote control valves
- Blast suit and work boots
- Abrasive blast media - consult abrasive supplier for appropriate media for your application
- Compressed air source capable of delivering 20 cfm (at 90 to 100 psi) of Grade D breathing-air as defined by the Compressed Gas Association Commodity Specification: G-7.1 ([www.cganet.com](http://www.cganet.com))

### Description of Operation

The operator controls blasting from a remote control handle at the nozzle. Pressing the handle starts blasting, releasing it stops blasting. The blast machine contains abrasive and meters it into the compressed air stream.

## Description

Field portable, high-production, single-chamber blast machine system, rated at 150 psi, (for one operator). Holds 4 cubic feet of blast media. Equipped with Millennium pneumatic remote controls. Components listed on next page.



Contractor System Accessories



Operator Safety Equipment

### Advantages

- Rated for 150-psi maximum working pressure
- 1-1/2-inch Millennium valve provides unrestricted air flow
- Quantum metering valve maintains smooth, consistent flow; adjustment knob allows precise control of media flow
- 1-1/4-inch piping allows up to 50 percent increase in air flow, when compared to 1-inch piping
- 29-inch width fits through standard doorways with moisture separator removed
- CPF-20 breathing air filter, installed
- Four-wheel integral cart for ease of moving
- Robust handles act as skid for loading machine into pickup or trailer and protect valves and piping from damage
- Central hookup point for blast hose and remote controls
- High-efficiency moisture separator helps keep abrasive dry
- Weather-resistant storage area holds manuals, paperwork and small parts
- State-of-the-art NIOSH-approved respirator with DLX comfort-fit suspension.

## Contractor System 2004 CA with Apollo 600 HP Respirator

Stock No. 21548



4 cu ft Contractor Blast Machine with CPF-20 Air Filter Installed

### Approvals and Certifications

Blast machine pressure vessel built to American Society of Mechanical Engineers (ASME) code for 150-psi working pressure. Vessel is hydrostatically tested and National Board certified.

Apollo 600 helmet is NIOSH-approved type-CE air fed respirator and is recognized by OSHA as having an assigned protection factor (APF) against lead dust of 1000 times the permissible exposure limit (PEL).

Remote control system complies with OSHA regulation 1910.244 (b).

*NOTE: Prior to use, ensure that Apollo, type-CE, continuous-flow, supplied-air respirator is appropriate for your specific blasting conditions and requirements.*

## Related Clemco Literature

Description	Stock No.
Contractor Series Catalog .....	21385
Abrasive Blasting Safety Practices .....	22090
Blast Off 2 .....	09294
Operator Safety Equipment Product Study .....	07764
Blast Suits & Gloves Technical Data Sheet.....	21969
Contractor Blast Machine Owner's Manual .....	21941
CPF Filter Owner's Manual.....	04143

## Options and Accessories

Carbon monoxide alarm, CMS-2.....	22894
Blast machine cover, 20" .....	20358
Heavy cotton/leather blast suit .....S (08920), M (08921), L (08922), XL (08923) XXL (24201), XXXL (24202)	
Seasonal cotton/nylon blast suit .....S ( 22913), M (22914), L (22915), XL (22916), XXL (22917), XXXL (25022)	

## Included with Stock No. 21548

Item	Description	Stock No.
1.	4 cu ft contractor blast machine .....	21505
2.	1-1/2" Millennium valve .....	21336
3.	Quantum abrasive metering valve.....	22845
4.	50 ft x 1" Supa blast hose, coupled with CQPS-1 nylon coupling & NHP-1 nylon nozzle holder .....	23480
5.	TMP-5 contractor nozzle.....	23521
6.	Blast hose safety cable .....	15013
7.	1-1/2" Air filter/moisture sep. w/man. drain.....	22363
8.	20" recessed blast machine screen .....	20357
9.	Apollo 600 HP DLX helmet w/Clem-Cool .....	25194
10.	50 ft x 3/8" respirator hose .....	04415
11.	CPF-20 air filter.....	03578
12.	Leather gloves .....	02243
13.	Helmet outer lenses, pkg. of 25 .....	04361
	Helmet intermediate lenses, pkg. of 5.....	24943
14.	Nylon ties, (8 provided) .....	02195
15.	50 ft twinline hose .....	01951
16.	RLX pneumatic handle .....	10565
17.	Abrasive trap .....	02011
18.	Replacement flexible pusher line .....	23675
(-)	All-weather machine cover (polyethelene bag) .....	15143
(-)	Quick coupling gaskets, pkg. of 10.....	21584
(-)	Nozzle washers, pkg. of 10 .....	91024
(-)	Abrasive trap screens, 6 ea.....	02012

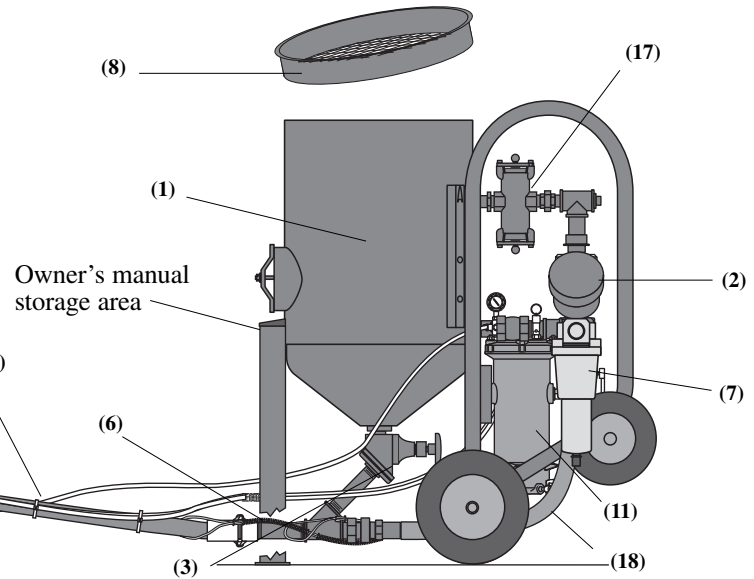
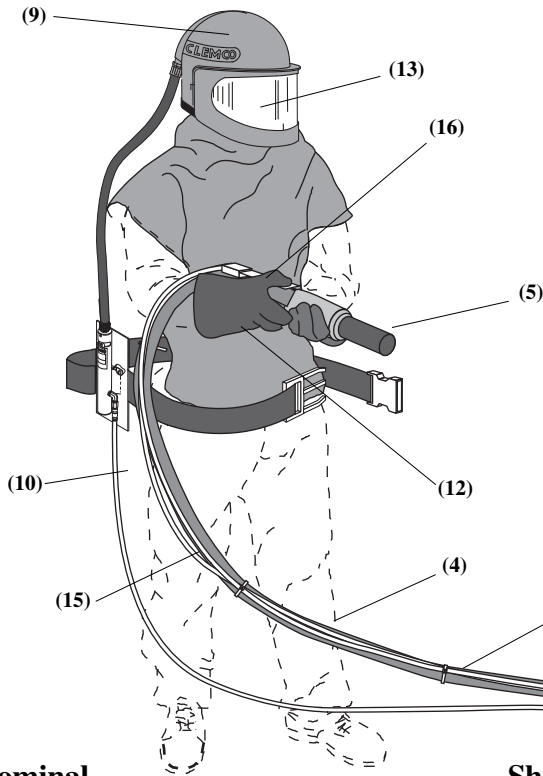

Nominal Dimensions	Unit	Shipping (including skid)
Height (floor to highest point):	49"	60"
Width (outside hub to hub):	29"	35"
Length (hose cplg. to handle):	47-3/4"	48"
Machine diameter:	20"	
Net weight:	494 lbs	
Shipping Volume:		58.3 cuft
Shipping Weight:		566 lbs

## Packaging

Secured on skid and shrink wrapped

Authorized Distributor:

ISO 9001:2000 certified. Clemco is committed to continuous product improvement. Specifications are subject to change without notice.

© 2009 Clemco Industries Corp. • One Cable Car Drive • Washington, MO 63090 • Phone (636) 239-4300 • Fax (800) 726-7559

Stock No. 21947

www.clemcoindustries.com

Job No. 1195-1295 • Rev. D 06/09