

# DCM 161 MINI TUMBLE BLAST CABINET



Clemco Industries Corp. • One Cable Car Drive • Washington, MO 63090  
Phone: (636) 239-4300 • Fax: (636) 239-0788  
Email: [info@clemcoindustries.com](mailto:info@clemcoindustries.com)  
[www.clemcoindustries.com](http://www.clemcoindustries.com)

## NOTICE TO PURCHASERS AND USERS OF OUR PRODUCTS AND THIS INFORMATIONAL MATERIAL

The products described in this material, and the information relating to those products, is intended for knowledgeable, experienced users of abrasive blasting equipment.

No representation is intended or made as to the suitability of the products described herein for any particular purpose of application. No representations are intended or made as to the efficiency, production rate, or the useful life of the products described herein. Any estimate regarding production rates or production finishes are the responsibility of the user and must be derived solely from the user's experience and expertise, and must not be based on information in this material.

The products described in this material may be combined by the user in a variety of ways for purposes determined solely by the user. No representations are intended or made as to the suitability or engineering balance of the combination of products determined by the user in his selection, nor as to the compliance with regulations or standard practice of such combinations of components or products.

It is the responsibility of the knowledgeable, experienced users of the products mentioned in this material to familiarize themselves with the appropriate laws, regulations and safe practices that apply to these products, equipment that is connected to these products, and materials that may be used with these products.

It is the responsibility of the user to insure that proper training of operators has been performed and a safe work environment is provided.

Our company is proud to provide a variety of products to the abrasive blasting industry, and we have confidence that the professionals in our industry will utilize their knowledge and expertise in the safe efficient use of these products.

## OWNER'S MANUAL

## 1.0 INTRODUCTION

### 1.1 Scope of Manual

1.1.1 These instructions cover set-up, operation, maintenance, troubleshooting, optional accessories, and replacement parts for The DCM-161 Mini tumble blast cabinet.

1.1.2 These instructions also contain important information required for safe operation of the cabinet. Before using this equipment, all personnel associated with the blast cabinet operation must read this entire manual, and all accessory manuals to become familiar with the operation, parts, and terminology.

### 1.2 Safety Alerts

1.2.1 Clemco uses safety alert signal words, based on ANSI Z535.4-1998, to alert the user of a potentially hazardous situation that may be encountered while operating this equipment. ANSI's definitions of the signal words are as follows:



This is the safety alert symbol. It is used to alert the user of this equipment of potential personal injury hazards.

Obey all safety messages that follow this symbol to avoid possible injury or death.

---

## CAUTION

---

Caution used without the safety alert symbol indicates a potentially hazardous situation which, if not avoided, may result in property damage.

---



---

## CAUTION

---

Caution indicates a potentially hazardous situation which, if not avoided, may result in minor or moderate injury.

---



---

## WARNING

---

Warning indicates a potentially hazardous situation which, if not avoided, could result in death or serious injury.

---

## DANGER

Danger indicates an imminently hazardous situation which, if not avoided, will result in death or serious injury.

---

### 1.3 General Description

1.3.1 The DCM-161 tumble cabinet blasts small batches of parts, using a fixed nozzle and rotating barrel. See Figure 1 for arrangement and call outs of primary components.

1.3.2 The maximum capacity of the barrel is 25 lbs.

1.3.3 The cabinet requires approximately 17 cfm of compressed air at a maximum of 60 psi.

### 1.4 Theory of Operation

1.4.1 When parts are loaded into the barrel, the air supply and exhaustor are turned "on", and the cabinet door is closed, the cabinet is ready for operation by setting the timer located in the control box atop the cabinet enclosure. Starting the timer causes air to flow through the fixed blast gun mounted through the cabinet door. Air moving through the gun draws media into the blast gun mixing chamber. The media mixes with the air and is propelled out the nozzle. As the barrel rotates, the parts tumble in the blast stream ensuring that all parts and surfaces are uniformly cleaned. The blast media flows through the perforated drum and into the cabinet hopper for reuse. Dust and fines are drawn through the exhaustor and trapped in the dust bag. Blasting automatically stops when the timed cycle is completed.

### 1.5 Dust Collection

1.5.1 The DCM-161 dust bag is not suitable for use in applications which generate toxic dust from lead coatings, heavy metals or any other toxic materials.

---

## WARNING

---

Prolonged exposure to any dust could result in serious lung disease and death. Short term ingestion of toxic materials, such as lead dust or dust from other heavy metals and corrosives, could cause serious respiratory injury or death. This machine is not to be used in applications which generate dust from lead coatings, heavy metals or any other toxic materials. Identify all materials that are to be removed by blasting.

---

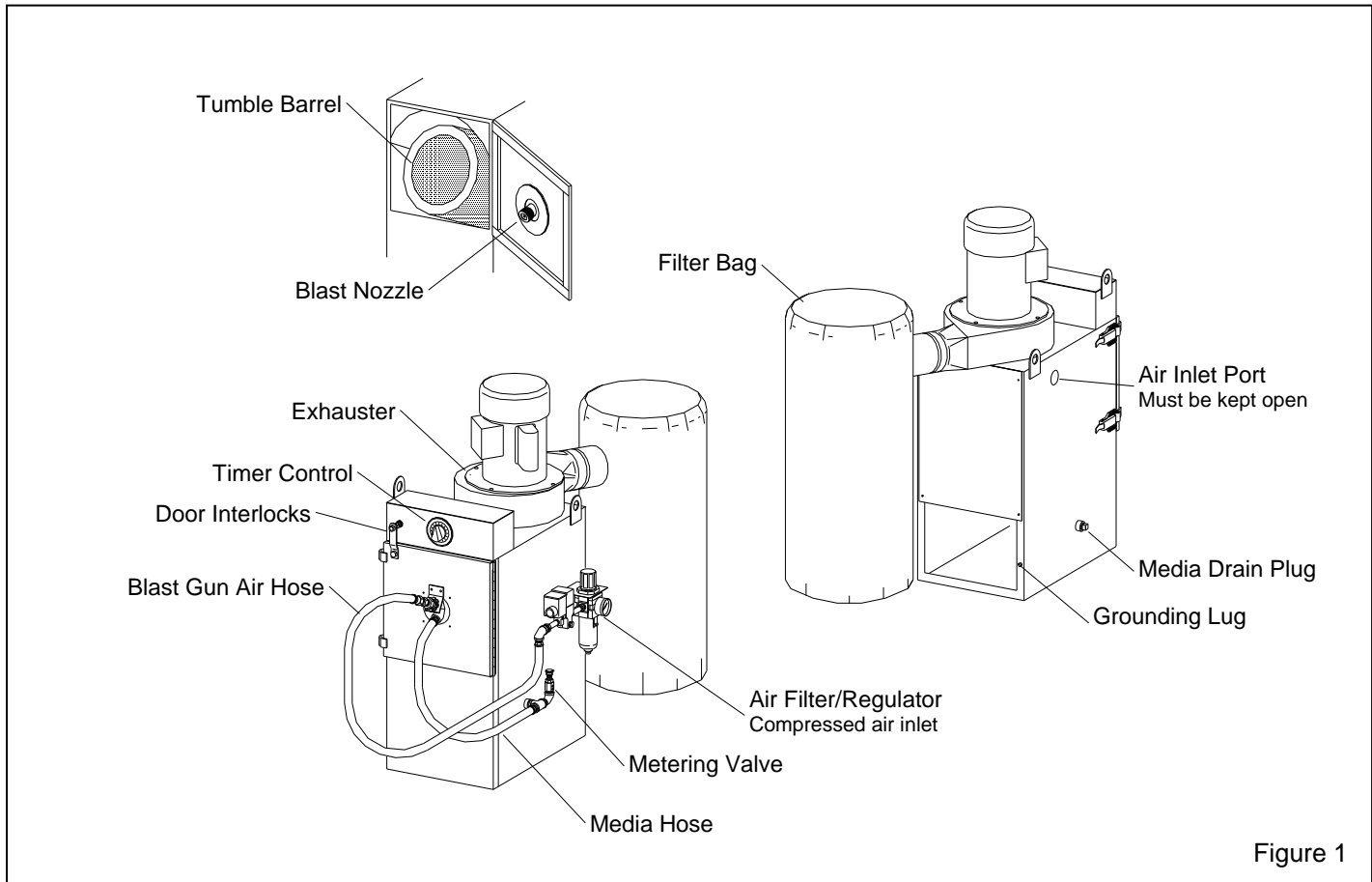

Figure 1

## 1.6 Nozzle Options

**1.6.1** Ventilation requirements limit standard cabinets to No.5 (5/16" orifice) nozzle and No. 4 (1/8" orifice) air jet. Unless otherwise specified at the time of order, cabinets are supplied with a ceramic nozzle. More durable tungsten carbide and boron carbide nozzles are available and are shown under Accessories and Replacement Parts in Sections 7.1 and 7.3. Use boron carbide nozzles when blasting with aggressive media such as those listed in Section 1.8.4.

## 1.7 Tumble Barrel Options

**1.7.1** Standard barrels are perforated with 3/16" holes. An optional barrel with 1/16" holes is available for use with fine abrasive or applications that produce small chips or other byproducts that could plug the blast nozzle. See Section 7.1.

## 1.8 Media

**1.8.1** DCM-161 utilizes most common reusable media 30 mesh to 180 mesh that is specifically manufactured for dry blasting. Media finer than those recommended

may carryover to the dust bag. Media coarser than those recommended may not convey through the media hose. Media life can be extended by mixing the media in the hopper after each cycle.

**1.8.2 Steel:** Steel grit 50 mesh and finer or shot up to 170 may be used.

**1.8.3 Sand and Slag:** Sand should never be used because of the hazards of using media containing free silica. Slags are not recommended because they rapidly break down.

**1.8.4 Aluminum Oxide, Silicon Carbide, and Garnet:** Aggressive media such as these may be used but consideration should be given to accelerated wear on all parts of the cabinet, barrel, nozzle and hoses, which come in contact with the media. When these media are used extensively, use boron nozzles.

**1.8.5 Glass Bead:** Most beads are treated to ensure free-flow operation even under moderately high humidity conditions. Glass beads subjected to excessive moisture may be reused after thorough drying and breaking up of any clumps.

**1.8.6 Fine-mesh Media:** In most cases media finer than 180 will carryover to the dust bag.

**1.8.7 Lightweight Media:** In most cases plastic media and most agricultural media are not recommended with the tumble cabinet. They are usually too light for suction blast applications, and may bridge in the barrel and hopper.

## 1.9 Compressed Air Requirements

**1.9.1** Compressed air consumption for the cabinet is approximately 17 cfm at 60 psi.

**1.9.2** The filter/regulator at the air inlet connection reduces condensed water from the compressed air. Its use is especially important in areas of high humidity, or when fine-mesh media are used. Moisture causes media to clot and inhibits free flow through the feed assembly. If moisture problems persist, an air dryer may be required.

## 1.10 Electrical Requirements

**1.10.1** The system requires 115-VAC, 1-Ph, 60-Hz, with 15 Amps service. A 2-foot power cord is supplied. No additional wiring is required.

## WARNING

**Do not use electrical adaptors that eliminate the ground prong on 115 volt plugs. Doing so can cause injury from electric shock, and equipment damage.**

## 2.0 INSTALLATION

### 2.1 General Installation Notes

**2.1.1** Place the cabinet in a convenient location where compressed air and electrical service are available. Allow full access to the door and service areas. Leave enough clearance around the dust bag for it to inflate without interference.

### 2.2 Connect Compressed Air Supply Line

**2.2.1** Install an isolation valve at the air source to enable depressurization for service. Connect a 1/2 inch or larger air line from the air source to the air filter/regulator.

## WARNING

**If twist-on type air hose couplings are used, they must be secured by safety pins or wires to prevent accidental disconnection while under pressure. Hose disconnection while under pressure could cause serious injury.**

**2.3** To prevent static electricity build up, attach an external grounded wire from an earth ground to the grounding lug on the rear of the cabinet.

**2.4** Attach the dust bag to the exhauster outlet. Secure using the clamp provided.

**2.5.** Plug the cabinet power cord into a grounded, 115 volt outlet.

## 3.0 OPERATION

### 3.1 Control Functions

**3.1.1. Timer:** Sets duration of the blast cycle and starts the blasting. Blasting automatically stops when the timer times out.

**3.1.2 Door Interlock:** When the door is open, the blast gun is disengaged, preventing blasting.

### 3.2 Media Loading and Unloading

**3.2.1 Media Loading:** With the timer off, add clean dry media, by pouring it through the front door. Maximum media capacity is approximately 1/10 cu. ft. (3 quarts). Do not overfill.

**3.2.2 Media Unloading:** To empty the cabinet of spent media, turn off the exhauster and place an empty container under the media drain plug. Unscrew the plug, and tilt the cabinet as needed for media to flow into the container. If media doesn't flow, it has caked. Open the fill door and stir media until it starts to flow. Replace the plug when empty.

**3.2.3** When changing media type, use a vacuum and thoroughly purge the cabinet of media especially when changing from coarse media to fine, or when changing from hard media to soft.

### 3.3 Loading and Unloading Parts

**3.3.1** Parts must be free of oil, water, grease, or other contaminants that will cause media to clump or contaminate parts.

**3.3.2** Load parts directly into the tumble barrel. Do not overload the barrel; maximum load should not exceed 25 lb., or the bottom edge of the retainer as shown in Figure 2.

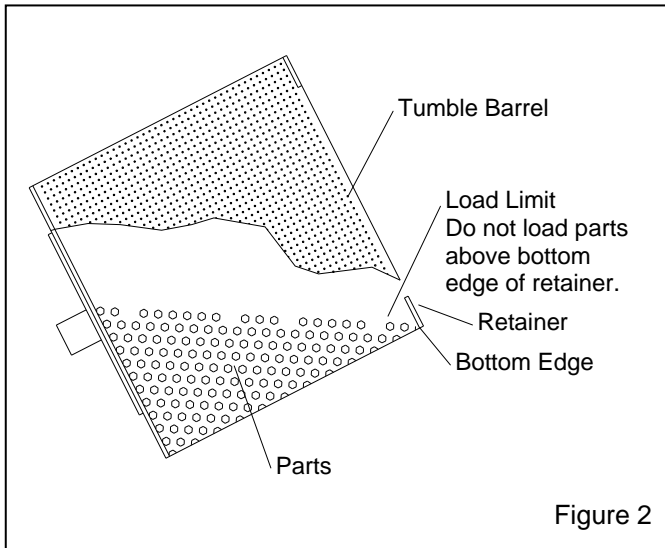

**3.3.3** Close door and latch securely.

### 3.4 Blasting Operation

#### **⚠ WARNING**

- **Keep door closed during blasting.**
- **Stop blasting immediately if dust leaks are detected.**

**3.4.1** Slowly open the air valve on the air supply hose to the cabinet. Check for air leaks on the initial start up, and periodically thereafter.

**3.4.2** Adjust the pressure regulator (filter/regulator) located on the side of the cabinet, to the required blast pressure per Section 4.1.

**3.4.3** Load media and parts. Note load limit in Figure 2.

**3.4.4** Close the cabinet door. Make sure the door is latched securely, or door interlock system will prevent blasting.

**3.4.5** Start the blast cycle by setting the timer for the blast duration. Blasting begins as soon as the timer is set.

#### **⚠ WARNING**

**Shut down the cabinet immediately if dust discharges from the cabinet or filter bag. Make sure that the bag is clamped securely over the exhaust outlet, and that it is not worn or damaged. Prolonged breathing of any dust could result in serious lung disease. Short term ingestion of toxic dust such as lead poses an immediate danger to health. Toxicity and health risk vary with type of media and dust generated by blasting. Identify all material being removed by blasting, and obtain a material safety data sheet for the blast media.**

**3.4.6** Check media flow per Section 4.3.

### 3.5 Stop Blasting

**3.5.1** Blasting, barrel rotation, and the exhauster stop when the timer cycle is complete.

**3.5.2** Open the door only enough to disengage the door interlock, and turn the timer on. Let it run for several seconds to clear airborne dust, then turn the switch off.

**3.5.3** Remove parts and check blast coverage.

**3.5.4** When finished, shut off the air supply valve, drain the air filter.

## 4.0 ADJUSTMENTS

### 4.1 Blasting Pressure

**4.1.1** The filter/regulator enables the user to adjust blasting pressure to suit the application. The maximum recommended pressure is 60 psi. Lower pressure may be used for delicate work. Higher pressure may cause dust or media to escape from the cabinet.

**4.1.2** To adjust, unlock the knob, and turn it clockwise to increase pressure or counter-clockwise to decrease pressure. Pressure will usually drop from closed-line pressure when blasting starts. Once operating pressure is set, lock the knob to maintain the setting.

## 4.2 Timer

**4.2.1** Set the timer for the duration of the blast cycle. Blasting automatically stops when the timer times out. Trial and error will determine the timer setting for the most favorable results. After the part is correctly processed, make a note of the total blast time for future runs of similar parts.

## 4.3 Media/Air Mixture, Figure 3

**4.3.1** Observe media flow through the clear media hose. Media should flow smoothly and evenly through the hose.

**4.3.2** If the air exiting the nozzle pulses or if media does not flow smoothly, the metering valve requires adjusting. To adjust, loosen the locking nut, and adjust the metering screw until the upper holes in the metering stem are closed-off, and the lower holes are fully open, as shown in Figure 3. This adjustment is a starting point.

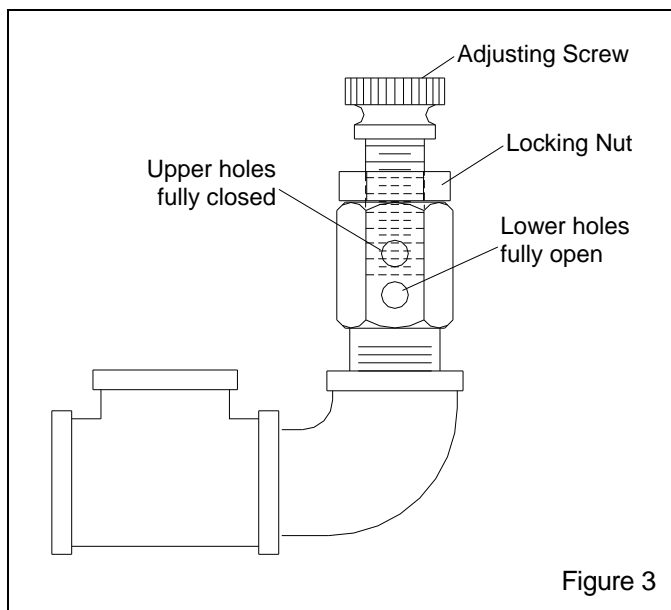

**4.3.3** If pulsation occurs in the media hose, either media is damp and caked, or not enough air is entering the media stream. While blasting, loosen the locking nut and slowly turn the adjusting screw out (counterclockwise when viewed from the top) until the media flows smoothly. Tighten the locking nut to maintain the setting.

**4.3.4** If media flow is too light, decrease air in the mixture by turning the metering screw in (clockwise when viewed from the top) covering more of the holes so less air enters the media hose. Tighten the locking nut to maintain the setting.

## 4.4 Door Interlock, Figure 4

### **⚠ WARNING**

**Never attempt to override the interlock system. Doing so could result in injury from unexpected blasting.**

**4.4.1** The door interlock disables the blasting control circuit when the door is open. To enable blasting, the door interlock switch must be engaged when the door is closed. The interlock is set at the factory and does not usually require field adjustment unless parts are replaced. When adjustment is required, proceed as follows.

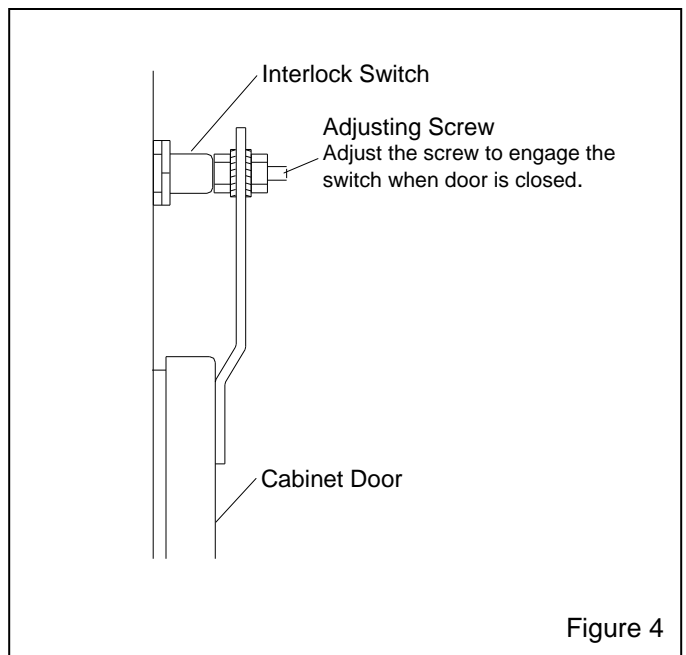

**4.4.2** Close cabinet door.

**4.4.3** Loosen the adjusting screw nut.

**4.4.4** Center the screw on the switch, and turn the adjusting screw in or out as required to engage the switch without applying excessive pressure. Tighten the adjusting screw nut.

**4.4.5** Test the operation with the door open only enough to disengage the interlock switch, and then again with the door closed. The interlock should stop the blasting when the door is opened, and permit blasting when the door is closed.

---

## 5.0 MAINTENANCE

---

### WARNING

---

**This machine is not to be used for applications which generate dust from lead coatings, heavy metals or any other toxic materials. Failure to wear approved respirators and eye protection when servicing dust-laden areas of the cabinet, and when emptying the dust bag could result in serious eye irritation and lung disease. Toxicity and health risk vary with type of media and dust generated by blasting. The respirator must be approved for the type of dust generated. Identify all material being removed by blasting, and obtain a material safety data sheet for the blast media.**

---

NOTE: To avoid unscheduled downtime, establish a weekly inspection schedule. Inspect all parts subjected to media contact, including; the gun, nozzle, media hose, and tumble barrel.

#### 5.1 Dust Bag

**5.1.1** The bag collects dust on its inner surface. A high dust level in the cabinet indicates a dirty bag. Empty as frequently as necessary to maintain good air flow through the cabinet, and before the weight of dust prevents full inflation of the bag. A zipper opening is located in the bottom of the bag for emptying.

**5.1.2** Periodically turn the bag inside out and vacuum the inner surface.

NOTE: Blast media is usually non-toxic, however, materials removed by the process may be toxic. Check with local authorities for disposal restrictions.

#### 5.2 Compressed Air Filter

**5.2.1** The cabinet is equipped with a manual drain air filter/regulator. Drain the filter at least once a day, and more often if water is present. Moist air inhibits the flow of media. If moisture continues to be present, a dryer or after-cooler may be required.

#### 5.3 Nozzle

**5.3.1** Replace the nozzle(s) when its diameter has increased by 1/16", or when suction diminishes noticeably.

**5.3.2** From inside the cabinet door, unscrew the holding nut from the gun end, and pull the nozzle from the gun. Inspect the nozzle o-ring and replace if worn or damaged. Insert a new nozzle, placing the tapered end toward the jet. Screw the holding nut onto the gun.

#### 5.4 Media Hose

**5.4.1** To avoid unscheduled down-time, periodically inspect the media hose for thin spots, by pinching it every 6 to 12 inches.

#### 5.5 Tumble Barrel

**5.5.1** Periodically inspect the barrel for wear. Replace the barrel as soon as it is worn thin.

---

## 6.0 TROUBLESHOOTING

---

### WARNING

---

**To avoid serious injury, observe the following when troubleshooting. Turn off the air, and lock out and tag out the air supply.**

---

#### 6.1 Dust Leaking From the Cabinet Enclosure

**6.1.1** Dirty filter bag. Empty the dust bag regularly. See Section 5.1.

**6.1.2** Damaged door gaskets. Inspect and replace damaged gaskets.

**6.1.3** Blast pressure too high. Maximum blast pressure is 60 psi.

**6.1.4** Paddle wheel worn. Check wheel for wear.

#### 6.2 Abnormally High Media Consumption

**6.2.1** Media may be too fine or worn-out.

**6.2.2** Using friable media that rapidly breaks down.

**6.2.3** Nozzle pressure too high for the media, causing media to break down.

#### 6.3 Reduction in Blast Cleaning Rate

**6.3.1** Low media level reducing media flow. Check and fill if low.

---

**6.3.2** Incorrect metering valve adjustment. Adjust per Section 4.3.

**6.3.3** Reduced air pressure. This may be caused by a malfunctioning regulator, a dirty filter element in the air filter, partially closed air valve, leaking air line, or other air tools in use.

**6.3.4** Blockage in media line or gun. See Section 6.8.

**6.3.5** Worn gun parts such as nozzle or air jet. Inspect and replace all worn parts.

**6.3.6** Worn media hose. Check hose for leaks and soft spots. Replace worn or damaged hose.

**6.3.7** Moist media. Frequent bridges or blockage in the area of the metering valve can be caused by moisture. See Section 6.5.

#### **6.4 Plugged Nozzle**

**6.4.1** Media mixture too rich. Adjust media/air mixture per Section 4.3.

**6.4.2** Remove nozzle and check for blockage from foreign material. If the standard tumble barrel allows large particles to pass and block the nozzle, use the optional barrel with 1/16" diameter holes. Refer to Section 7.1.

#### **6.5 Media Bridging**

**6.5.1** Frequent bridging or blockage in the media metering valve can be caused by damp media. Media becomes damp by blasting parts that are slightly oily, from moisture in the compressed air line, or from absorption.

**6.5.2** To avoid contaminating media from the workpiece, all parts put into the cabinet should be clean and dry. If parts are oily or greasy, degrease and dry them prior to blasting.

**6.5.3** Moist compressed air may be due to a faulty compressor that overheats, or pumps oil or moisture into the air line, too long an air line permitting moisture to condense on the inside, and from high humidity. Drain the air filter and receiver tank regularly. If the problem persists, it may be necessary to change media more often, or install an aftercooler or air dryer.

**6.5.4** Absorption. Some media tends to absorb moisture from the air, especially fine-mesh media in high humidity areas. Empty the media and store it in an airtight container when cabinet is not in use.

**6.5.5** Using lightweight or low-density media as noted in Section 1.8.7.

#### **6.6 Neither Media Nor Air Comes Out the Nozzle When the Blast Cycle is Engaged.**

**6.6.1** Door interlocks not engaging. Check adjustment per Section 4.4.

**6.6.2** Pressure regulator may be turned down or off. Check pressure on pilot regulator.

**6.6.3** Make sure that the air compressor is on and air supply valves are open.

#### **6.7 Blockage in Media Hose**

**6.7.1** Media obstruction. This is usually caused when the media mixture is too rich. Adjust media/air mixture per Section 4.3.

**6.7.2** Wet or damp media. See Section 6.5.

#### **6.8 Media Surge**

**6.8.1** Heavy media flow. Adjust per Section 4.3.

#### **6.9 Poor Suction in Media Hose**

**6.9.1** Nozzle is worn. Replace if worn 1/16" or more.

**6.9.2** Blockage in media hose or nozzle. See Sec. 6.4.

#### **6.10 Blow-Back Through Media Hose**

**6.10.1** Blockage in nozzle. Remove the nozzle and check blockage.

**6.10.2** Air jet washer (Fig. 6 item 5) not tightly sealed against air jet. Tighten the bushing into the gun body.

#### **6.11 Static Shocks**

**6.11.1** Cabinet not grounded. Abrasive blasting generates static electricity. The cabinet must be grounded to prevent static buildup. See Section 2.3.

#### **6.12 Dust Leaking From Dust Bag**

**6.12.1** Check for damaged or loose fitting dust bag.

---

7.0 ACCESSORIES AND REPLACEMENT PARTS

7.1 Optional Accessories

Tumble barrel w/ 1/16" holes .....	18254
Lock pins (pkg. of 25) for twist-on hose couplings ..	11203
Nozzles	
boron carbide, No. 5 .....	11935
tungsten carbide, No. 5 .....	13118

7.2 Cabinet and barrel Assembly, Figure 5

Item	Description	Stock No.
1.	Gasket, door, 7/16" x 1" adhesive backed 4-feet required .....	00190
2.	Latch, spring .....	12263
3.	Barrel assembly	
	Standard, with 3/16" diameter holes .....	12230
	Optional, with 1/16" diameter holes.....	18254
4.	Motor, 1/2-HP 115-VAC .....	12308
5.	Paddle wheel, 100 cfm .....	12339

6.	Housing, 100 cfm exhauster .....	12269
7.	Gasket, 5/16" x 1" adhesive backed specify feet required .....	00187
8.	Clamp, 4" .....	11577
9.	Dust bag 12" x 28" .....	11500
10.	Switch, push button (door interlock) .....	12119
11.	Timer, 60 min. ....	12180
12.	Shaft, barrel drive w/ roll pin & set screw	
	a) 3-7/8-inch long (prior to April 2011) .....	13677
	b) 5-5/8-inch long (effective April 2011) ....	25732
13.	Grommet, rubber .....	11798
14.	Bearing, 3/4" bore .....	11521
15.	Bracket, drive motor mount	
	a) 2" deep w/4 holes, (prior to April 2011) .	12812
	b) 4" deep w/8 holes (effect. April 2011) ...	25842
16.	Motor, speed reduced .....	11905
	a) 5/16" dia. shaft (prior to April 2011) .....	11905
	b) 3/8" dia. shaft, (effective April 2011) ....	25864
17.	Gasket, gun mount back plate .....	11782
18.	Plate, gun mount back .....	12811
19.	Gasket, 5/32" x 3/4" adhesive backed 1-foot required .....	00192

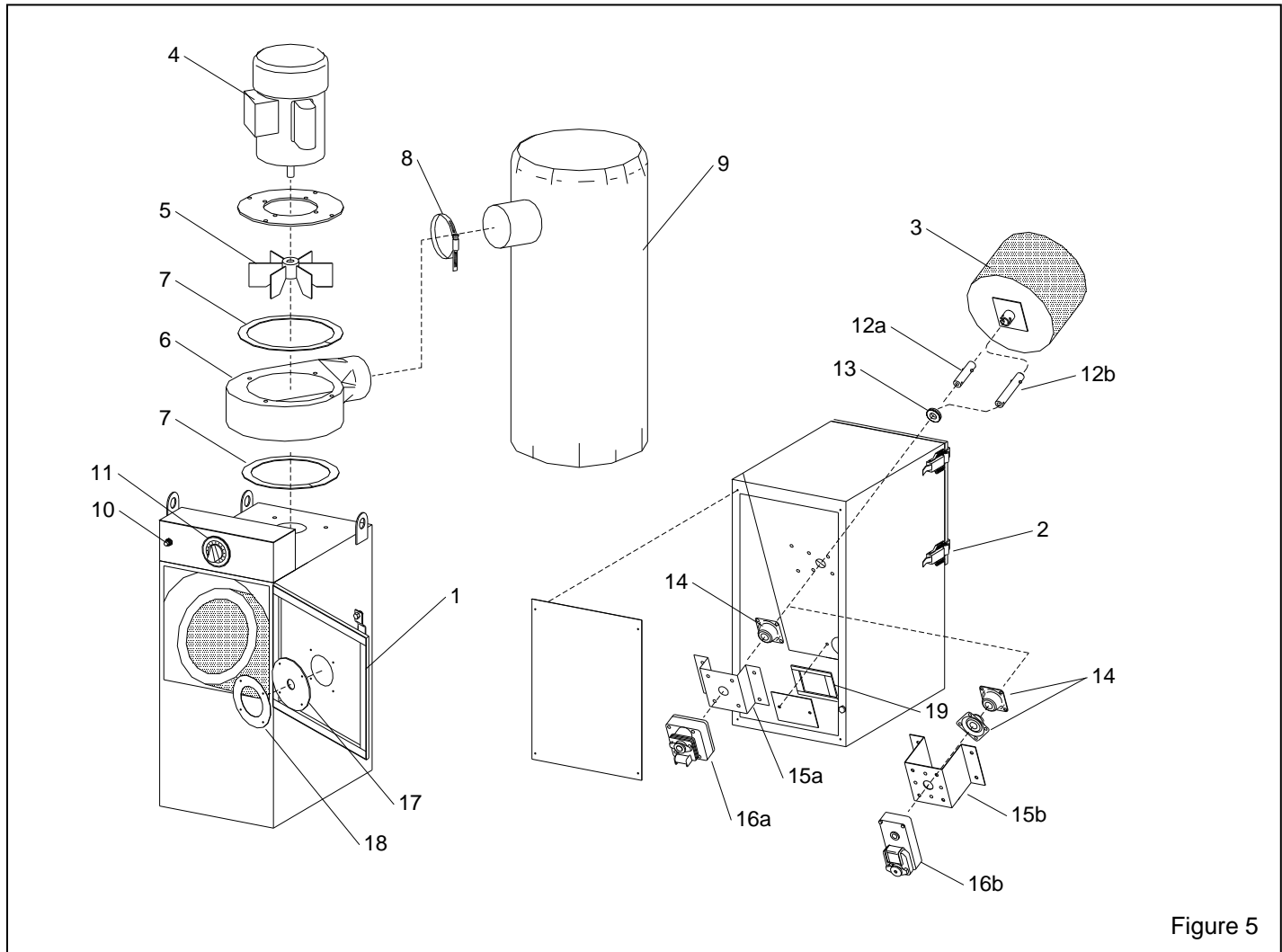

Figure 5

7.3 Gun feed and Plumbing Assembly, Figure 6

Item	Description	Stock No.
(-)	Metering assembly (items 19, 20, & 21) .....	23889
1.	Nut, nozzle holding .....	11914
2.	Body, gun .....	12267
3.	Air jet No. 4 .....	11951
4.	Nozzle	
	Ceramic No. 5, (standard) .....	11930
	tungsten carbide, No. 5 .....	13118
	boron carbide, No. 5 .....	11935
5.	Washer .....	00853

6.	Nut, 3/4" lock .....	12807
7.	Bushing, 3/4" x 3/8" .....	12748
8.	Adaptor, 3/8 male NPT x 1/2" male flare .....	11726
9.	Fitting, hose, 1/2" barb x 1/2" fem. swivel ....	15002
10.	Hose, 1/2" clear media, 3-ft. required .....	12476
11.	Bracket, gun mount .....	12806
12.	Solenoid, 1/4" 3-way .....	12199
13.	Filter/regulator w/gauge, 3/8" NPT .....	11690
14.	Gauge, 1/8" cbm (replacement).....	01908
15.	Fitting, hose, 3/8" NPT x 1/2" barb .....	06369
16.	Hose, 1/2" air, 4-ft. required .....	12472
17.	Muffler, 1/4" bronze .....	03988
18.	Metering valve assembly .....	23889

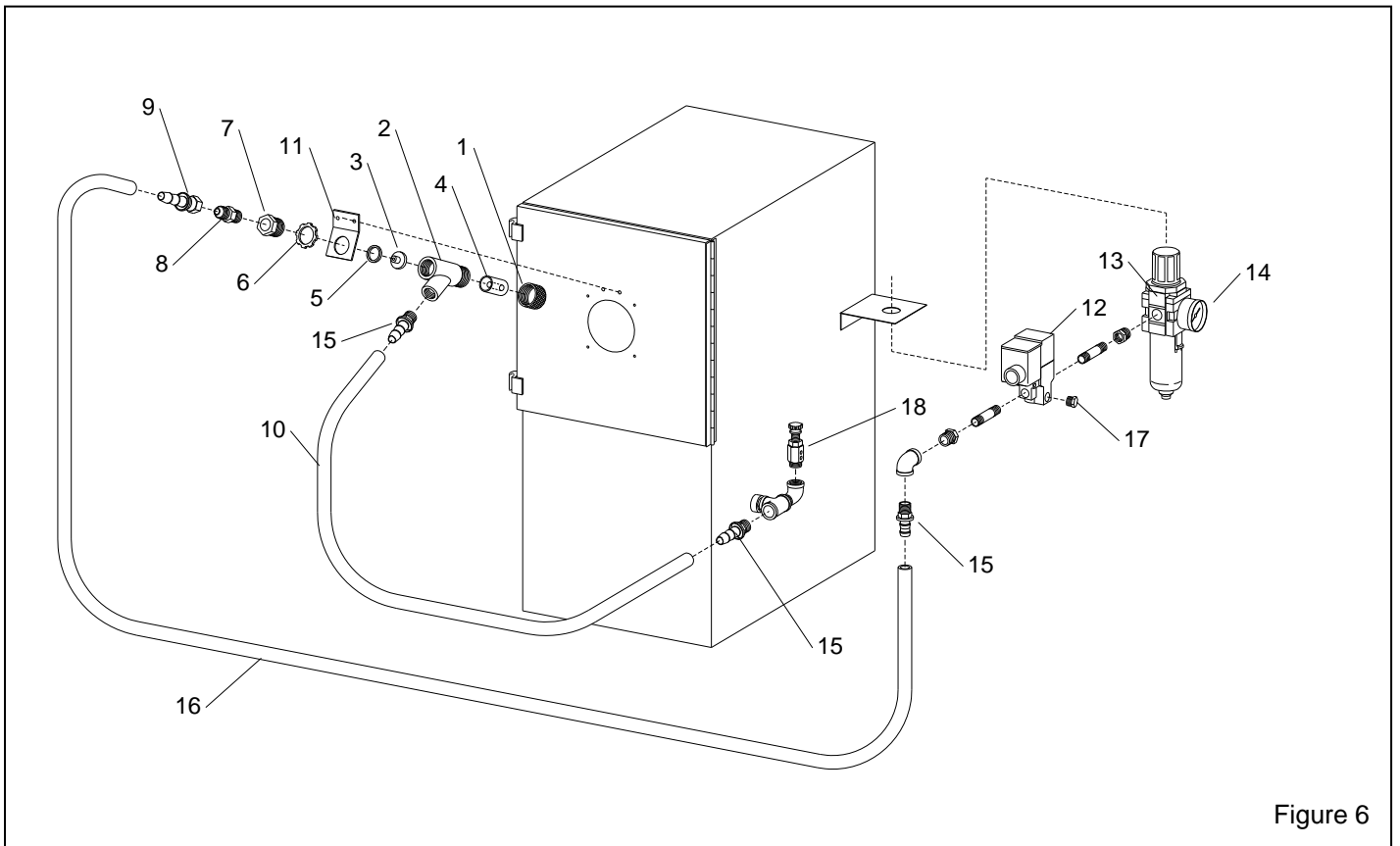

Figure 6